

INSTALLATION INSTRUCTIONS

EQUIPMENT REQUIRED: AVIATION SNIPS (45° ANGLE)

WIRING ACCESS LOCATION: PC3, PC4

HITCH REQUIRES 1/2" PIN AND CLIP

DRILL BITS: 1/8, 3/16, 7/16, 9/16

WRENCHES: (TIGHTEN ALL FASTENERS WITH TORQUE WRENCH) 13mm, 11/16 (DEEP SOCKET)

VEHICLE

SATURN ALL MODELS

HITCH NO.

24620

77014

60839

2000 LB MAX GROSS TRAILER WT
200 LB MAX TONGUE WEIGHT
DO NOT EXCEED TOWING VEHICLE RATINGS

PLASTIC ACCESS PANEL ON SW1
AND SW2 WAGONS TO BE REMOVED

NOTE:

REINFORCEMENT PLATES (1097-041)
AND BLOCKS (1097-007) MUST
BE INSTALLED AS DESCRIBED
BELOW TO INSURE SAFETY.

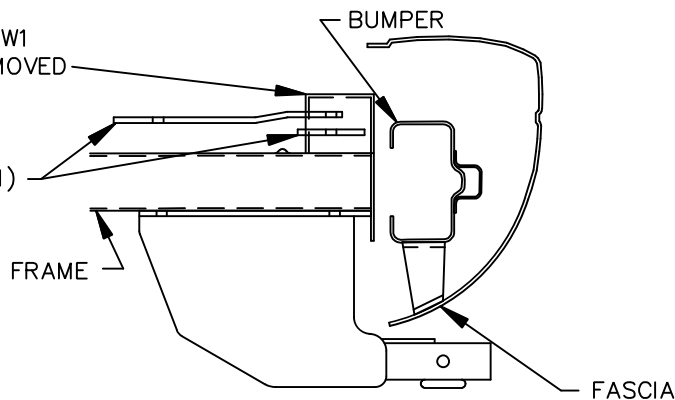

FIGURE 1
HITCH SHOWN IN PROPER LOCATION

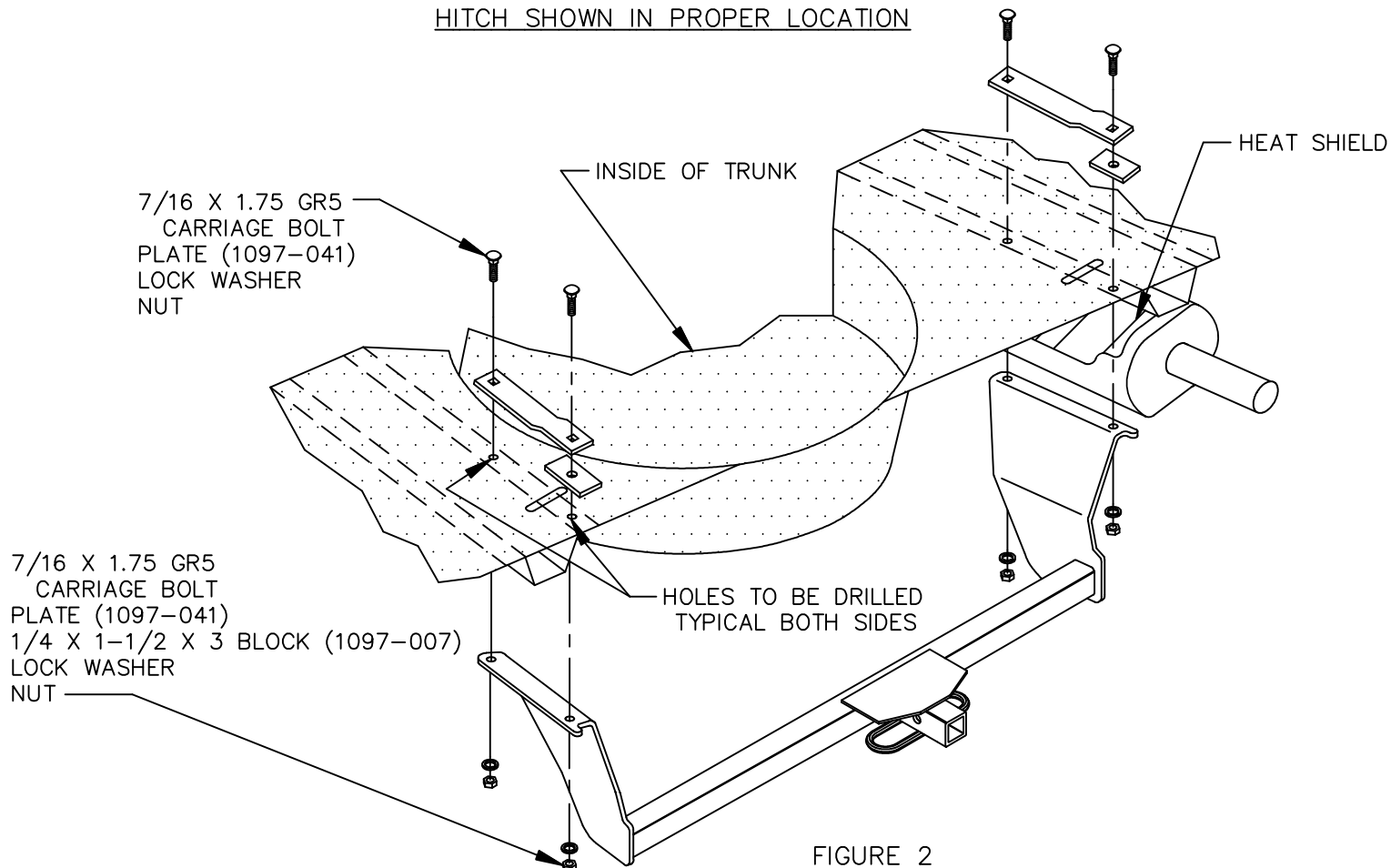

FIGURE 2

THIS PRODUCT COMPLIES WITH SAFETY SPECIFICATIONS AND REQUIREMENTS FOR CONNECTING DEVICES AND TOWING SYSTEMS OF THE STATE OF NEW YORK AND V.E.S.C. REGULATION V-5.

APPROX WEIGHT (LB.)

23

FASTENER KIT

01130-777

NOTE: Check hitch frequently, making sure all fasteners and ball are properly tightened. If hitch is removed, plug all holes in trunk pan or other body panels to prevent entry of water and exhaust fumes. A hitch or ball which has been damaged should be removed and replaced. Observe safety precautions when working beneath a vehicle and wear eye protection. Follow car maker's specs for maximum trailer weight and tongue weight. Do not cut access or attachment holes with a torch.

Cequent Performance Products
Plymouth, Michigan

PRINTED IN MEXICO

INSTALLATION INSTRUCTIONS

VEHICLE

HITCH NO.

SATURN ALL MODELS

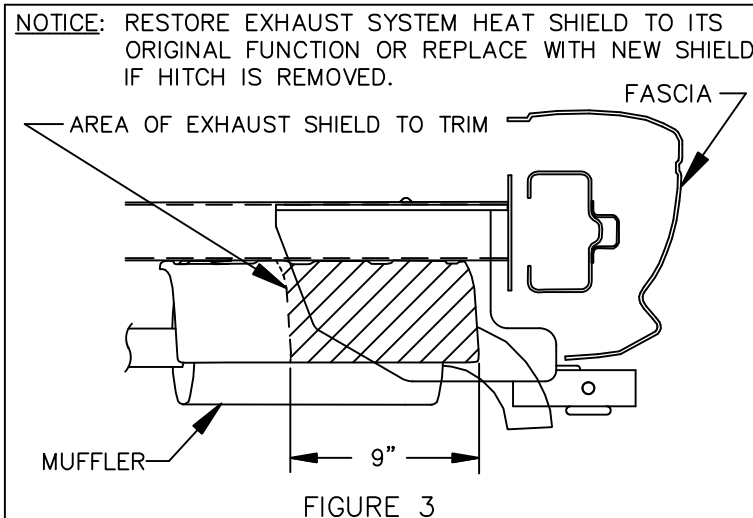
24620
77014
60839

ON SW1 AND SW2 WAGONS ONLY, BEFORE INSTALLING HITCH:

1. REMOVE PLASTIC ACCESS PANEL INSIDE TRUNK FORWARD OF VEHICLE HATCH.

ALL MODELS:

1. REMOVE CARPET AND SPARE TIRE COVER FROM INSIDE TRUNK.
 2. LOWER MUFFLER BY REMOVING 8mm NUT FROM BAND AROUND MUFFLER.
 3. TRIM APPROX. 9" OF EXHAUST SHIELD UP TO THE INBOARD SIDE OF FRAME AS SHOWN IN FIGURE 3.
 4. POSITION HITCH AS FAR REARWARD AS POSSIBLE ON THE INBOARD SIDE OF EACH FRAME, SEE FIGURE 1.
 5. MARK REARWARD HOLE ON PASSENGER'S SIDE FOR DRILLING. REMOVE HITCH FROM VEHICLE. DRILL 1/8" HOLE UP INTO VEHICLE AS MARKED. ENLARGE HOLE TO 9/16".
 6. REMOVE ALL BUT A THIN LAYER OF SEALANT FROM INSIDE TRUNK TO ALLOW REINFORCEMENT PLATES (1097-041) AND BLOCKS (1097-007) TO LAY FLAT IN TRUNK, EACH SIDE.
 7. ON PASSENGER'S SIDE, POSITION REINFORCEMENT PLATE (1097-041) AND BLOCK (1097-007), AS SHOWN IN FIGURE 1, OVER DRILLED HOLE. THE REINFORCEMENT PLATE AND BLOCK SHOULD LINE UP WITH THE EDGE OF THE TRUNK PAN.
 8. MARK FORWARD HOLE ON PASSENGER'S SIDE THROUGH REINFORCEMENT PLATE FOR DRILLING. DRILL 1/8" HOLE DOWN INTO VEHICLE AS MARKED. CHECK HOLE ALIGNMENT UNDER VEHICLE AND ADJUST AS NECESSARY. ENLARGE HOLE TO 9/16".
- NOTE:** BE CAREFUL NOT TO DRILL INTO MUFFLER BELOW.
9. INSTALL REINFORCEMENT PLATE, BLOCK AND 7/16 CARRIAGE BOLTS AS SHOWN IN FIGURE 2. FASTEN WITH LOCK WASHERS AND NUTS.
 - NOTE:** SEAL ALL HOLES DRILLED IN VEHICLE TO PREVENT ENTRY OF EXHAUST FUMES INTO TRUNK.
 10. USING HITCH AS A TEMPLATE, DRILL 7/16" HOLES UP INTO VEHICLE ON DRIVER'S SIDE.
 11. INSTALL REINFORCEMENT PLATE, BLOCK AND 7/16 CARRIAGE BOLTS AS SHOWN IN FIGURE 2. FASTEN WITH LOCK WASHERS AND NUTS. TIGHTEN 7/16 GR5 FASTENERS TO 50 LB.-FT.
 12. RECONNECT MUFFLER. TIGHTEN 8mm CL9.8 FASTENER TO 25 LB.-FT.
 13. REPLACE SPARE TIRE COVER AND CARPET INSIDE TRUNK. (REPLACE PLASTIC ACCESS PANEL ON SW1 & SW2 MODELS.)

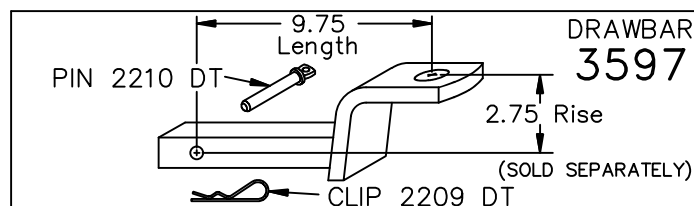

USE ONLY THE DRAWBAR SHOWN FOR CORRECT BUMPER CLEARANCE AND HEIGHT.
DRAWBAR MUST BE USED IN THE RISE POSITION ONLY.

THIS PRODUCT COMPLIES WITH SAFETY SPECIFICATIONS AND REQUIREMENTS FOR CONNECTING DEVICES AND TOWING SYSTEMS OF THE STATE OF NEW YORK AND V.E.S.C. REGULATION V-5.

APPROX WEIGHT (LB.)

23

FASTENER KIT

01130-777

NOTE: Check hitch frequently, making sure all fasteners and ball are properly tightened. If hitch is removed, plug all holes in trunk pan or other body panels to prevent entry of water and exhaust fumes. A hitch or ball which has been damaged should be removed and replaced. Observe safety precautions when working beneath a vehicle and wear eye protection. Follow car maker's specs for maximum trailer weight and tongue weight. Do not cut access or attachment holes with a torch.

Cequent Performance Products
Plymouth, Michigan
PRINTED IN MEXICO