

INSTALLATION INSTRUCTIONS

EQUIPMENT REQUIRED:

WIRING ACCESS LOCATION:

DRILL BITS: 1/2"

HITCH REQUIRES 1/2" PIN AND CLIP.

WRENCHES: (TIGHTEN ALL FASTENERS WITH TORQUE WRENCH) 9/16, 10mm, 13mm, 15mm

VEHICLE
 OLDSMOBILE LSS
 OLDSMOBILE 88
 PONTIAC BONNEVILLE
 (ALL MODELS EXCEPT SSE, SSEi AND SLE)

3500 LB MAX GROSS TRAILER WT
 300 LB MAX TONGUE WEIGHT
 DO NOT EXCEED TOWING VEHICLE RATINGS

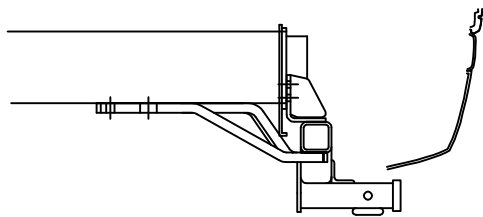

HITCH SHOWN IN PROPER POSITION

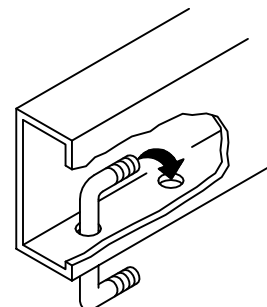

FIG. 2

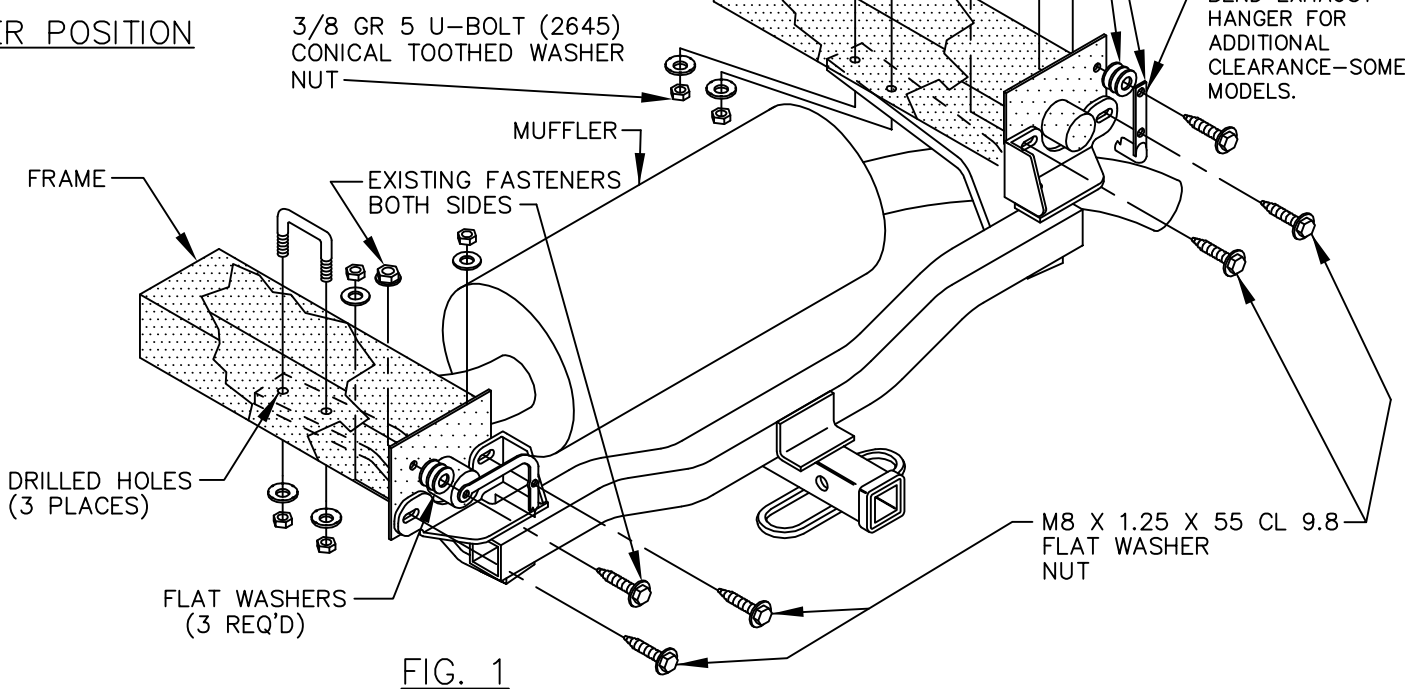

FIG. 1

TIGHTEN U-BOLTS EVENLY WITH HAND TORQUE WRENCH. DO NOT USE IMPACT WRENCH.

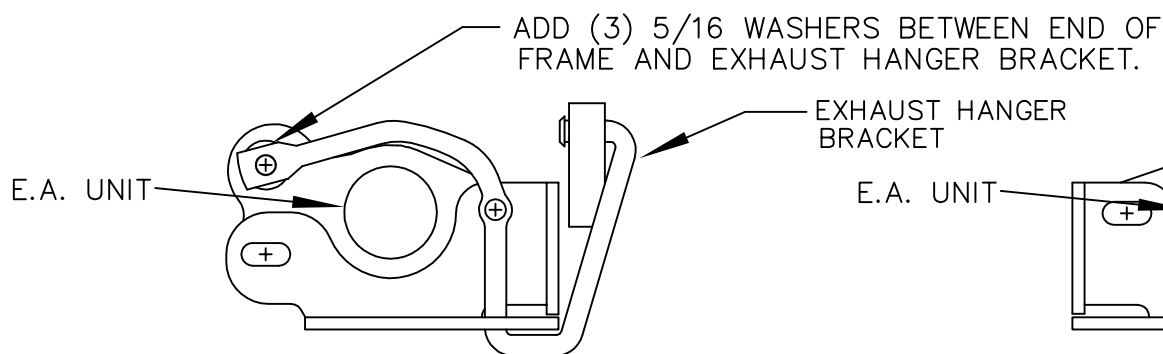

FIG. 3
 DRIVER'S SIDE

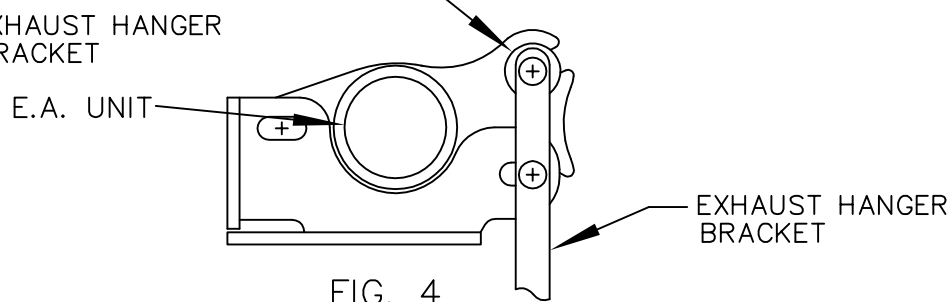
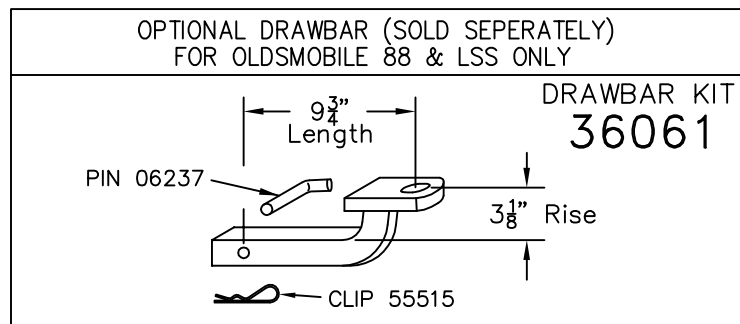
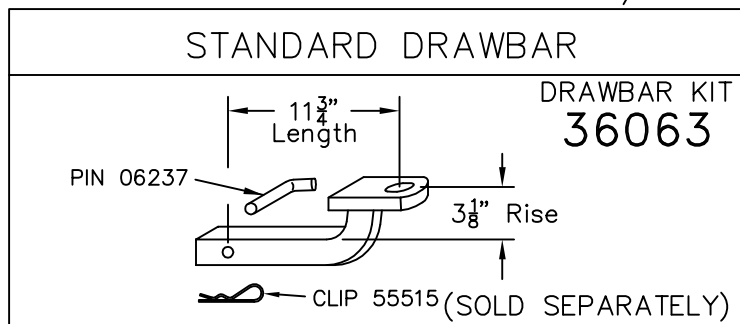

FIG. 4
 PASSENGER SIDE

1. REMOVE INBOARD AND LOWER OUTBOARD ENERGY ABSORBER (E/A) UNIT MOUNTING BOLTS FROM BOTH SIDES OF FRAME. REMOVE THE UPPER OUTBOARD BOLT THAT ATTACHES THE EXHAUST HANGER BRACKET TO END OF THE FRAME ON DRIVER'S AND PASSENGER SIDE.
2. POSITION THE HITCH ON THE VEHICLE AS SHOWN AND LOOSELY INSTALL THE M8 BOLTS PROVIDED. USE THE HITCH SIDE ARMS AS A TEMPLATE TO DRILL FOUR (4) 1/2" HOLES.
 NOTE: THE SIDE ARMS MUST SIT FLAT AGAINST THE VEHICLE FRAME. CHISEL OR DRILL OUT RIVETS HOLDING HEAT SHIELD UNDER SIDE ARMS IF REQUIRED. ALSO, BEND HEAT SHIELD IF NEEDED.
3. LOWER SIDE ARMS AND INSERT THE 3/8 U-BOLTS THROUGH THE FRAME AS SHOWN IN FIG. 2. RAISE SIDE ARMS INTO POSITION AND INSTALL THE 3/8 CONICAL WASHERS AND NUTS ON THE U-BOLTS.
 NOTE: DRIVER'S SIDE EXHAUST HANGER BRACKET MUST BE REATTACHED THROUGH THE OPENING IN THE HITCH UPRIGHT BEFORE REATTACHING SHOULDER BOLT AS SHOWN IN FIG. 3.
 THIS WILL REQUIRE WASHERS TO BE USED AS SPACERS BETWEEN THE BRACKET AND VEHICLE. SEE FIGS. 3 & 4.
4. USE THREE (3) 5/16 FLAT WASHERS PROVIDED TO SHIM SPACE BETWEEN EXHAUST BRACKET AND THE UPPER OUTBOARD ATTACHMENT FOR E/A UNIT ON DRIVER'S AND PASSENGER SIDE. USE EXISTING FASTENERS TO REATTACH EXHAUST HANGER BRACKET, SEE FIG 3 AND 4. DEFORMATION OF SHEET METAL FLANGES ON E/A MOUNTING SURFACES IS PERMISSIBLE WHEN FASTENERS ARE TIGHTENED.
5. SOME MODELS MAY REQUIRE BENDING EXHAUST HANGER ON PASSENGER SIDE FOR REQUIRED CLEARANCE.
 TIGHTEN M8 CL9.8 FASTENERS TO 25 LB.-FT.
 TIGHTEN 3/8 GR5 FASTENERS TO 31 LB.-FT.



USE ONLY THE DRAWBAR SHOWN FOR CORRECT BUMPER CLEARANCE AND HEIGHT. DRAWBAR MUST BE USED IN THE RISE POSITION ONLY.

THIS PRODUCT COMPLIES WITH SAFETY SPECIFICATIONS AND REQUIREMENTS FOR CONNECTING DEVICES AND TOWING SYSTEMS OF THE STATE OF NEW YORK, V.E.S.C. REGULATION V-5 AND SAE J684.

APPROX WEIGHT (LB.)	FASTENER KIT
33	01130-937

NOTE: Check hitch frequently, making sure all fasteners and ball are properly tightened. If hitch is removed, plug all holes in trunk pan or other body panels to prevent entry of water and exhaust fumes. A hitch or ball which has been damaged should be removed and replaced. Observe safety precautions when working beneath a vehicle and wear eye protection. Follow car maker's specs for maximum trailer weight and tongue weight. Do not cut access or attachment holes with a torch.

TOWING PRODUCTS
 Plymouth, Michigan
 PRINTED IN MEXICO