

Installation Instructions

Part Numbers:

ACURA 3.5 RL

36226

(Sold separately)

Drawbar Kit:

36061

Drawbar must be used in the **RISE** position only.

**Do Not Exceed Lower of Towing Vehicle
Manufacturer's Rating or**

3500 LB Max Gross Trailer Weight

300 LB Max Tongue Weight

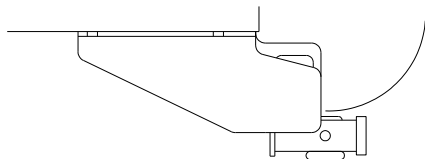

Hitch Shown In Proper Position

Wiring Access Location: PC3

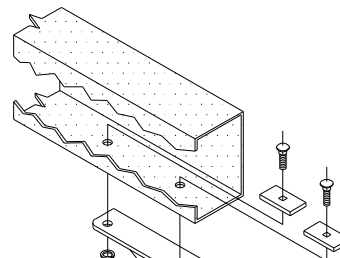

Equipment Required: fish wire (provided)

Fastener Kit: 01130-978

Wrenches: 14mm, 17mm, 7/8"

Drill Bits: 1/2"

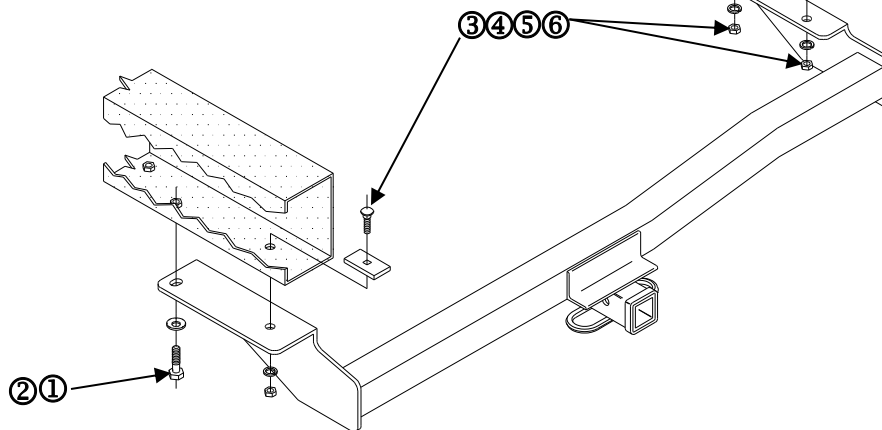

①	Qty. (1)	Bolt – hex head M10 x 1.25 x 30mm	④	Qty. (3)	Block 1/4 x 1 x 3
②	Qty. (1)	Washer – 3/8" conical toothed	⑤	Qty. (3)	Washer - lock
③	Qty. (3)	Bolt – carriage 1/2"-13 x 1-3/4"	⑥	Qty. (3)	Nut 1/2" -13

1. Remove tow hook from drivers side of vehicle frame rail and return to vehicle owner.
2. Lower vehicle exhaust.
3. Center hitch on vehicle frame and install the M10 fasteners (item 1&2) as shown above.
4. Using the hitch as a template, drill three (3) 1/2" holes in frame rails as shown above.
5. Install the remaining fasteners as shown above.
6. Re-attach the exhaust.

Tighten all 1/2" fasteners with torque wrench to 75 Lb.-Ft. (102 n*m)

Tighten all M10 fasteners with torque wrench to 38 Lb.-Ft. (52 n*m)

Note: check hitch frequently, making sure all fasteners and ball are properly tightened. If hitch is removed, plug all holes in trunk pan or other body panels to prevent entry of water and exhaust fumes. A hitch or ball which has been damaged should be removed and replaced. Observe safety precautions when working beneath a vehicle and wear eye protection. Do not cut access or attachment holes with a torch.

This product complies with safety specifications and requirements for connecting devices and towing systems of the state of New York, V.E.S.C. Regulation V-5 and SAE J684.