

INSTALLATION INSTRUCTIONS

VEHICLE

JEEP GRAND CHEROKEE

EQUIPMENT REQUIRED:

WIRING ACCESS LOCATION: SUV3

DRILL BITS:

HITCH REQUIRES 1/2" PIN & CLIP

WRENCHES: (TIGHTEN ALL FASTENERS WITH TORQUE WRENCH) 18mm, 19mm

3500 LB MAX GROSS TRAILER WT
300 LB MAX TONGUE WEIGHT
DO NOT EXCEED TOWING VEHICLE RATINGS

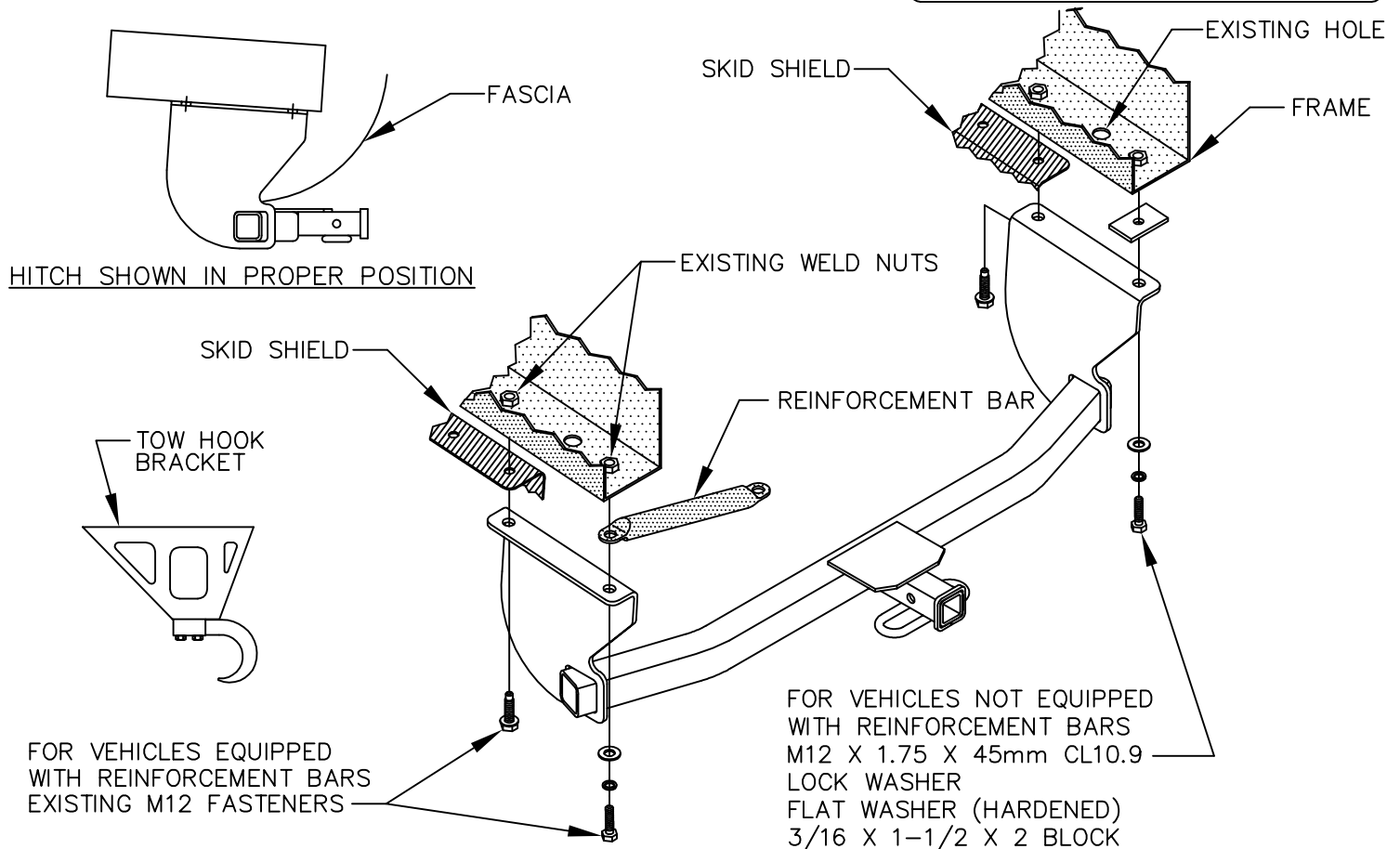

NO DRILLING REQUIRED

1. REMOVE TOW HOOK BRACKET IF PRESENT.
2. REMOVE THE M12 FASTENERS FROM THE FOUR REARMOST VEHICLE FRAME WELDNUTS. THE SKID SHIELD WILL REMAIN IN PLACE.
3. RAISE HITCH INTO POSITION AND INSTALL/RE-INSTALL FASTENERS AS SHOWN ABOVE.
NOTE: USE EXISTING FASTENERS IF VEHICLE IS EQUIPPED WITH REINFORCEMENT BARS.

TIGHTEN ALL M12 CL10.9 FASTENERS TO 75 LB-FT.

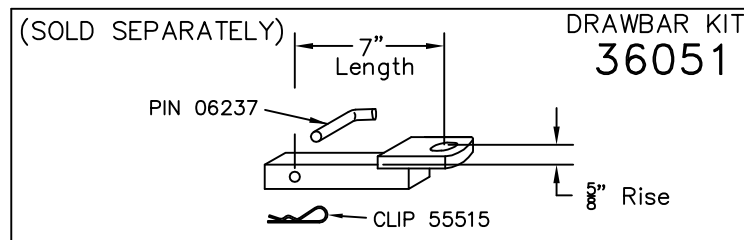

USE ONLY THE DRAWBAR SHOWN FOR CORRECT BUMPER CLEARANCE AND HEIGHT.
DRAWBAR MUST BE USED IN THE RISE POSITION ONLY.

THIS PRODUCT COMPLIES WITH SAFETY SPECIFICATIONS AND REQUIREMENTS FOR CONNECTING DEVICES AND TOWING SYSTEMS OF THE STATE OF NEW YORK, V.E.S.C. REGULATION V-5 AND SAE J684.

APPROX WEIGHT (LB.)	FASTENER KIT
28.8	01131-122

NOTE: Check hitch frequently, making sure all fasteners and ball are properly tightened. If hitch is removed, plug all holes in trunk pan or other body panels to prevent entry of water and exhaust fumes. A hitch or ball which has been damaged should be removed and replaced. Observe safety precautions when working beneath a vehicle and wear eye protection. Follow car maker's specs for maximum trailer weight and tongue weight. Do not cut access or attachment holes with a torch.

TOWING PRODUCTS
Plymouth, Michigan