

Quic'n Easy Assembly Instructions

2001-2009 Chevy 2500/3500 HD Short Bed

Mounting Kit: 47082022

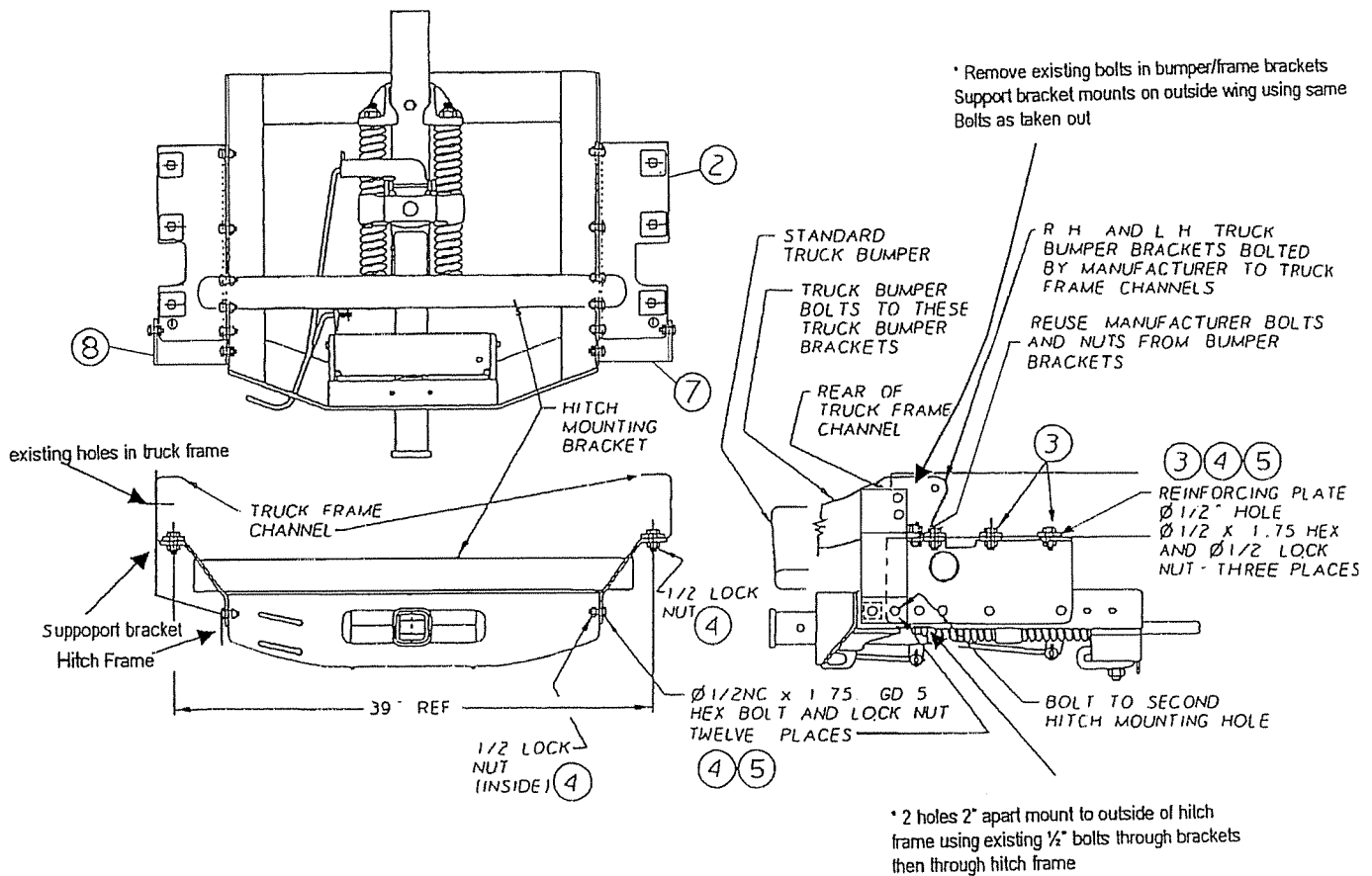

ITEM	PART NUMBER	QTY	DESCRIPTION
1.	47082022	1	Mounting Kit
2.	47077601	1	Bracket Weldment
3.	47077507	8	1/2" Plate Reinforcement
4.	14110801	18	1/2" Nyloc Lock Nut
5.	16008075	18	1/2"-13x1-3/4" Hex Bolt GRD 5
7.	47082022F/P(R)	1	Reinforce Bracket, Right
8.	47082022F/P(L)	1	Reinforce Bracket, Left

Quic'n Easy Assembly Instructions

2001-2009 Chevy 2500/3500 HD Short Bed

Mounting Kit: 47082022

Follow assembly instructions below. Refer to assembly drawings and instructions on previous page.

1. Remove spare tire and tighten tire carrier/tire winch to prevent vibration noise.
NOTE: Do not remove any welded or riveted-fast cross members.
2. Remove (2) vertical M14 truck hex bolts from the truck bumper bracket or hitch at rear of truck. Do not remove welded-on nuts from bumper bracket.
3. If applicable, remove factory hitch receiver. Depending on model, hitch may be attached by bolts and welds. **NOTE: Do not remove any welded or riveted-fast cross members.**
4. Loosely bolt main mounting bracket (#2) onto truck frame. Use supplied 1/2" bolts, nuts, and washer plates (#2, 3, 4) for the forward 3 holes. Place reinforcing plates over holes in truck frame and align with holes in mounting bracket. Snug nuts to hold in place, but do not tighten hardware at this time.
5. Loosely bolt reinforcement brackets (#7, 8) in place with existing bolts from bumper bracket (Refer to drawing above). Use removed M14 bolts from bumper bracket or hitch. For years 2001-2006, the reinforcement brackets need to fit between existing truck bumper bracket and truck frame. Use a screwdriver to leverage the bracket up and slip reinforcement bracket in place. Snug nuts to hold in place, but do not tighten at this time.
6. Install Quic'n Easy frame to hitch mounting brackets. Raise to location to align (10) 1/2"-13 x 1-3/4" bolts (#5) through frame, fastening with lock nuts (#4). For rearmost hole on reinforcement brackets (#7,8) use reinforcement plate (#3) to level distance between hitch and bracket. Refer to bottom-right drawing.
7. **IMPORTANT: Torque to specification**
 - 1/2" diameter grade 5 bolts: 85 ft lbs
 - 9/16" diameter grade 5 bolts (from bumper bracket): 125 ft lbs
8. **IMPORTANT: when complete check all clearances between truck components and Quic'n Easy receiver hitch assembly. A minimum of 2- 1/4" between the spring casting and above obstructions is required to allow proper and safe operation.**
9. Insert red plastic handle covers over slide handle and pin lever handle.