

Installation Instructions

5613200 Gooseneck Flip Ball Hitch

Ford Super Duty - 1999-2010
 F-250 & F-350 Short & Long Bed
 Ford F-450 with factory installed Bed



To simplify the installation process, an Overhead Lifting Device is necessary to lift the center section into the appropriate location.

Use A Chain Hoist Lifting Device

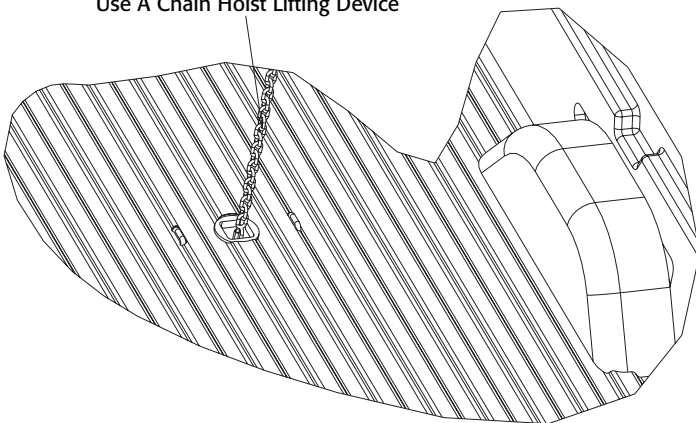

1. Unless the spare tire are in the way, it is not necessary to remove Spare tire off the truck. If the spare tire heat shield existed, remove it to avoid injury.
2. Remove the heat shield located above the rear axle under the truck bed.
3. Detach the tail pipe bracket behind the rear tire on the passenger side. This will make installation easier on all trucks. Diesel trucks will require the tail pipe to be lowered. The bracket will be re-attached.
4. Measure from the back of the truck bed 47" and locate the center of the truck bed (fig. 1)

- A. Mark a spot at the intersection of the two measurements. This is the location of the ball and is critical to the proper operation of the gooseneck flip ball hitch. Double check your measurements.
- B. After confirming the location, make a 4" hole. A hole saw is recommended.
- C. Deburr or grind the hole edges.

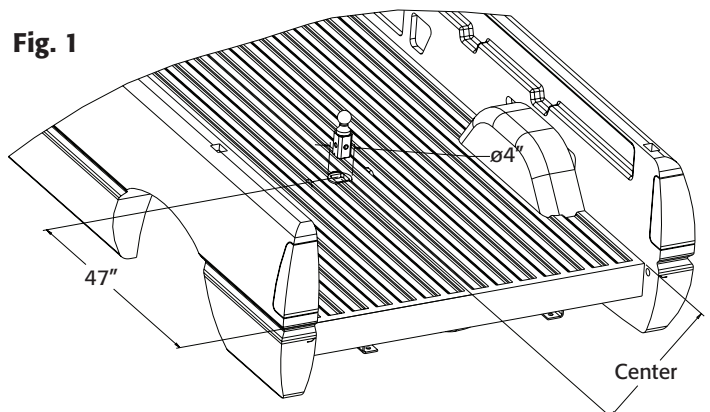

WARNING
 Fuel lines, brake lines, and electrical wires are located along the frame of the truck. When positioning the gooseneck flip ball hitch, care must be taken to avoid damaging these components.

WARNING
 Before installing the gooseneck flip ball hitch, check for adequate turning clearance of the front of your trailer and the truck cab

WARNING
 On 2WD trucks, remove the ball from the socket when carrying heavy loads. Under load, the ball may contact the differential, causing damage.

4.1 For 2004 and older trucks, emergency brake cable and fuel line bracket must be relocated. This is normally located outside of the driver's side frame. Knock the mounting stud out of the frame and use the relocater-bracket provided.

4.2 Exhaust bracket needs to be lowered for diesel engine truck. Detach the tail pipe bracket just behind the rear tire on the passenger side. Relocate the bracket with new bracket later. For gas engine, it is not necessary.

4.3 On gasoline engine truck, it is necessary to relocate a fuel line bracket using the relocating bracket provided. Rotate the existing bracket 90 degrees and mounted it on the newly installed bracket.

5. It may be necessary on some trucks to add a small notch in the flange on the driver's side to allow the cross members to slide between the frame and bed (fig. 2)

Fig. 2

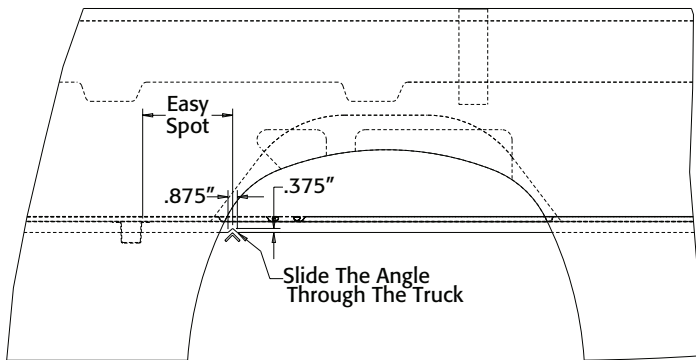

6. Slide the Rear Cross angle through the truck between the frames and the truck bed. Make sure the mounting holes are facing the front of the truck. Roll the bracket upright and slide it toward the 4" holes drilled earlier leaving about 4" space for the center section to lift into place.

7. Repeat for the Front Cross angle of the truck, with the mounting holes facing the rear of the truck. Leave about 8" total clearance between the two cross angles to accommodate for the center section (fig. 3).

Fig. 3

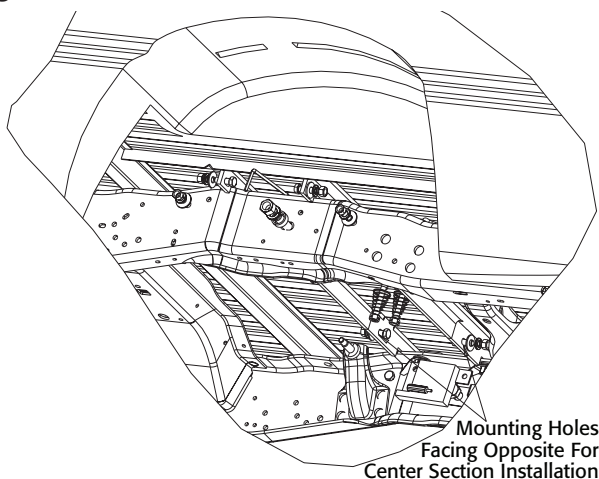

8. Install the Center Section between the two cross angle just installed. Trucks with gasoline engines must detach fuel vent line bracket on the driver side frame. Once the installation is completed, replace the vent line bracket into position. The latch pin slot must be located on the driver side of the truck (fig. 4).

Fig. 4

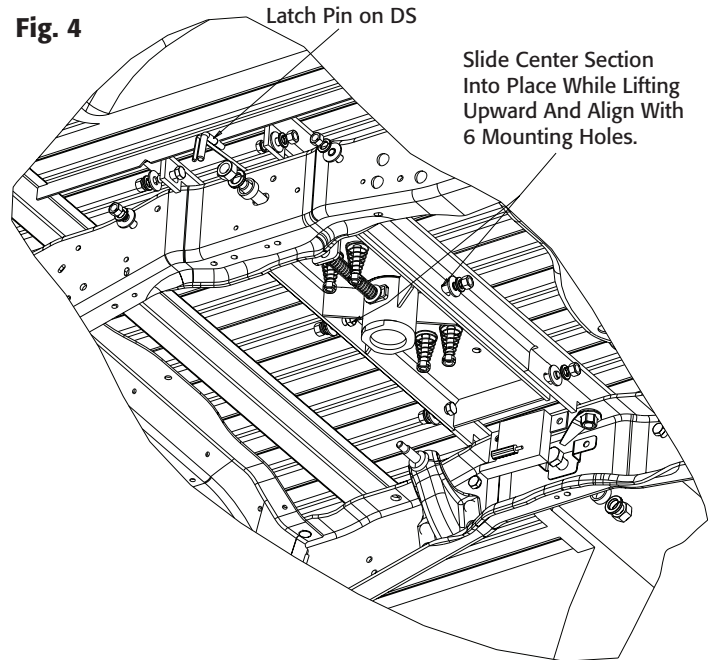

9. Install the Sideplates on the outside of the frame using the 3/4" bolts, washers, and spacers provided. Insert the spacer ring between the sideplate and the truck-frame like a sandwich, to avoid concavity (fig. 5).

Fig. 5

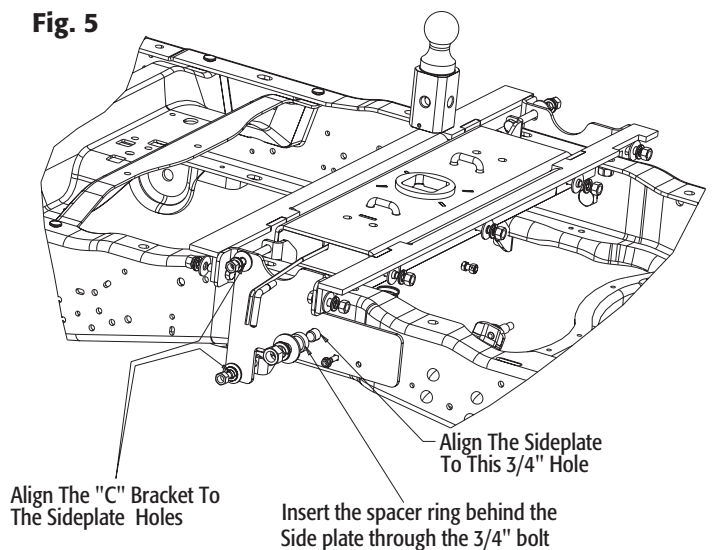

10. Repeat the sideplate installation on the passenger side. If the passenger side is interfered with a sensor device, it must be relocated using the supplied bracket. Caution, do not remove the heat shielding from wire harness. Wiring must remain close to its original position as possible.

11. Tighten the center section to the crossmember at 80 ft. lb. Check to ensure the assembly is square with respect to the frame and truck bed.

12. Install the latch pin release handle from underneath the truck by inserting it through the slot. The head of the bolt must be on the front side of the truck. This is necessary for the handle to be pulled and rotated in order to disengage. You may insert the rubber protector sleeve insert at this time (fig 6).

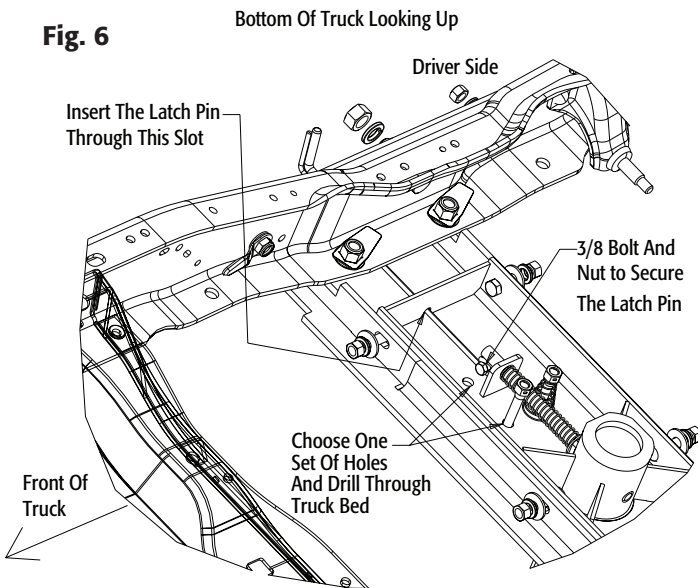

13. To install the u-bolt, it is necessary to drill four 1/2" holes through the truck bed floor. From bottom of the truck, drill upward with the 4 existing holes from the center sections. Use the set of holes that are at the bottom of the floor corrugation if possible. Install the 4 tapered springs into the holes just drilled along with the u-bolts. Secure it with 1/2" nuts provided. Make sure to turn the nuts with all the thread engaged and the springs are pulling the u-bolt downward.

14. Re-attach the Exhaust that was removed earlier. In diesel trucks, use the extension bracket provided. Not all truck models will have available holes on the right side. In that case, one installing bolt is sufficient for this bracket (fig. 7).

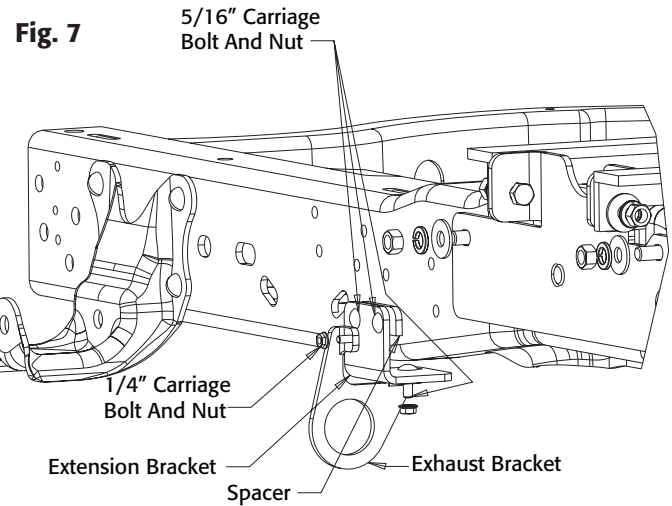

15. Place the 2-5/16" hitch ball into the newly installed hitch. Pull and turn the latch pin to engage the ball with the hitch.

16. Make sure the pin passes through both holes of the hitch. Remove and grease the square base of the ball. Reinstall the heat shield and the spare tire to its original location.

WARRANTY

Buyers Products Co. warrants all truck/trailer hardware manufactured or distributed by it, to be free from defects in material and workmanship for a period of one year from date of shipment. Parts must be properly installed and used under normal conditions. Any product which has been altered, including modification, misuse, accident or lack of maintenance will not be considered under warranty. Normal wear is excluded. The sole responsibility of Buyers Products Co. under this warranty is limited to repairing or replacing any part or parts which are returned, prepaid, and are found to be defective by Buyers Products Co. Authorization from Buyers Products Co. must be obtained before returning any part. No charges for transportation or labor performed on Buyers' products will be allowed under this warranty.

Repair Parts - Gooseneck Hitch Assembly

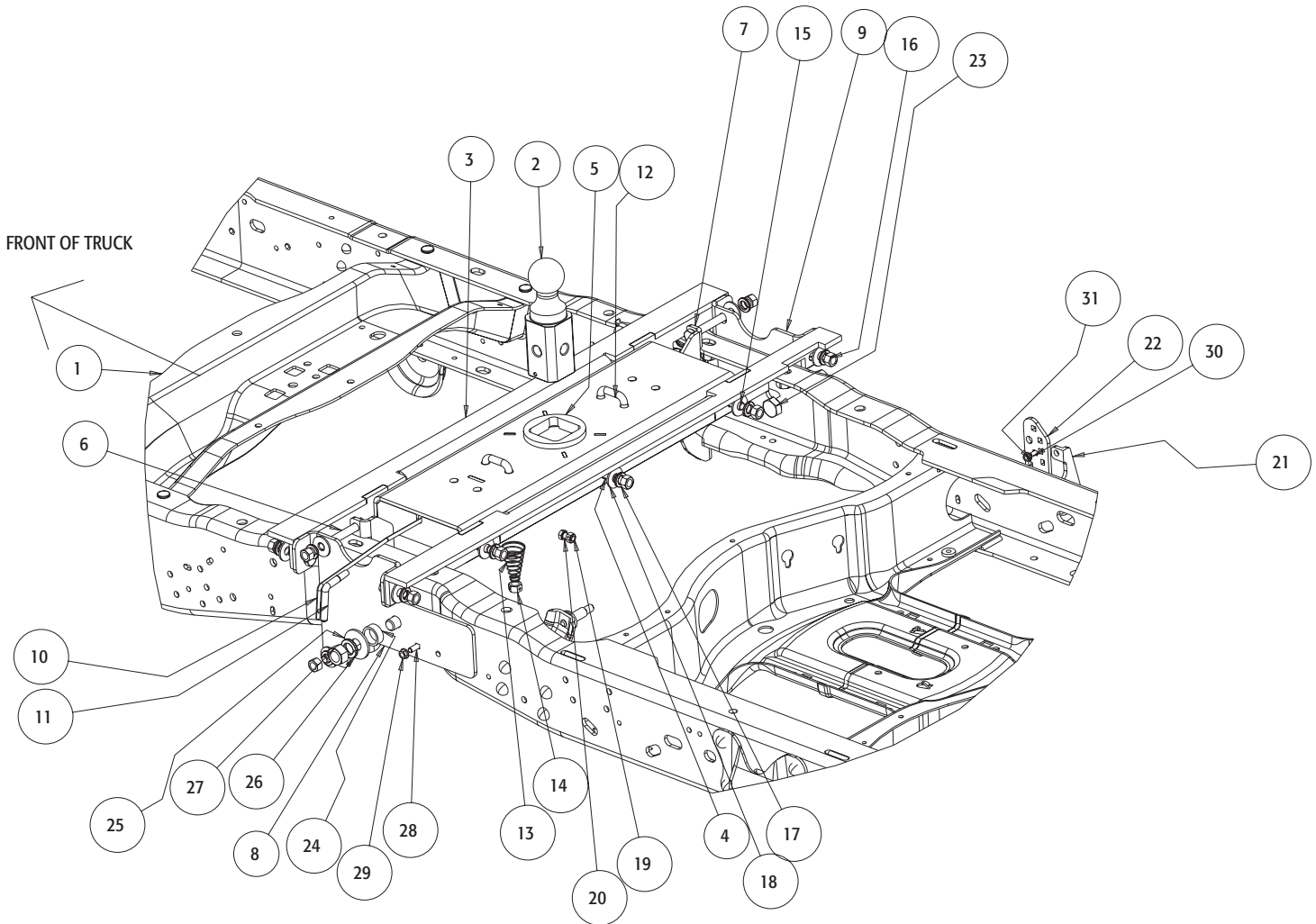

Bill of Materials

ITEM	PART NO.	QTY.	DESCRIPTION
1	-	-	Truck Frame
2	3018195	1	Ball, Flip-Over with Pin
3	3020962	1	Angle, Weldment Front
4	3020961	1	Angle, Weldment Cross
5	3018197	1	Hitch Weldment, Flip-Over
6	3021725	1	Bracket, Brake Line Weld Bolt
7	3021726	1	Bracket, Brake Line Weld Bolt
8	3021521	1	Plate, DS Mount
9	3021522	1	Plate, PS Mount, w/ Square Hole
10	3018211	1	Rod, Pull, ZN
11	3018212	1	Sleeve, Vinly, 1/4 x 4, Black
12	3018214	2	U-Bolt, Square, Special, ZN
13	3018215	4	Spring, Compression, Taper Coil
14	-	4	Nut, Center Lock Hex, 1/2-13 ZN
15	-	10	Screw, Hex-HD 1/2-13 x 1-1/2 Gr. 8 ZN
16	-	14	Nut, 1/2-13 Hex Gr. 8 ZN

ITEM	PART NO.	QTY.	DESCRIPTION
17	-	14	Washer, Lock - 1/2 Split ZN
18	-	14	Washer, Flat, .50 x 1.38 x .14 ZN
19	-	1	Nut, Hex, 3/8-16 x 3/4 CAP
20	-	1	Screw, 3/8-16 x 3/4 CAP
21	-	-	Truck Exhaust Break
22	3018477	1	Bracket, Exhaust Re-locator
23	3000545	2	Cap Screw, Hex-HD 3/4-10 x 2-1/2 Gr. 5 ZN
24	3018438	2	Pipe, Spacer
25	-	2	Washer, FL 3/4 USS ZN
26	-	2	Washer, Lock 3/4 ZN
27	-	2	Nut, Hex 3/4-10 Gr. 5 ZN
28	-	3	Bolt, RHSQN, 5/16-18 x 1 Gr. 5 ZN
29	-	3	Nut, Serrated Flange 5/16-18 ZN
30	-	1	Bolt, Carriage 1/4-20 x 3/4 Gr. 2 ZN
31	-	1	Nut, Serrated Flange, 1/4-20 ZN