

Installation Instructions

5613303 Gooseneck Flip Ball Hitch

Dodge 3500 - 2013+ Long/Short Bed

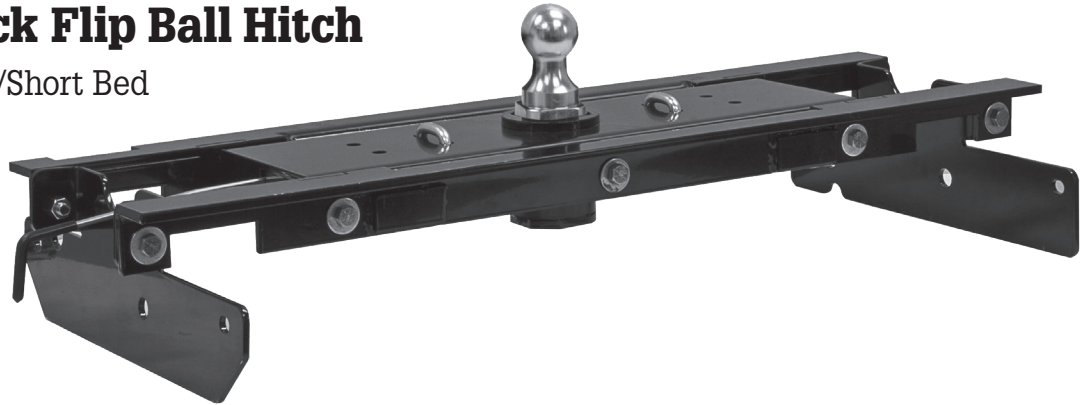

To simplify the installation process, an Overhead Lifting Device is necessary to lift the center section into the appropriate location.

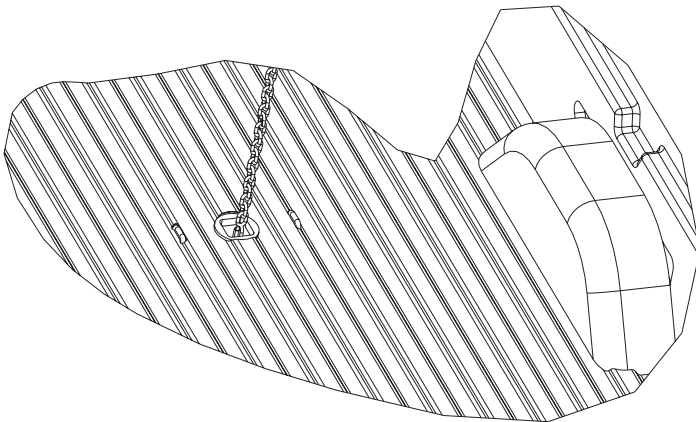

WARNING

Fuel lines, brake lines, and electrical wires are located along the frame of the truck. When positioning the gooseneck flip ball hitch, care must be taken to avoid damaging these components.

WARNING

Before installing the gooseneck flip ball hitch, check for adequate turning clearance of the front of your trailer and the truck cab

WARNING

Cab clearance on short bed trucks is very limited when towing certain trailers. Failure to insure that there will be adequate clearance, may result in significant property damage, or serious injury.

WARNING

On 2WD trucks, remove the ball from the socket when carrying heavy loads. Under load, the ball may contact the differential, causing damage.

1. Remove Spare tire off the truck temporarily for easier installation
2. If the heat shield existed and posed as an interference item, remove it carefully. Cutting and trimming may be necessary.
3. Drill a small pilot hole from the bottom of the truck-bed using the hole-locator tool. It may be easier to mark with a sharpie or sharp tool and center punch from underneath the truck. This hole is the center location of the 3-1/2" hole required to install the gooseneck ball later. Using a circular saw or saw-all, cut the 3-1/2" hole from the top of the truck. Remove/clean up sharp burrs as necessary.

Fig. 1

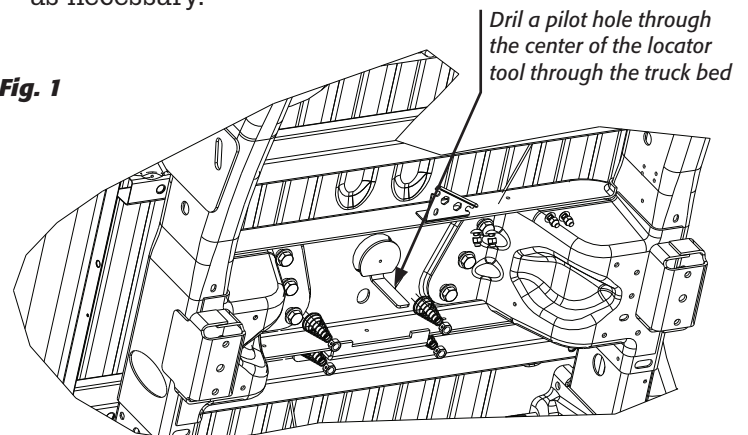

4. Look to the rear passenger side of the truck from underneath, disengage the exhaust from the hanger. This process will free up a lot of space for the center section to move into place. A pry bar may be necessary to lower the exhaust.

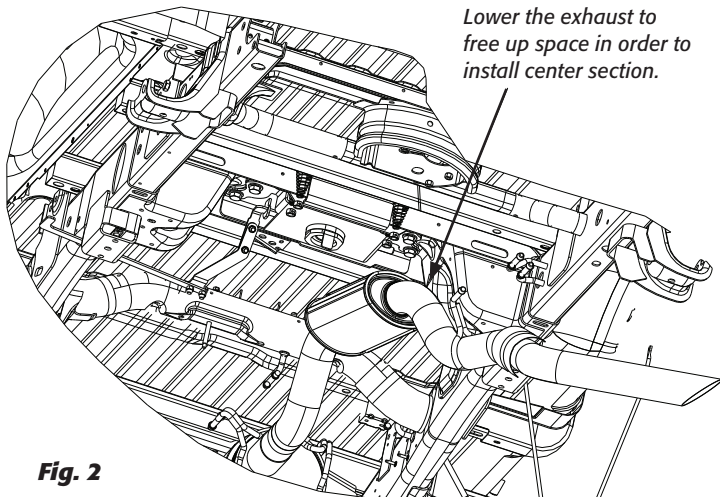

Fig. 2

5. Insert spacer block in between the bed and the frame. Make sure it is center about the 3-1/2 inch hole. Slide the Nut plate on a stick to the left/right of the truck. The holes must align to the plate.

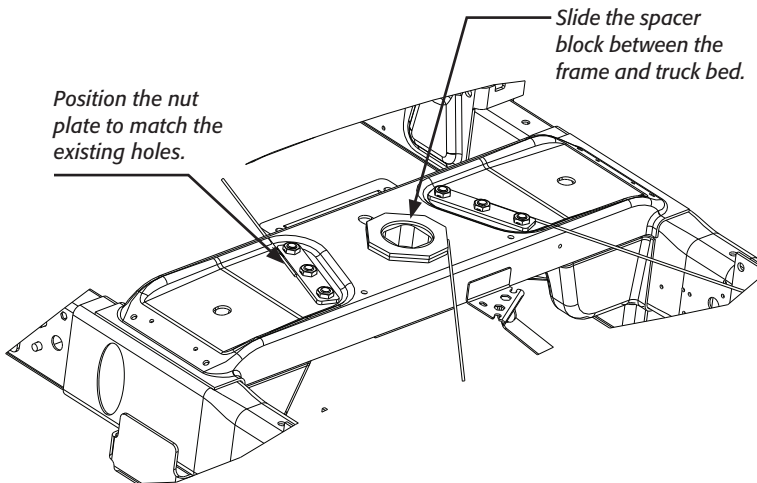

Fig. 3

6. Install the center section into the opening pre-designated for the 6 existing holes. A lifting device is very helpful. Notice the latch handle will default to the driver side because the alignment of the 6 holes will not allow differently. Secure the center section with six 5/8 bolts provided. Torque the bolt to 100 ft-lb. You may cut the excess length of the stick that protruded out too much from the nut plate & spacer block.

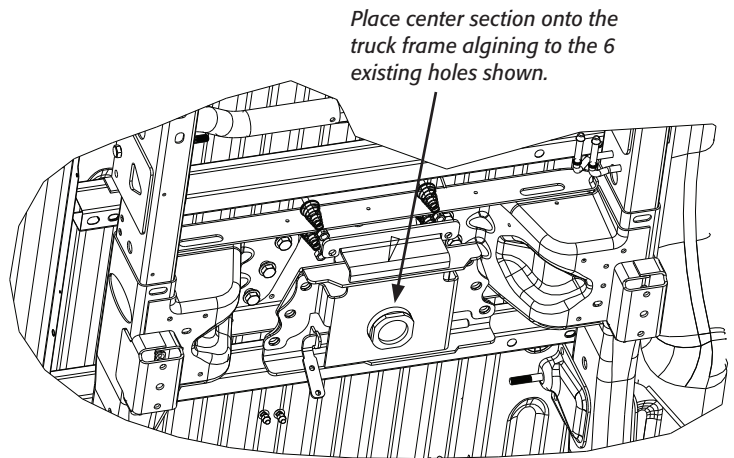

Fig. 4

7. Install the Slider Puller bracket and the Puller Handle onto the center section with the four carriage bolts provided. Tightened bolts to 30 ft-lb.

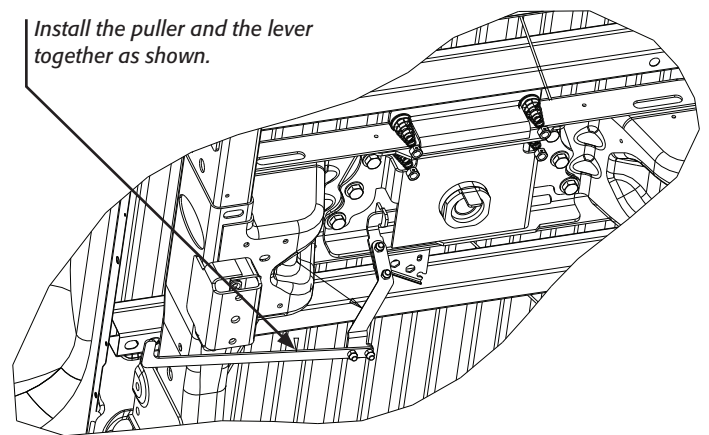

Fig. 5

8. From underneath the bed, on the four safety-chain holes, drill four 9/16 holes up through the truck bed. Two of the holes will have to go through the existing frame structure of the truck. Install the u-bolts through these four holes. Add the four springs from underneath the truck. Secure them with the 1/2 inch nuts provided.

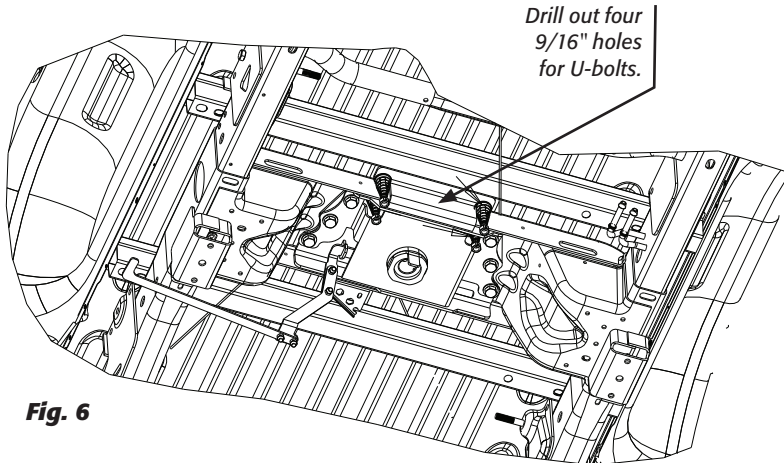

Fig. 6

9. Re-attach the Exhaust that was removed/loosened earlier.
10. Place the 2-5/16" hitch ball into the newly installed hitch. Pull and turn the latch pin to engage the ball with the hitch.
11. Make sure the pin passes through both holes of the hitch. Remove and grease the square base of the ball. Reinstall the spare tire to its original location.

WARRANTY

Buyers Products Co. warrants all truck/trailer hardware manufactured or distributed by it, to be free from defects in material and workmanship for a period of one year from date of shipment. Parts must be properly installed and used under normal conditions. Any product which has been altered, including modification, misuse, accident or lack of maintenance will not be considered under warranty. Normal wear is excluded. The sole responsibility of Buyers Products Co. under this warranty is limited to repairing or replacing any part or parts which are returned, prepaid, and are found to be defective by Buyers Products Co. Authorization from Buyers Products Co. must be obtained before returning any part. No charges for transportation or labor performed on Buyers' products will be allowed under this warranty.

Repair Parts - Gooseneck Hitch Assembly

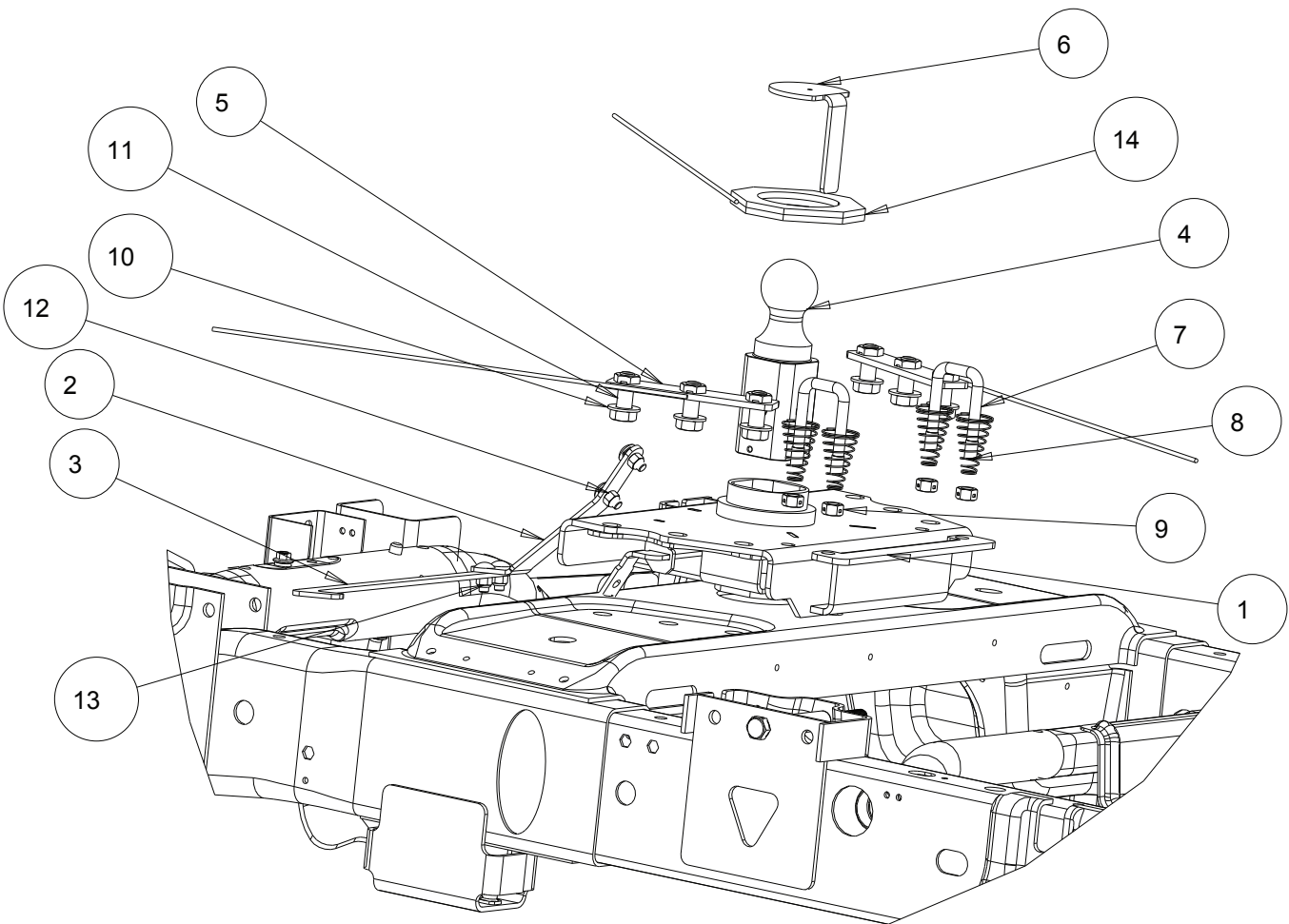

Bill of Materials

ITEM	PART NO.	QTY.	DESCRIPTION
1	3026018	1	GOOSENECK, RAM 3500 WELDMENT
2	3026029	1	SLIDER, PULLER
3	3026033	1	PULLER, ENGAGING
4	3018195	1	BALL, FLIP-OVER, MACHINED
5	3026009	2	PLATE, HEX HOLES
6	3026010	1	LOCATOR, HOLE TEMPLATE
7	3018214	2	U-BOLT, SQUARE ZINC, SPECIAL
8	3018215	4	SPRING, COMPRESSION, TAPER COIL

ITEM	PART NO.	QTY.	DESCRIPTION
9	3002218	4	NUT, CENTER LOCK HEX 1/2-13 ZN
10	FWF063131095	6	WASHER, 5/8 SAE FLAT ZN
11	3009878	6	SCREW,CAP 5/8-11 X 1.5 GR8, ZN
12	FCB037516100	4	BOLT, 3/8-16 X 1 CARRIAGE
13	FNE038016044	4	NUT, NYLOCK 3/8-16 X 7/16 ZINC
14	3026008	1	SPACER, HEX SHAPE WELDMENT