

# Load**LIFTER** 5000™ **ULTIMATE**

ADJUSTABLE AIR HELPER SPRINGS

TOW AND HAUL WITH SAFETY AND COMFORT™



Kit Number  
**88138**

## INSTALLATION GUIDE

For maximum effectiveness and safety, please read these instructions completely before proceeding with installation.

*Failure to read these instructions can result in an incorrect installation.*

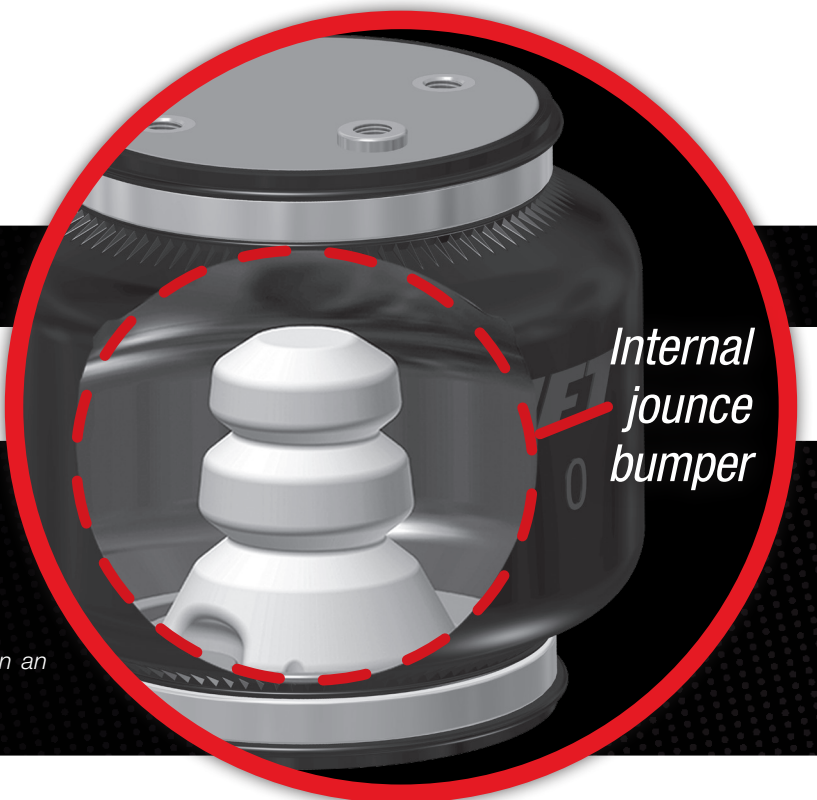



# TABLE OF CONTENTS

<b>Hardware and Tools Lists</b> .....	<b>2</b>
Hardware List .....	2
Tools List .....	2
<b>Introduction</b> .....	<b>3</b>
Notation Explanation .....	3
<b>Installing the LoadLifter 5000 Ultimate System</b> .....	<b>4</b>
Getting Started .....	4
Assembling the Air Spring Unit .....	5
Lowering the Suspension .....	6
Attaching the Upper Bracket .....	6
Attaching the Lower Bracket .....	8
<b>Installing the Air Lines</b> .....	<b>10</b>
Installing the Heat Shield .....	10
Installation Checklist .....	11
<b>Maintenance and Use Guidelines</b> .....	<b>11</b>
Minimum and Maximum Pressure .....	11
<b>Limited Warranty and Return Policy</b> .....	<b>11</b>

# Hardware and Tools Lists

## HARDWARE LIST

Item	Part #	Description.....	Qty
A	58740	Air Springs .....	2
B1	07463	Upper Bracket - Left Hand .....	1
B2	07464	Upper Bracket - Right Hand .....	1
C	03982	Lower Bracket.....	2
D	21837	90-degree Swivel Air Fitting.....	2
E	34365	Heat Shield Kit .....	1
F	10785	3/8"-16 x 6" U-Bolt .....	2
G	01775	Saddle Clamps .....	2
H	17103	5/16"-18 x 1" Hex Head Cap Screws..	2
I	18438	5/16"-18 Nylon Lock Nut.....	2
J	18435	3/8"-16 Nylon Lock Nut.....	6
K	18444	3/8" Flat Washer .....	10
L	17405	3/8"-24 x 3/8"-16 Double End Stud ...	2
M	17203	3/8"-24 x 7/8" Hex Head Cap Screws	6
N	18427	3/8" Lock Washer .....	6
O	11042	Brake Line Bracket Spacer (E-350) ....	1
P	17444	M8 x 20 Bolt.....	1
Q	18501	M8 Stainless Steel Flat Washer .....	3
R	18489	M8 x 1 Nylon Lock Nut .....	1
S	20086	Air Line Assembly .....	1
T	10466	Zip Ties .....	6
U	21230	Valve Caps .....	2
V	21234	Rubber Washer .....	2
W	18411	Stainless Steel Star Washer.....	2
X	21233	5/16" Hex Nut .....	2

## TOOLS LIST

Description.....	Qty
Hoist or floor jack .....	1
Safety stands.....	2
1/2" Drive ratchet .....	1
3/8" Drive ratchet .....	1
18mm Socket .....	1
21mm and 22mm Sockets .....	1
1/2" Socket.....	1
22mm Wrench .....	1
1/2" Wrench.....	1
3/4" Wrench.....	1
Drill .....	1
5/16" drill bit (very sharp) .....	1



Missing or damaged parts? Call Air Lift customer service at (800) 248-0892 for a replacement part.

# Introduction

The purpose of this publication is to assist with the installation and maintenance of the LoadLifter 5000 Ultimate air spring kits. All LoadLifter 5000 Ultimate kits utilize sturdy, reinforced, commercial-grade single or double, depending on the kit, convolute bellows. They also incorporate an internal jounce bumper.

The air springs are manufactured like a tire with layers of rubber and cords that control growth. LoadLifter 5000 Ultimate kits provide up to 5,000 pounds (2,268kg) of load-leveling support with air adjustability from 5-100 PSI (.34-7BAR).

It is important to read and understand the entire installation guide before beginning installation or performing any maintenance, service or repair.

## NOTATION EXPLANATION

Hazard notations appear in various locations in this publication. Information which is highlighted by one of these notations must be observed to help minimize risk of personal injury or possible improper installation which may render the vehicle unsafe. Notes are used to help emphasize areas of procedural importance and provide helpful suggestions. The following definitions explain the use of these notations as they appear throughout this guide.

 **DANGER**

INDICATES IMMEDIATE HAZARDS WHICH WILL RESULT IN SEVERE PERSONAL INJURY OR DEATH.

 **CAUTION**

INDICATES HAZARDS OR UNSAFE PRACTICES WHICH COULD RESULT IN SEVERE PERSONAL INJURY OR DEATH.

 **WARNING**

INDICATES HAZARDS OR UNSAFE PRACTICES WHICH COULD RESULT IN DAMAGE TO THE MACHINE OR MINOR PERSONAL INJURY.

# Installing the LoadLifter 5000 Ultimate System

**CAUTION**

YOUR VEHICLE MAY BE EQUIPPED WITH A REAR BRAKE PROPORTIONING VALVE. ANY TYPE OF LOAD ASSIST PRODUCT COULD AFFECT BRAKE PERFORMANCE. WE RECOMMEND THAT YOU CHECK WITH YOUR DEALER BEFORE INSTALLING THIS TYPE OF PRODUCT. IF YOUR VEHICLE DOES NOT HAVE A REAR BRAKE PROPORTIONING VALVE OR IS EQUIPPED WITH AN ANTI-LOCK TYPE BRAKE SYSTEM, INSTALLATION OF A LOAD ASSIST PRODUCT WILL HAVE NO EFFECT ON BRAKE SYSTEM PERFORMANCE.

**DANGER**

COMPRESSED AIR CAN CAUSE INJURY AND DAMAGE TO THE VEHICLE AND PARTS IF IT IS NOT HANDLED PROPERLY. FOR YOUR SAFETY, DO NOT TRY TO INFLATE THE AIR SPRINGS UNTIL THEY HAVE BEEN PROPERLY SECURED TO THE VEHICLE.

## GETTING STARTED

1. Determine the normal ride height. The normal ride height is the distance between the bottom edge of the wheel well and the center of the hub with the vehicle in the “as delivered” condition. In some cases, Normal Ride Height is not perfectly level.
  - a. Remove unusual loads and examine your vehicle from the side to ensure it is on a level surface.
  - b. If necessary (in cases where your leaf springs are sagging badly), use a jack to raise the rear end so that the vehicle achieves the original “as delivered” ride height.
2. Measure the distance between the center of the hub and the bottom edge of the wheel well (see Fig. 1). This is the normal ride height. Enter the measurement below:

NORMAL RIDE HEIGHT: \_\_\_\_\_ inches/millimeters



*fig. 1*

## ASSEMBLING THE AIR SPRING UNIT

1. The upper brackets are designated “Left” and “Right” indicated by “L” or “R” on the bracket. “L” for the driver’s (left) side and “R” for the passenger’s (right) side (Fig. 2).
2. Install 90 degree swivel air fitting (D) to the top of the air spring. Tighten 1 1/2 turns.
3. Align the right hand upper bracket (B2) with the mounting holes in the air spring and install the 3/8” stud (L) in the outboard tapped hole with the short threaded portion into the air spring (Fig. 3).

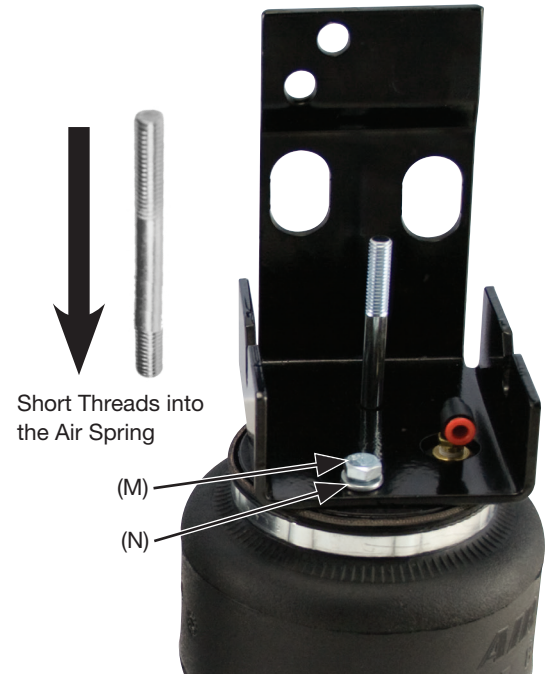
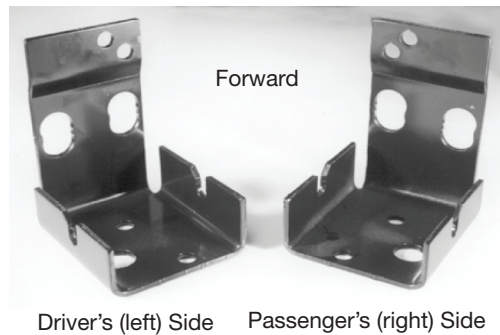

Short Threads into the Air Spring

fig. 2

fig. 3

### NOTE

*Finger tight only. Do not over tighten.*

4. LOOSELY install the 3/8” lock washer (N) and 3/8”-24 x 7/8” hex head cap screws (M). Leave loose to allow installation of the upper bracket.
5. Attach the lower bracket (C) to the bottom of the air spring. Use the forward, inboard hole as shown in Figure 4.

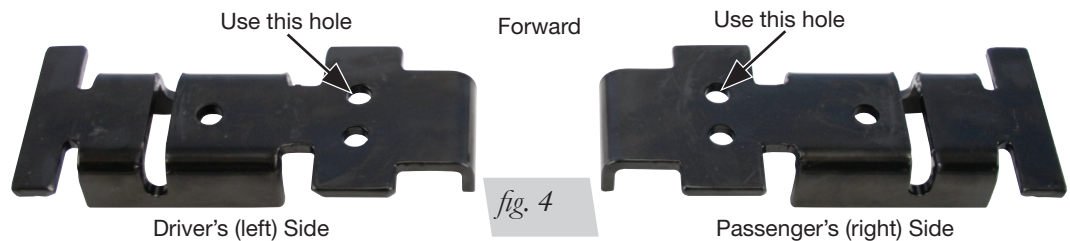

fig. 4

6. Secure lower bracket to the air spring using the 3/8” lock washers (N) and 3/8”-24 x 7/8” hex head cap screws (M). Torque to 20 lb.-ft. (27Nm).
7. This completes the assembly of the passenger’s (right) side (Fig. 5). Now assemble the driver’s (left) side in the same manner.

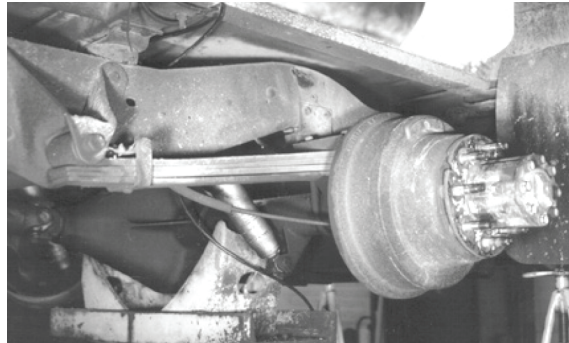

fig. 5

## LOWERING THE SUSPENSION

**NOTE**

*It will be necessary to lower the suspension of the vehicle in order to provide clearance to install the air spring unit (Fig. 6). The following are tips on lowering the axle or raising the frame. Please review them and determine how to proceed:*

*fig. 6*

1. If the vehicle is raised with an axle contact hoist, place axle stands under the frame and lower the axle as needed.
2. If the vehicle is raised with a frame contact hoist, place axle stands under the axle and lower the frame as needed.
3. If the vehicle is raised with a jack and supported with axle stands on the frame, use a floor jack to lower the axle.

## ATTACHING THE UPPER BRACKET

1. Unbolt and remove the rubber jounce bumper from the frame rail and discard (Fig. 7).

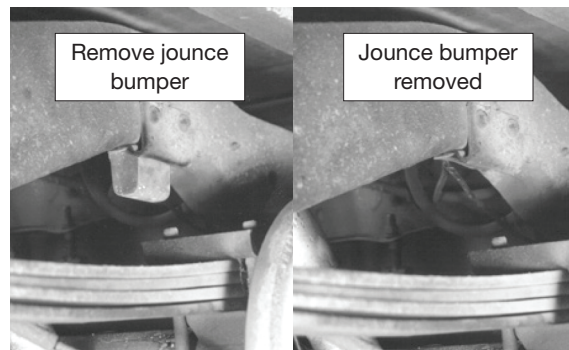
*fig. 7*

2. With the 3/8"-24 x 7/8" hex head bolt (M) loose in the air spring, insert the stud through the original jounce bumper mounting hole (Fig. 8).

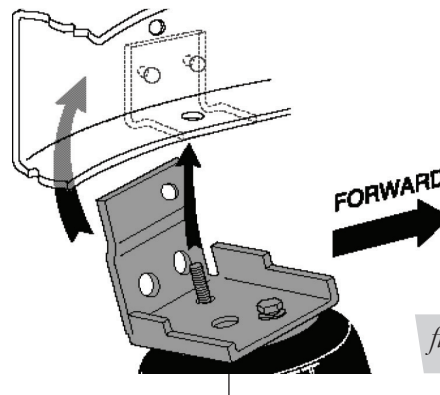
*fig. 8*



- Secure the stud using 3/8" flat washer (K) and 3/8" nylon lock nut (J). See Figure 9. Torque stud nut to 16 lb.-ft. (22Nm).

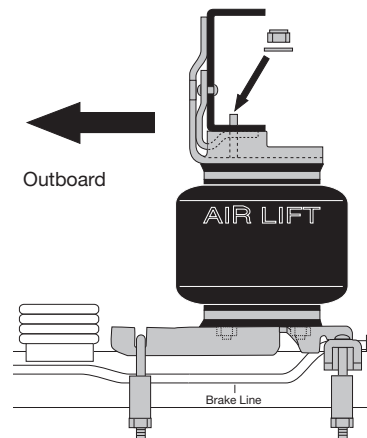

fig. 9

- Tighten the hex head bolt securely to 16 lb.-ft. (22Nm).
- LATE MODELS** have an existing hole that lines up with the top hole in the bracket so it will not be necessary to drill on these models. On some models the existing hole may have a plastic stud for a wiring harness hanger protruding through it. Push the plastic stud back through the frame and use the existing hole to mount the upper bracket to the side of the frame rail.

## NOTE

*If there is a vent tube under the brake line bracket on the driver's side, then the upper bracket will hit on this during installation. This line will have to be relocated on top of the brake line bracket to provide clearance for the upper bracket.*

- If there is no hole, select one of the small holes on the outboard side of the upper bracket that is not on the radius edge of the frame rail.

## CAUTION

DO NOT DRILL HOLES INTO FRAME BEFORE CHECKING FOR HYDRAULIC LINES, GAS LINES AND/OR ELECTRICAL WIRES THAT MAY HAVE TO BE MOVED ASIDE ON EITHER SIDE OF THE FRAME. USING THE UPPER BRACKET AS A TEMPLATE, CENTER-PUNCH THE HOLE LOCATION TO BE DRILLED (FIG. 10A). DRILL A 5/16" HOLE IN THE FRAME RAIL (FIG. 10B).

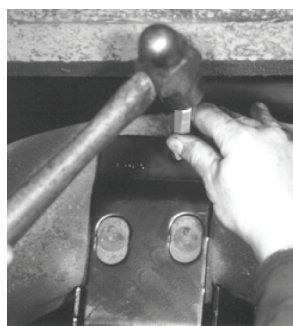

fig. 10a



fig. 10b

- Install 5/16"-18 x 1" hex head cap screws (H), flat washers (K) and 5/16" nylon lock nut (J). Torque to 15 lb.-ft. (20Nm). (Fig. 11).



fig. 11

## ATTACHING THE LOWER BRACKET

**NOTE**

Most late model vehicles have a small brake line hanger on the passenger's side shock bracket that is attached to the brake line (Fig. 12). Remove the bolt holding the wire brake line bracket to the shock mount. Move line aside and attach the brake line bracket spacer (O) to the axle using the existing M8 bolt removed. Attach the stock brake line bracket to the brake line bracket spacer with the M8 bolt (P), washer (Q) and nut (R) provided. Tighten both securely (Fig. 13).

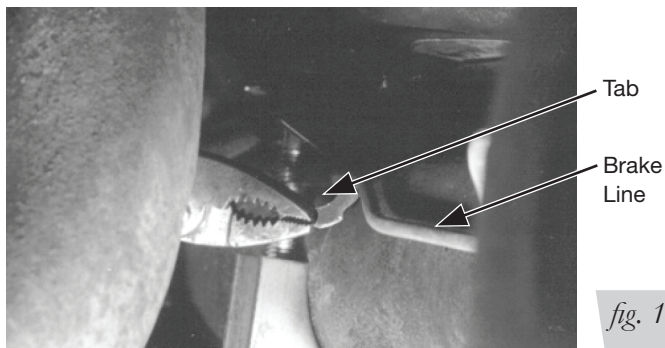

*fig. 12*

*fig. 13*

1. Set the assembly on the axle and check for the following.

**NOTE**

On some models with drum brakes: Check to be sure that the lower bracket is not pinching the brake line on the axle. If it is, then bend the tab holding the brake line away from the axle housing (Fig. 14). Reposition the line and bend the tab back to hold the line in the new position away from the lower bracket leg.

*fig. 14*

2. Position the lower bracket so that the outboard edge is between the leaf spring U-bolts (Fig. 15). Insert the U-bolt (F) provided in the outboard slot of the lower bracket (Fig. 18).



fig. 15

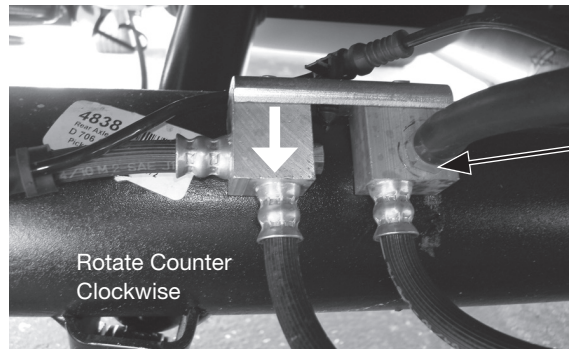

fig. 16

## NOTE

Some late models are equipped with the RSC (roll stability control) system (Fig. 16). On these models, it will be necessary to loosen the axle vent tube bolt and rotate the brake line junction box counter clockwise as far as it will let you. Tighten the axle vent tube bolt securely (Fig. 17).

3. Secure the lower bracket to the axle using the saddle clamps (G), 3/8" flat washers (K) and 3/8" nylon lock nuts (J). See Fig. 18.
4. Torque the nuts to 16 lb.-ft. (22Nm) (Fig. 18). Trim excess bolt off if desired.

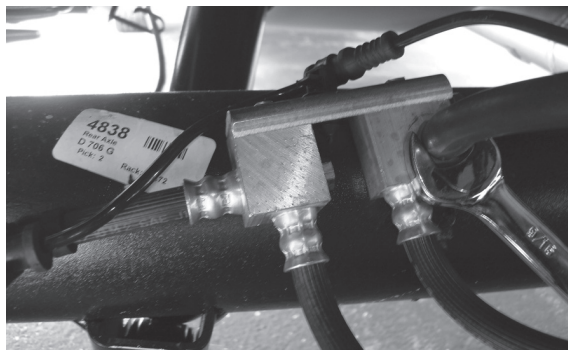

fig. 17

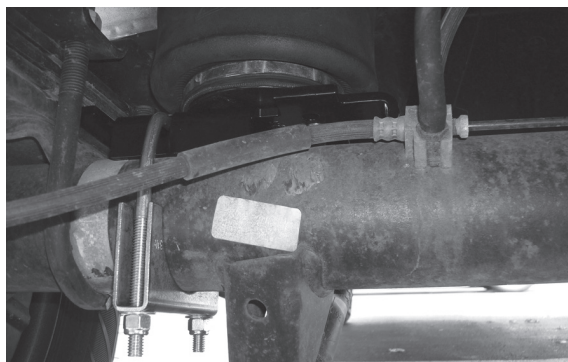

fig. 18

# Installing the Air Lines

Choose the locations for the Schrader valves and drill a 5/16" (8mm) hole, if necessary (Fig. 19).

1. Cut the air line in half. Make clean, square cuts with a razor blade or hose cutter (Fig. 20). Do not use scissors or wire cutters.

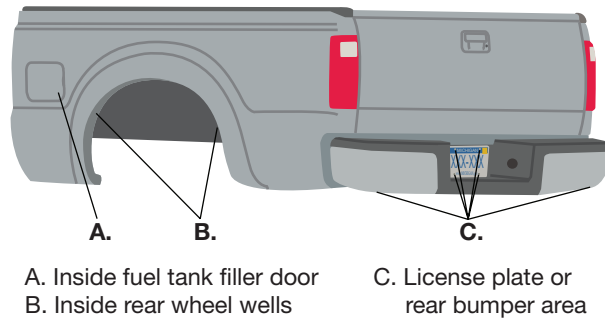

fig. 19

**CAUTION**

KEEP AT LEAST 6" (152MM) OF CLEARANCE BETWEEN ALL AIR LINES AND THE EXHAUST SYSTEM. AVOID SHARP BENDS AND EDGES.

2. Use zip ties to secure the air line to fixed points along the chassis. Do not pinch or kink the air line. Leave at least 2" (51mm) of slack in the air line to allow for any movement that might pull on the air line. The minimum bend radius for the air line is 1" (25mm).

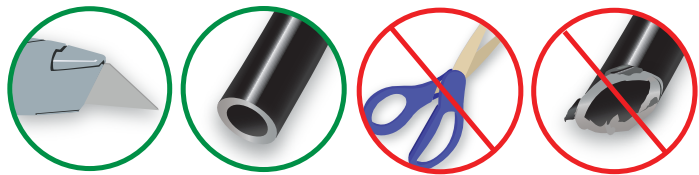

fig. 20

3. Install the Schrader valve in the chosen location (Fig. 21).

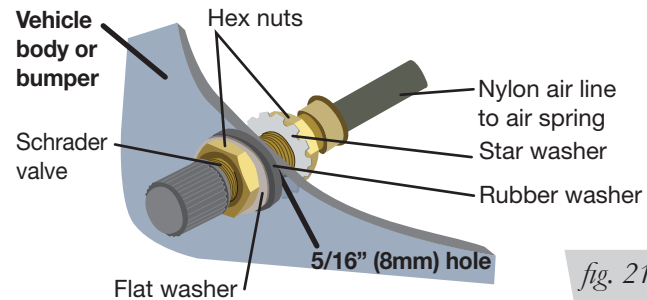

fig. 21

## INSTALLING THE HEAT SHIELD

1. Attach the metal heat shield to the exhaust where it is closest to the passenger's (right) side air spring. Slide the air line thermal sleeve over the air line and position it where the air line is closest to the exhaust. (Fig. 22).

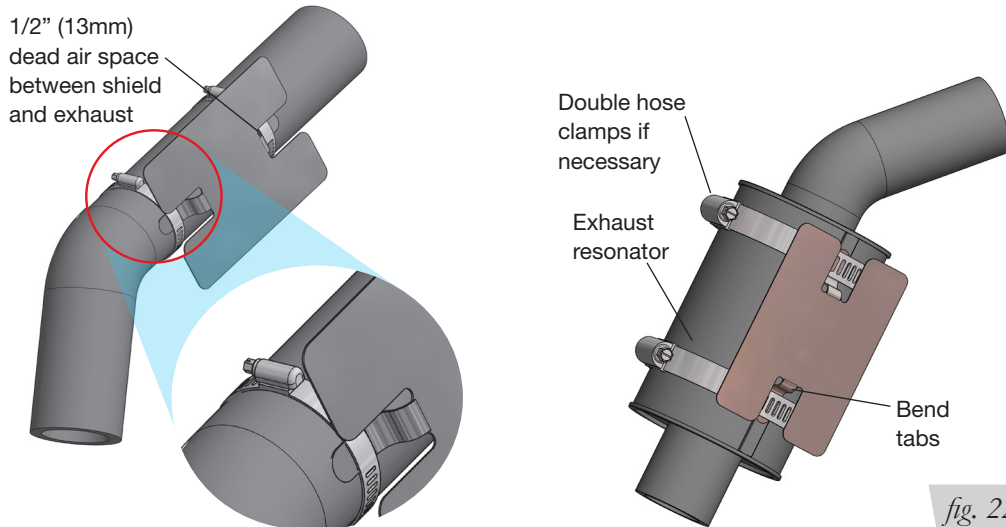

fig. 22

## INSTALLATION CHECKLIST

- Clearance test** — Inflate the air springs to 40-60 PSI (2.8-4.1BAR) and make sure there is at least 1/2" (13mm) clearance from anything that might rub against each sleeve. Be sure to check the tire, brakes, frame, shock absorbers and brake cables.
- Leak test before road test** — Inflate the air springs to 40-60 PSI (2.8-4.1BAR) and check all connections for leaks. All leaks must be eliminated before the vehicle is road tested.
- Heat test** — Be sure there is sufficient clearance from heat sources, at least 6" (152mm) for air springs and air lines. If a heat shield was included in the kit, install it. If there is no heat shield, but one is required, call Air Lift customer service at **(800) 248-0892**.
- Fastener test** — Recheck all bolts for proper torque.
- Road test** — The vehicle should be road tested after the preceding tests. Inflate the springs to recommended driving pressures. Drive the vehicle 10 miles (16km) and recheck for clearance, loose fasteners and air leaks.
- Operating instructions** — If professionally installed, the installer should review the operating instructions with the owner. Be sure to provide the owner with all of the paperwork that came with the kit.

## Maintenance and Use Guidelines

1. Check air pressure weekly.
2. Always maintain normal ride height. Never inflate beyond 100 PSI (7BAR).
3. If the system develops an air leak, use a soapy water solution to check all air line connections and the inflation valve core before deflating and removing the air spring.

Minimum Recommended Pressure	Maximum Air Pressure
5 PSI (.34BAR)	100 PSI (7BAR)



FOR SAFETY AND TO PREVENT POSSIBLE DAMAGE TO THE VEHICLE, DO NOT EXCEED MAXIMUM GROSS VEHICLE WEIGHT RATING (GVWR) OR PAYLOAD RATING, AS INDICATED BY THE VEHICLE MANUFACTURER.



ALTHOUGH THE AIR SPRINGS ARE RATED AT A MAXIMUM INFLATION PRESSURE OF 100 PSI (7BAR), THE AIR PRESSURE ACTUALLY NEEDED IS DEPENDENT ON LOAD AND GROSS VEHICLE WEIGHT RATING.

## Limited Warranty and Return Policy

Air Lift Company provides a limited lifetime warranty to the original purchaser of its load support products, that the products will be free from defects in workmanship and materials when used on cars and trucks as specified by Air Lift Company and under normal operating conditions, subject to the requirements and exclusions set forth in the full Limited Warranty and Return Policy that is available at [www.airliftcompany.com/warranty](http://www.airliftcompany.com/warranty).

For additional warranty information contact Air Lift Company customer service.



# Notes



## Need Help?

Contact Air Lift Company customer service department by calling (800) 248-0892.

For calls from outside the USA or Canada, dial (517) 322-2144.



*Thank you for purchasing Air Lift products — the professional installer's choice!*



Air Lift Company • 2727 Snow Road • Lansing, MI 48917 or P.O. Box 80167 • Lansing, MI 48908-0167  
Toll Free (800) 248-0892 • Local (517) 322-2144 • Fax (517) 322-0240 • [www.airliftcompany.com](http://www.airliftcompany.com)

Printed in the USA  
JJC-0419

California:  WARNING: Cancer and Reproductive Harm - [www.P65Warnings.ca.gov](http://www.P65Warnings.ca.gov)