



**BLUE OX®**

Baseplate Installation Instructions

BX1016

2009 Acura TL

Installation Instructions

Serial Number

Please read BOTH these Installation Instructions and the General Instructions before attempting to install or operate this equipment.

- Blue Ox® towing products and accessories are intended to be installed by Blue Ox® Dealers who are familiar with our products and have the equipment necessary and knowledge to do "fit work". When necessary Blue Ox® Dealers can be found at [www.blueox.us](http://www.blueox.us) or by contacting our Customer Care Department at (402) 385-3051 or toll free (888) 425-5382.
- Many Blue Ox® Baseplates are designed to use existing holes and hardware to mount the baseplate to the towed vehicle. Even though bolts are there, do not assume they are adequate for baseplate mounting. Always use hardware supplied in the hardware kit and existing hardware specified in the Baseplate Installation Instructions.

Attachment Tab Height: 11 1/2"

Attachment Tab Width: 25"

**Bolt Torque Specifications**

Torque in Foot-Pounds for Metric Bolts

Bolt Size	Grade 8.8	Grade 10.9
6MM	6	8
8MM	16	22
10MM	31	40
12MM	54	70
14MM	89	117

Confirm the towability and pre-towing procedures for your vehicle with the owner's manual or contact the vehicle's manufacturer for specific towing procedures.

**Bolt Torque Specifications**

Torque in Foot-Pounds for Inch Bolts

Bolt Size	Grade 5	Grade 8
1/4"	10	14
5/16"	19	29
3/8"	33	47
7/16"	54	78
1/2"	78	119
5/8"	154	230



**! WARNING**

Failure to read and follow these instructions could result in separation of the towed vehicle from the tow bar, causing property damage, loss of towed vehicle, personal injury or death.

# BX1016

# 2009 Acura TL

## Installation Instructions

### Parts List

Ref. No.	Qty.	Part #	Description
1	1	61-6639	WLDM'T, BP, BX1016
2	4	61-5208	WLD, NUT PLT, 1/4X1X1, 3/8"/14"WIRE
3	8	201-0368	3/8-16 X 1 1/4 HEX HEAD BOLT,GRD. 5
4	8	203-0010	3/8 LOCK WASHER, ZP
5	4	202-0090	3/8-16 HEX NYL. INS. LOCK NUT, ZP
6	1	201-0710	6MM-1MM X 50MM H. BOLT, GRD 8.8, ZP
7	1	203-0001	1/4 FLAT WASHER, ZP
8	1	203-0161	6MM, LOCK WASHER, ZP
9	2	201-0979	#12-14 x 1" Self Drilling Screw, ZP
10	2	201-0192	10-32 X 1/2 SLOT, RD. HD. SCREW
11	2	203-0054	#10 LOCK WASHER
12	2	202-0047	#10-32 HEX NUT
13	2	101-5822	ADAPTER, 4 WAY CONNECTOR
14	2	62-3469	ATT TAB ASSY, REM, SF/LB, 1 HOLE
	2	226-0046	BASEPLATE SAFETY CABLE, 36" CL III (N S)
	2	229-0359	QUICKLINK, 3/8, ZP (Not Shown)
	2	290-0437	RECEIVER, CAP PLUG (BLK) (Not Shown)

### Tools Required

10MM Socket	Drill
12MM Socket & Wrench	Flat Screw Driver
9/16" Socket & Wrench	Phillips Screwdriver
Large Vise Grip	Utility Knife
Needle Nose Pliers	Tape Measure
Reciprocating Saw	13/32" Drill Bit
LOCTITE Red	

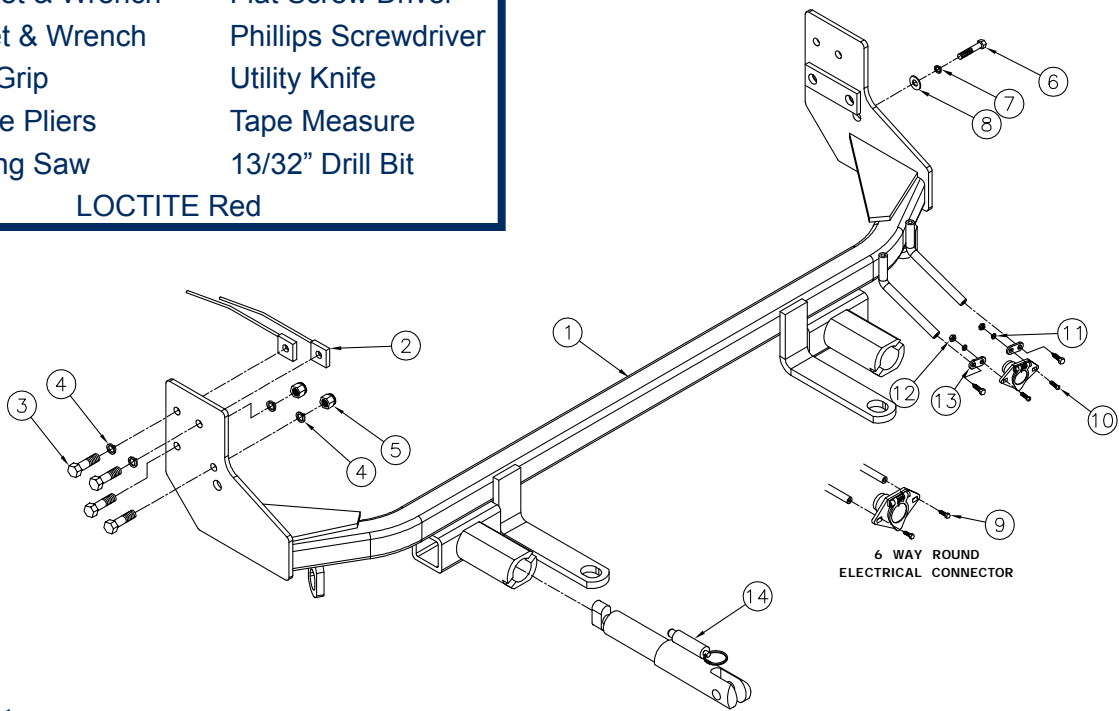

### Important:

Use only genuine factory replacement parts on your baseplate. Do NOT substitute homemade or non-typical parts. If a bolt is lost or in need of replacement, for your safety and the preservation of your baseplate, be sure to use a replacement bolt of the same grade (In most cases it will be Grade 5, please reference the parts list above). Replacement parts may be ordered through your nearest Blue Ox® Dealer or Distributor, or call our 24/7 Customer Care Team at (402)385-3051.

# BX1016

## 2009 Acura TL

### Installation Instructions

#### Attachment Tabs:

Due to the design of the removable tabs, the RangeFinder II and Ambassador tow bars can not be used. Adapters, except the BX8833 and the BX88151, can not be used with this baseplate.

#### Instructions:

The front fascia, headlights, air baffle and bumper are removed for the baseplate installation. Drilling is required. Trimming of the bumper and fascia is required.

The dimensional variations between otherwise identical vehicles can be considerable. While the baseplate was designed for easy installation, it may be necessary to tailor the baseplate slightly to compensate for auto manufacturer's tolerances. These minor adjustments may include filing a hole slightly, bending electrical rods, and/ or bending end plates.

The BX8848 Bulb and Socket Wiring Kit is recommended for this vehicle.

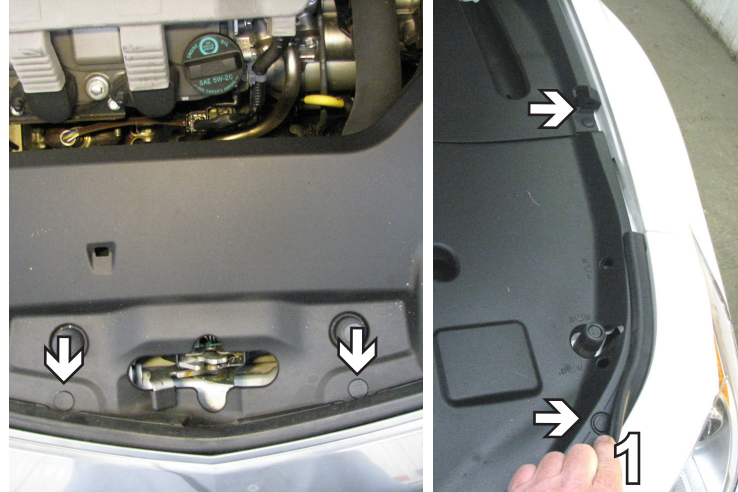

1. Remove six push pins from the plastic above the radiator, three on each side. Remove the plastic from the top of the radiator. Set pushpins aside to reinstall later.

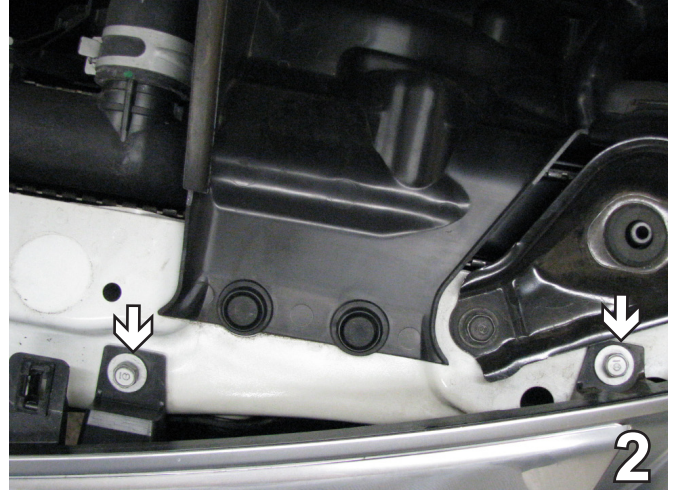

2. On the top side of the fascia, remove two metric bolts with a 10MM socket. Do this on both sides of the vehicle. Set bolts aside to reinstall later.

# BX1016

## 2009 Acura TL

### Installation Instructions

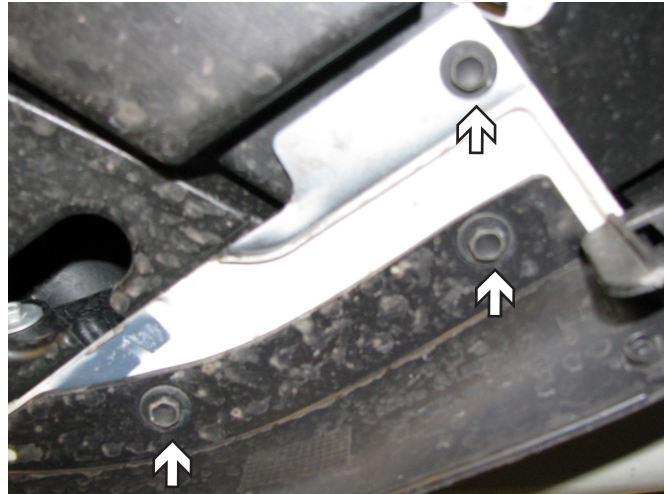
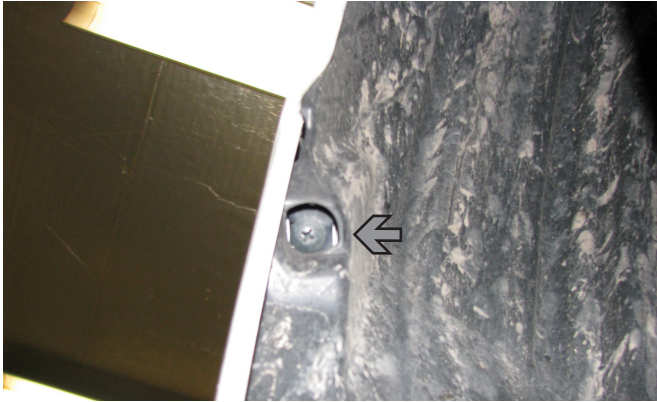

3. Just forward of the front tire, on the edge of the fascia, remove two push pins, as indicated by the white arrows in the photo above. Referenced in the top picture with a gray arrow use a Phillips screw driver to remove one metric bolt. Do this to both sides of the vehicle. Set push pins and bolt aside to reinstall later.

4. Underneath the vehicle along the bottom of the fascia, use a 10MM socket to remove three bolts, white arrows. Also remove the push pin, as indicated by the gray arrow. Do this on both sides of the vehicle. Set bolts and push pins aside to be reinstalled later.

5. Just forward of the front tire remove fascia by pulling out to the side where it meets the fender. While still on the side of the vehicle, pull fascia slightly forward – releasing it from the clips under the headlight assembly. Do the steps above to both sides of the vehicle. Carefully set fascia aside to reinstall later.

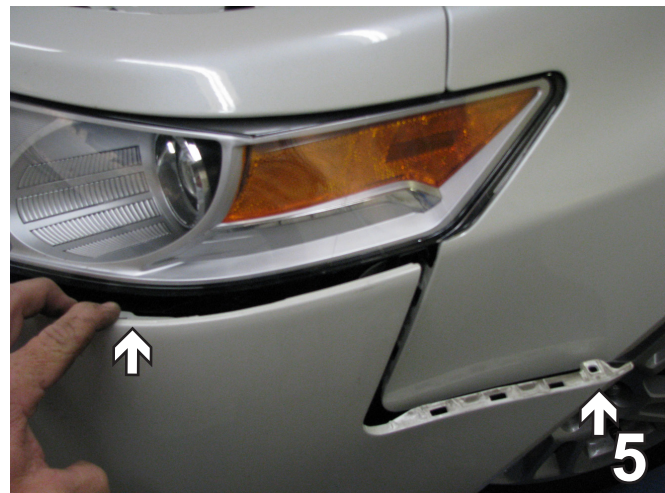

# BX1016

## 2009 Acura TL

### Installation Instructions

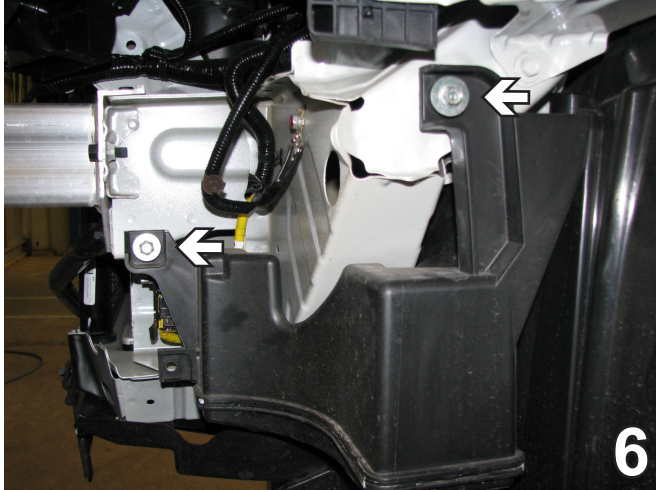

6. On the driver's side, remove the air baffle. Use a 10MM socket to remove the two metric bolts holding it. Set bolts aside to reinstall later.



7. On the driver's side only, just forward of the front tire, remove the Christmas tree push pin. Set air baffle and push pin aside to reinstall later.

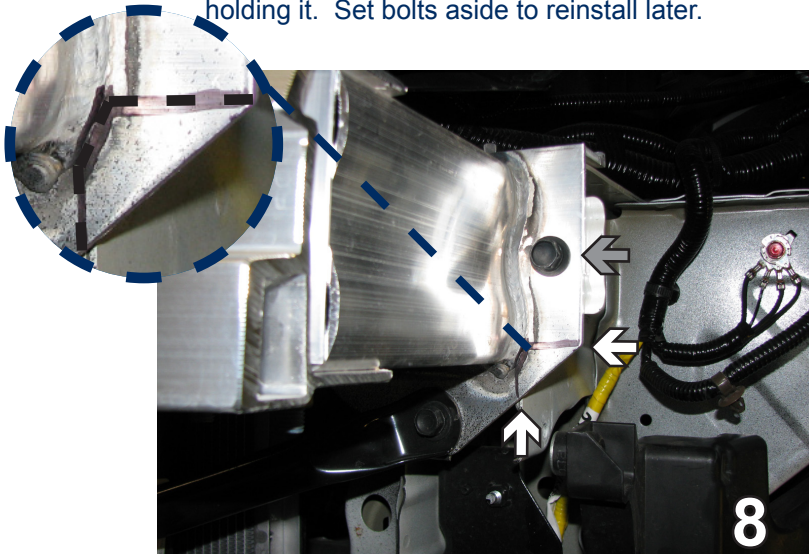

8. The indicated corner will need to be trimmed out of the bumper. Mark the bumper on the back so that the cut will be flush with the bottom of the brace and flush with the side of the frame. After the bumper is removed you can make the cut. Use a 13MM socket to remove the bolt shown with the gray arrow. Do this to both sides of the vehicle. Set the bolt aside to reinstall later.

9. Using a 13MM socket, remove the three remaining metric bolts from the metal bumper. Do this to both sides of the vehicle. Pull bumper forward to remove. Finish cutting notch on bumper bracket on both sides. Set metal bumper and bolts aside to reinstall later.

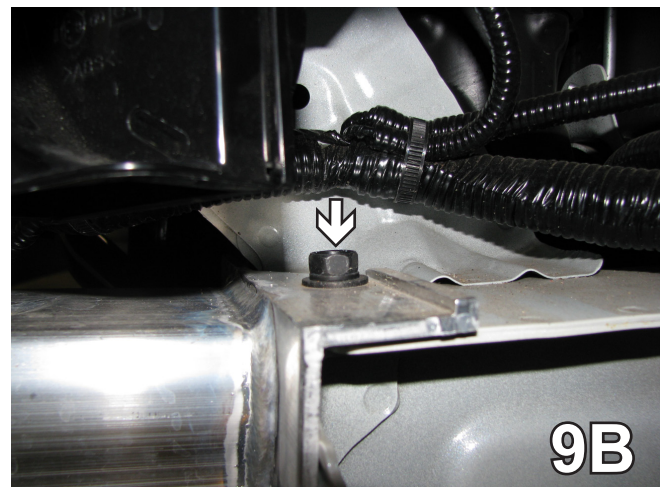
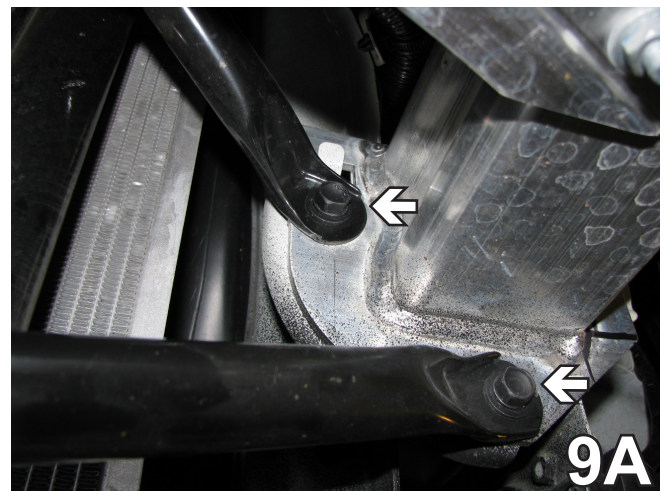

# BX1016

## 2009 Acura TL

### Installation Instructions

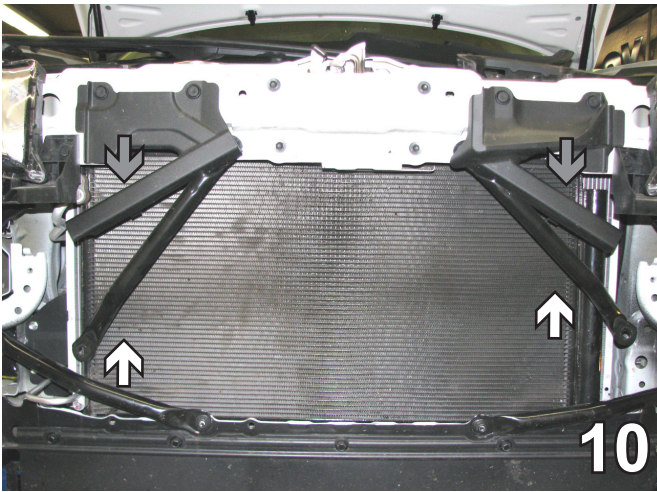

10. If necessary to clear the area for baseplate installation, these plastic braces may be moved out of the way. They just snap on. Be careful not to damage the radiator (gray arrow), then rotate brace out of the way (white arrows).

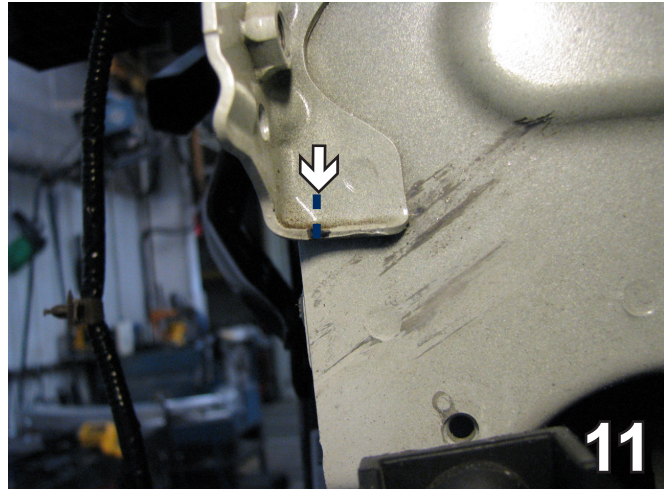

11. On the brace ridge make a cut, then flatten the side down. Do this to both sides of the vehicle.

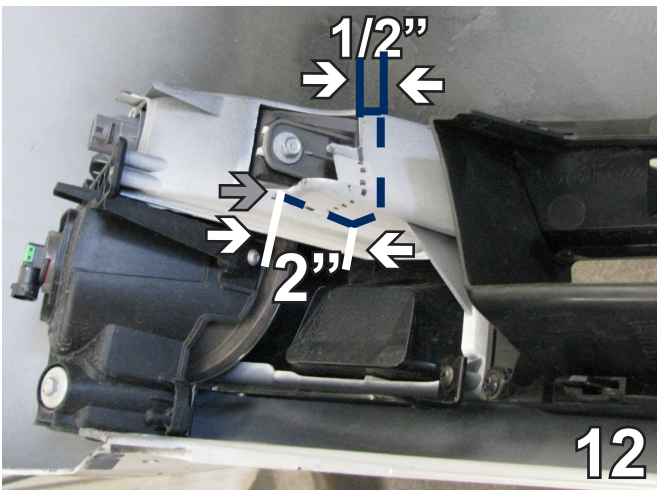

12. On the back side of the fascia, trim around the fog light housing. Make a cut 2" long on the bottom following the inside rib (white arrows) and 1/2" on the top and straight across. Do this to both sides of the fascia.

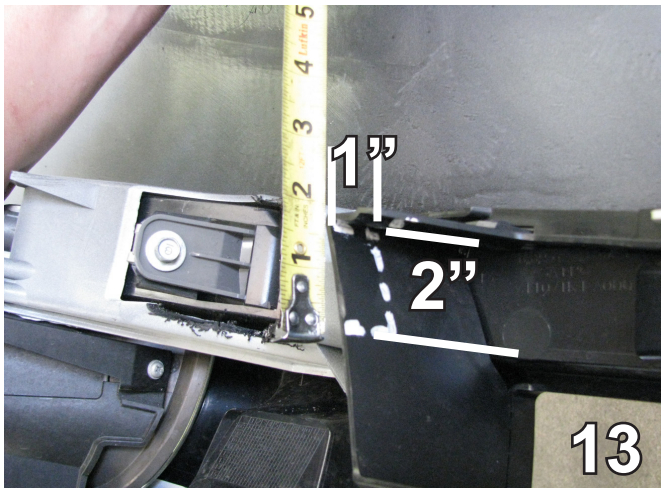

13. Trim 2" down from the top and 1" in straight across on the fascia opening. Do this on both sides of the fascia.

14. Use a vise grip to bend the front air sensor bracket out of the way for baseplate installation. Do this to both sides of the vehicle.



# BX1016

## 2009 Acura TL

### Installation Instructions

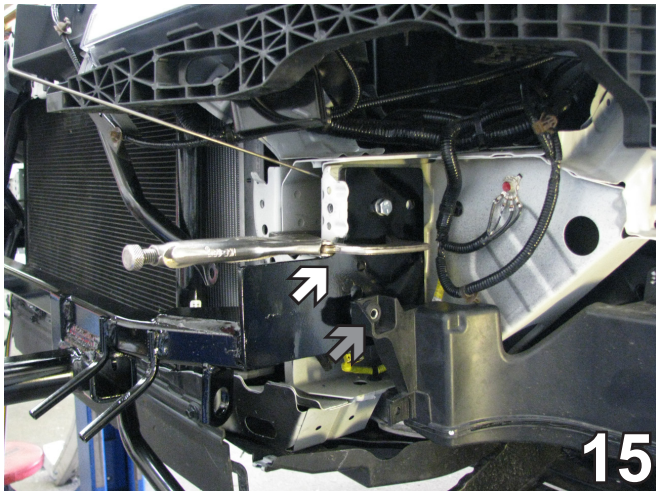

15. Slide the baseplate straight on. Align with the existing lower hole for air baffle on driver's side (gray arrow). Be sure the baseplate is level and clamp with a vise grip. The two lower baseplate holes should align to the middle of doubled lower frame webbing. Using the baseplate as a template, drill the four holes with a 13/32" drill bit. Do this to both sides of the vehicle.

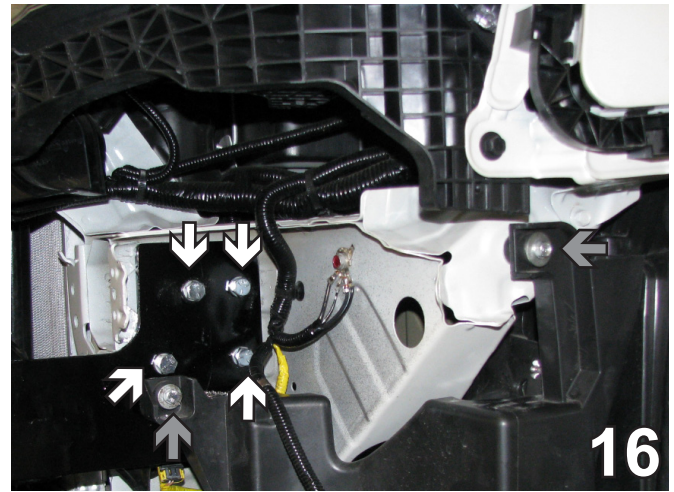

16. Insert 3/8-16 x 1 1/4" hex bolts with the 3/8" lock washer through the baseplate holes on the top. Tighten bolts to the 3/8-16 nut plates placed on hex bolts through opening in frame end. In the bottom holes, insert 3/8-16 x 1 1/4" hex bolts attach to 3/8" lock washers and 3/8-16 nylon insert lock nuts on the back. **Be sure to apply LOCTITE Red to ALL bolts.** Do this to both sides of the vehicle. On the driver's side, reattach the air baffle using the existing bolt on the upper right side. On the lower left (see gray arrow), use 6MM-1.0 x 50 hex nut with 1/4" flat washer and 6MM lock washer.

**BE SURE TO USE LOCTITE® RED ON ALL BOLTS BEFORE TIGHTENING. TIGHTEN ALL BOLTS ACCORDING TO THE TORQUE CHART ON THE FRONT PAGE OF THESE INSTRUCTIONS OR ON PAGE 3 OF THE BASEPLATE TOWING GENERAL INSTRUCTIONS.**

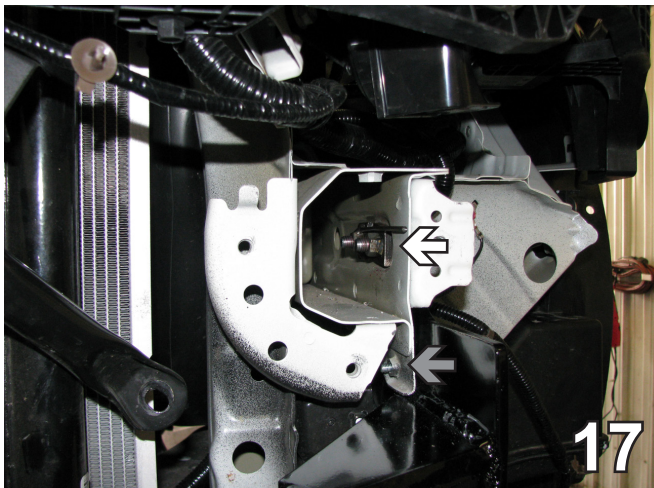

17. Shown are the 3/8-16 nut plates on top (white arrow). The 3/8-16 nylon insert lock nuts on the bottom (gray arrow).

18. Reattach the bumper and braces. Attach the permanent baseplate safety cables to the convenience link on the baseplate and wrap around. The photo shows the recommended installation to the frame of the vehicle. If the vehicle has additional options, which interfere with mounting, secure the cables to a solid piece of the vehicle frame. Be sure the safety cables do not rub against any hoses or moving parts. Do this to both sides of the vehicle. Reattach the fascia.



# BX1016

## 2009 Acura TL

### Installation Instructions

#### **DEALER OR INSTALLER:**

**Be certain the user receives the instruction sheets for their products.**

Reinstall temperature sensor, hose clamps, headlight assemblies, and fascia. Be sure to install all pushpins and bolts.

Baseplate Installation is now Complete.

Install the tow bar and safety cables according to their instructions. When demonstrating this to the customer, be sure to include all of the Blue Ox packaging and contents.

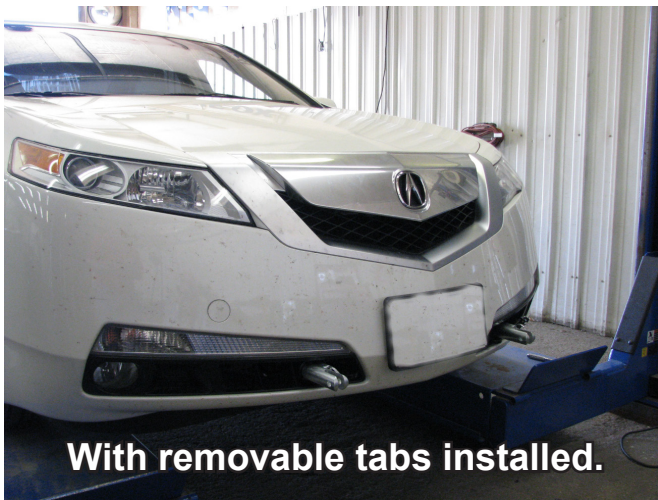

**Be sure that ALL electrical connections are plugged in properly and functioning BEFORE installing the fascia.**

#### **CUSTOMER SERVICE COMMITMENT**

Blue Ox is committed to providing you with exceptional customer care throughout your lifetime with our products. Our team is here to assist you with any questions you may have regarding the performance of your product. Simply call 1-800-228-9289 and you can speak with our customer care team.

Additionally, please visit our website to see which rallies our Destination America team will be attending. For a nominal fee, our service technician will service your towing system to ensure it's in proper working condition. Also as a commitment to our customers, should you visit our factory you can stay at our full service Blue Ox campground at no charge along with enjoying a factory tour.

Again thank you for being our customer and for the confidence you have shown in the performance of our products. It is because of customers like you we enjoy the success we have today.



© 2009 Blue Ox  
One Mill Road, Industrial Park  
Pender, Nebraska 68047  
Phone: (402) 385-3051  
Toll Free: (888) 425-5382  
Fax: (402) 385-3360  
[www.blueox.us](http://www.blueox.us)