



BLUE OX®

Baseplate Installation Instructions

BX1129

2010 Jeep Compass Installation Instructions

Serial Number

Please read **BOTH** these Installation Instructions and the General Towing Instructions before attempting to install or operate this equipment.

- Blue Ox® towing products and accessories are intended to be installed by Blue Ox® Dealers who are familiar with our products and have the equipment and knowledge to do “fit work”. When necessary, Blue Ox® Dealers can be found at www.blueox.com or by contacting our Customer Care Department at (402) 385-3051.
- Many Blue Ox® Baseplates are designed to use existing holes and hardware to mount the baseplate to the towed vehicle. Even though bolts are there, do not assume they are adequate for baseplate mounting. Always use hardware supplied in the hardware kit or existing hardware specified in the Baseplate Installation Instructions.

Attachment Tab Height: 16”
Attachment Tab Width: 25”

Bolt Torque Specifications

Torque in Foot-Pounds for Metric Bolts

Bolt Size	Grade 8.8	Grade 10.9
6MM	6	8
8MM	16	22
10MM	31	40
12MM	54	70
14MM	89	117

Confirm the towability and pre-towing procedures for your vehicle with the owner’s manual or contact the vehicle’s manufacturer for specific towing procedures.

Bolt Torque Specifications

Torque in Foot-Pounds for Inch Bolts

Bolt Size	Grade 5	Grade 8
1/4”	10	14
5/16”	19	29
3/8”	33	47
7/16”	54	78
1/2”	78	119
5/8”	154	230



If the front of your vehicle looks different than this, call us at (402) 385-3051.

! WARNING

Failure to read and follow these instructions could result in separation of the towed vehicle from the tow bar, causing property damage, loss of towed vehicle, personal injury or death.

BX1129

2010 Jeep Compass

Installation Instructions

Parts List

Ref. No.	Qty.	Part #	Description
1	1	61-6791	Weldment, Baseplate, BX1129
2	12	61-5208	3/8" Nut Plate, with Wire
3	2	102-6753	Spacer, Driver's Side, BX1975
4	2	201-0404	3/8-16 x 1 3/4" Hex Bolt, Grd. 5, ZP
5	10	201-0440	3/8-16 1 1/2" Hex Bolt, Grd. 5, ZP
6	12	203-0010	3/8" Lock Washer, ZP
7	2	201-0979	#12-14 x 1" Self Drilling Screw, ZP
8	2	201-0192	#10-32 x 1/2" Slot, Rd. Hd. Screw
9	2	203-0054	#10 Lock Washer
10	2	202-0047	#10-32 Hex Nut
11	2	101-5822	Adapter, 4 Way Connector
12	2	62-3468	Attachment, Assembly, SF/SB (R)
	1	201-0050	1/4-20 X 3/4 Hex Bolt Grd.5, ZP (not shown)
	1	202-0069	1/4-20 Hex Flange Whiz Lock Nut, ZP (not shown)
	2	226-0046	Permanent Baseplate Safety Cables, CL III (not shown)
	2	229-0359	3/8" Quick Link, ZP (not shown)
	2	290-0437	Cap Plug, Black (not shown)
	2	290-0159	13 Inch Nylon Cable Tie (not shown)

Tools Required

- 7mm Socket
- 10mm Socket
- 13mm Socket
- 1/4" Socket
- 9/16" Socket
- T-20 Torx Socket
- Large Vise Grips
- Reciprocating Saw
- Drill
- Flat Screwdriver
- Torque Wrench
- Tape Measure
- 1 1/4" Hole Saw
- 13/32" Drill Bit
- Loctite® RED

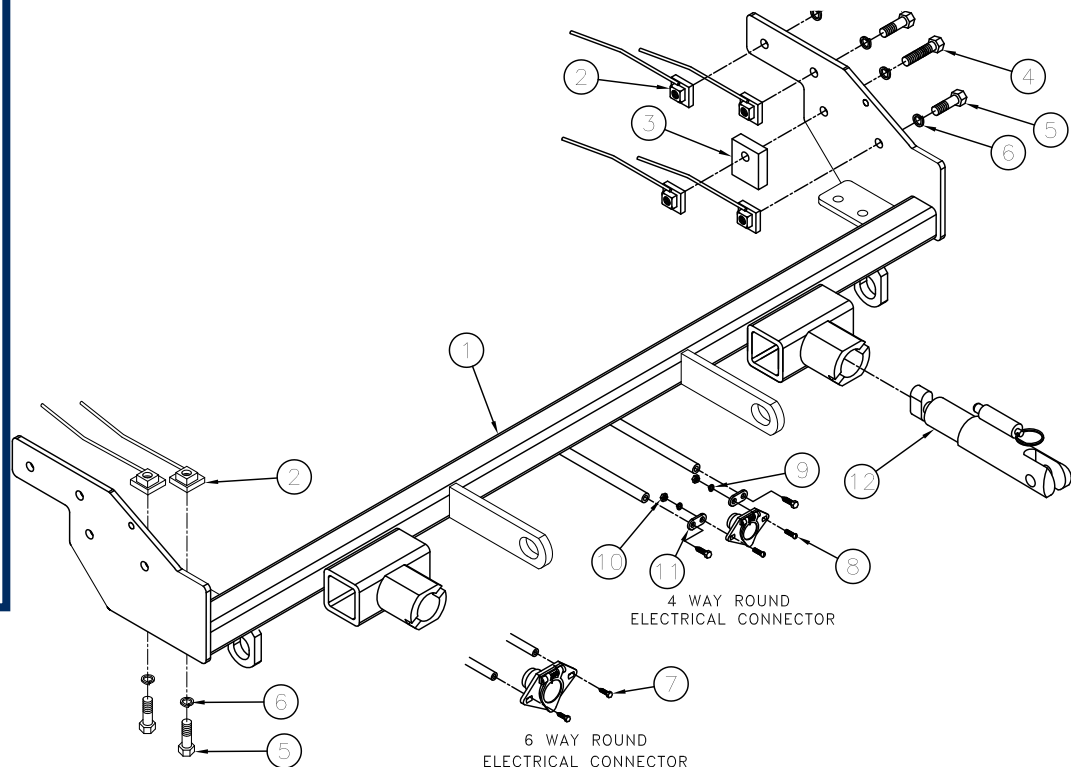

Important:

Use only genuine factory replacement parts on your baseplate. Do **NOT** substitute homemade or non-typical parts. If a bolt is lost or in need of replacement, for your safety and the preservation of your baseplate, be sure to use a replacement bolt of the same grade (In most cases it will be Grade 5, please reference the parts list above). Replacement parts may be ordered through your nearest Blue Ox® Dealer or Distributor. Failing to follow and/or altering these installation instructions in either installation or required equipment will void the manufacturer's warranty. Towing behind a non-motorized vehicle will void the warranty.

BX1129

2010 Jeep Compass

Installation Instructions

Attachment Tabs:

Due to the design of the removable tabs, the RangeFinderII tow bar can not be used. Adapters, except the BX8833 and BX88151, can not be used with this baseplate.

Installation Notes: The fascia and horn are removed for installation. Trimming of the metal bumper is required. Drilling is required.

The dimensional variations between otherwise identical vehicles can be considerable. While the baseplate was designed for easy installation, it may be necessary to tailor the baseplate slightly to compensate for auto manufacturer's tolerances. These minor adjustments may include filing a hole slightly, bending electrical rods or bending end plates.

The BX8869 Bulb and Socket Wiring Kit is recommended for this vehicle.

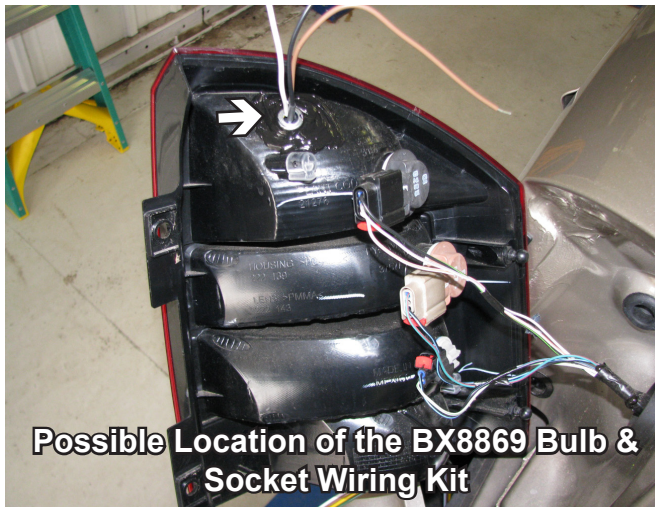

Handling of some cosmetic parts when installing this product may require the use of protective covers, rags, specialty tools, etc. to prevent damage.

Installation Instructions:



1. Remove one bolt from above the headlight using the 10mm socket. Do this to both sides of the vehicle. Set bolts aside to be reinstalled later.

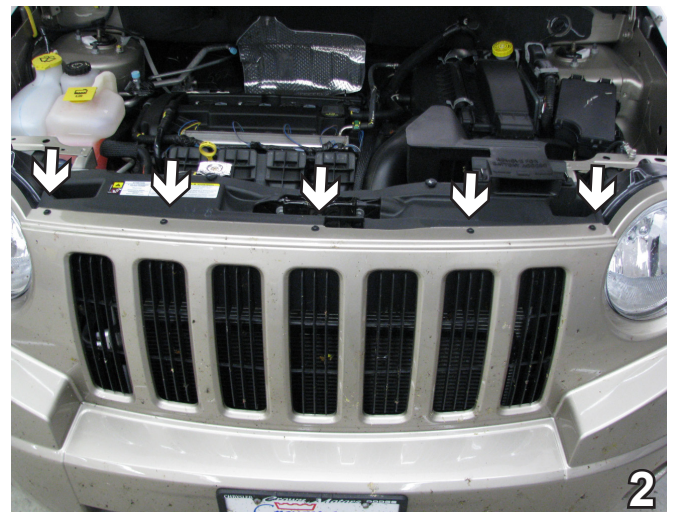

2. Remove five bolts from the top of the fascia using the 20-Torx socket. Set bolts aside to be reinstalled later.

BX1129
2010 Jeep Compass
Installation Instructions



3. Remove three metric bolts using the 7mm socket, just inside wheel well, on edge of fascia. Do this to both sides of the vehicle. Set bolts aside to be reinstalled later.



4. Remove two pushpins just forward of the front tire, on the underside of fascia. Do this to both sides of the vehicle. Set pushpins aside to be reinstalled later.



5. Remove three metric bolts from bottom of fascia, using the 10mm socket. Do this to both sides of the vehicle. Set bolts aside to be reinstalled later.



6. Push wheel well cover aside to remove one metric bolt using the 10mm socket. Do this to both sides of the vehicle. Pull fascia forward to remove. Set bolts and fascia aside carefully to be reinstalled later.

BX1129

2010 Jeep Compass

Installation Instructions

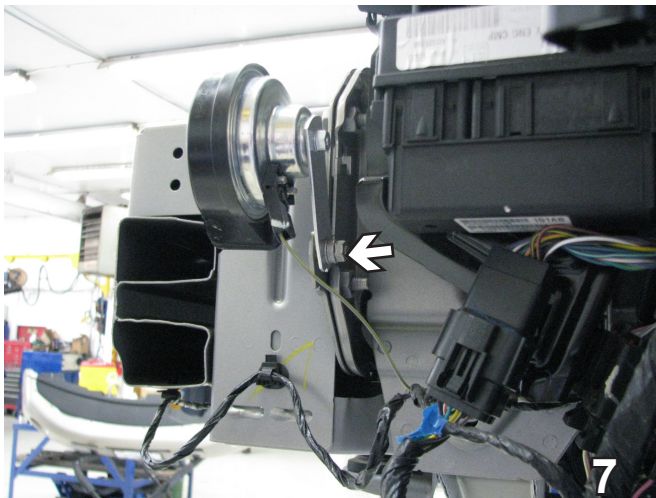

7. On the driver's side, using the 10mm socket, remove the metric bolt from the bottom of the horn bracket. Set the horn and bolt aside to be reinstalled later.

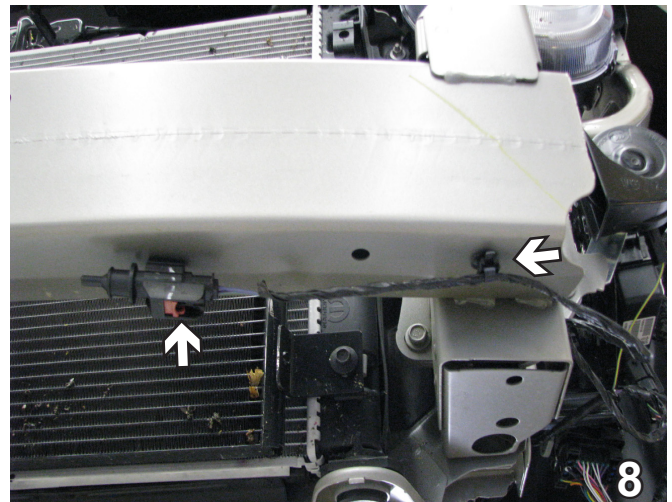

8. On the driver's side, disconnect sensor wire from the side of the frame and the bottom of metal bumper to clear area for cutting. Set sensor wire aside to be reinstalled later.

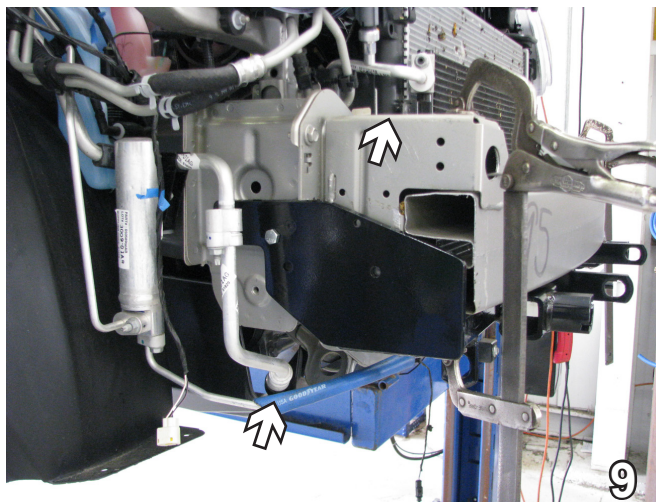

9. On the passenger's side, pry the coolant tubing clips from the side of the frame rail. Move the tubing to the top of the frame to clear the area for cutting. After the baseplate has been installed, return the tubing to its original location.

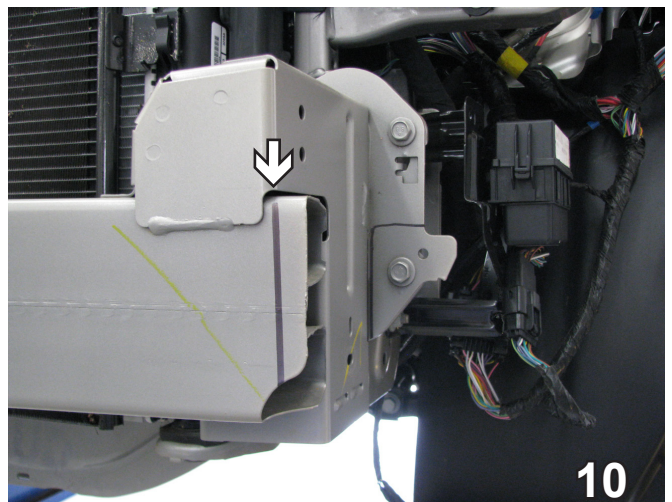

10. Using the reciprocating saw, cut the end of the bumper straight down so that it is flush with the frame. Do this to both sides of the vehicle.

BX1129
2010 Jeep Compass
Installation Instructions

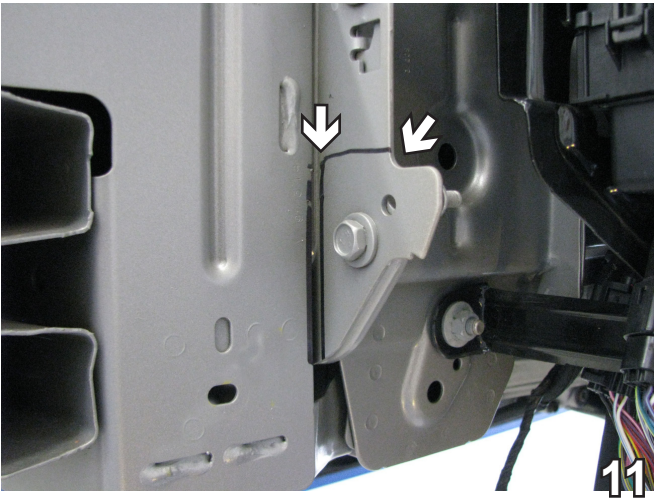

11. Using the reciprocating saw, start cutting even with the bottom of the weld. Cut horizontally until reaching the frame rail. Then, cut vertically until reaching the bottom of webbing. Do this to both sides of the vehicle.

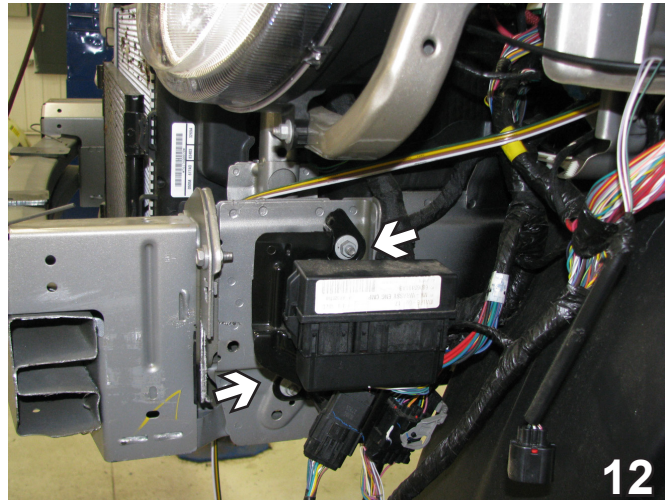

12. On the driver's side, using a 13mm socket remove two metric bolts. Pull the box away in order to install the baseplate.

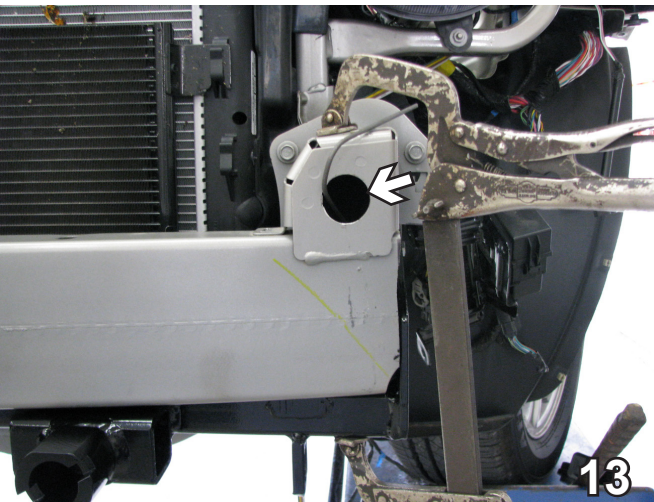

13. Using the 1 1/4" hole saw, drill into the front of the frame rail (to open an area to insert nut plates). Do this to both sides of the vehicle.

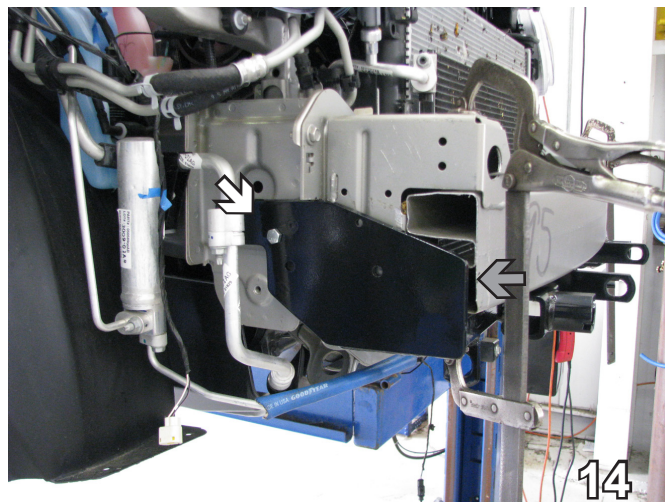

14. On the passenger's side, slide baseplate in line with the existing hole (see white arrow). Baseplate will be 1/4" from edge of the bumper (see grey arrow). Clamp in place using the vise grips.

BX1129

2010 Jeep Compass

Installation Instructions

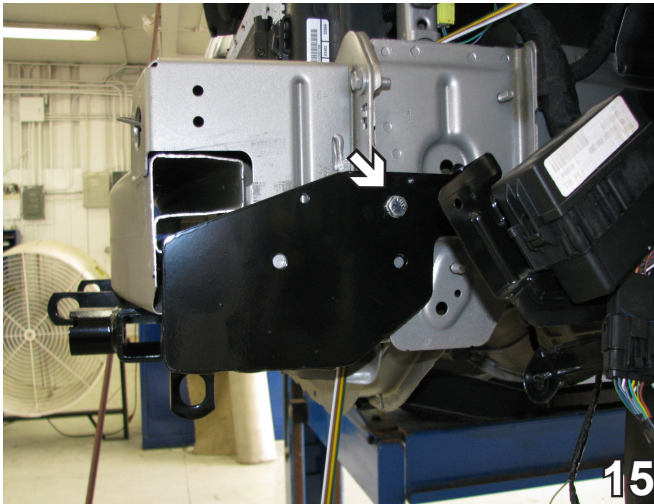

15. Insure the baseplate is level with respect to the vehicle frame. Using the baseplate as a template, drill one hole into frame with the 13/32" drill bit. Install 3/8-16 x 1 1/2" hex bolt with 3/8" lock washer and 3/8-16 nut plate and tighten. Do this on both sides of the vehicle.

When using power drills be aware of the dangers of torque and drill bit length.

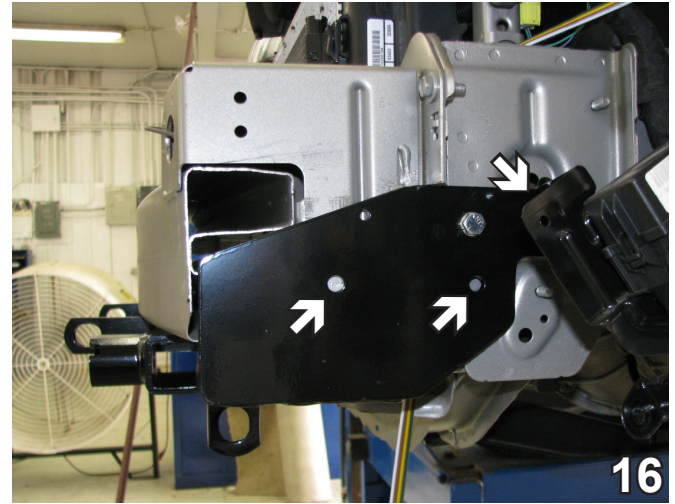

16. Using the baseplate as a template, drill three remaining holes into frame rail with the 13/32" drill bit. Do this on both sides of the vehicle.

BE SURE TO USE LOCTITE® RED ON ALL BOLTS BEFORE TIGHTENING. TIGHTEN ALL BOLTS ACCORDING TO THE TORQUE CHART ON THE FRONT PAGE OF THESE INSTRUCTIONS OR ON PAGE 3 OF THE BASEPLATE TOWING GENERAL INSTRUCTIONS.

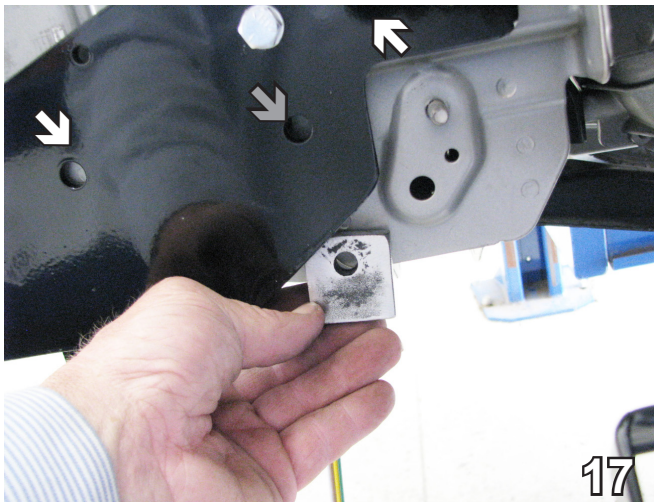

17. Align the spacer between frame and the lower middle hole of baseplate. Install the 3/8-16 x 1 3/4" hex bolt with 3/8" lock washer, 3/8-16 nut plate and tighten (see grey arrow). Insert 3/8" nut plates through through the frame end and align to upper holes (see white arrows). Install 3/8-16 x 1 1/2" hex bolts with 3/8" lock washers, and tighten. Trim excess nut plate wires. Do this on both sides of the vehicle.

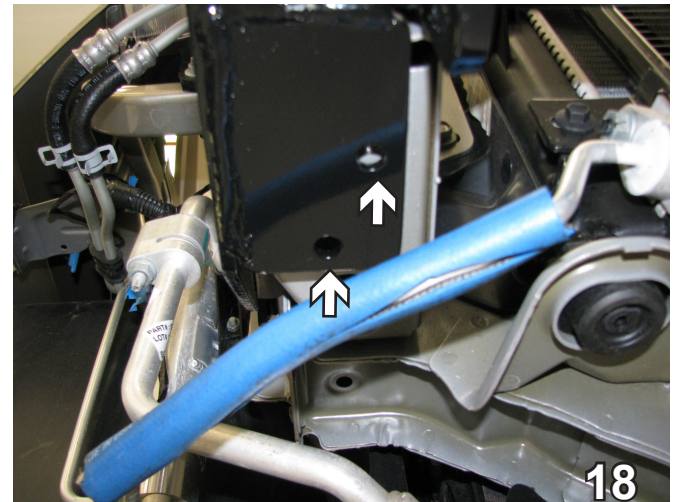

18. Using the baseplate as a template, drill the two holes into the underside of the frame with the 13/32" drill bit. Install 3/8-16 x 1 1/2" hex bolts with 3/8" lock washers and 3/8-16 nut plates and tighten. Be sure to use Loctite Red on all bolts before tightening. Do this on both sides of the vehicle.

BX1129

2010 Jeep Compass

Installation Instructions

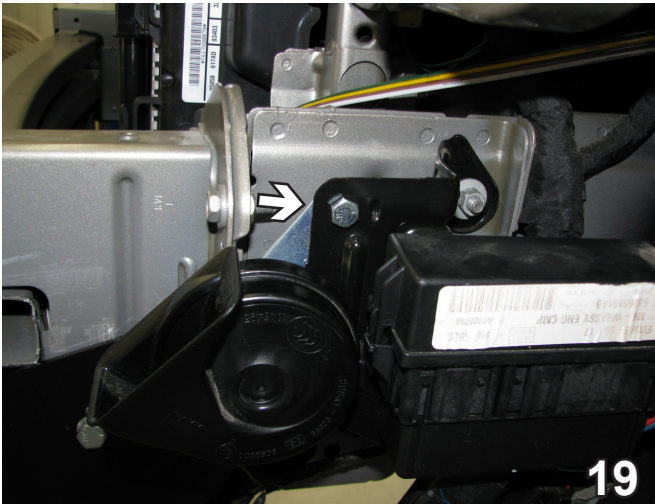

19. On the driver's side only, relocate the horn to on top of the frame with a 1/4-20 x 3/4" bolt and 1/4-20 whiz nut.



20. Zip tie the sensor to the bottom of the baseplate and reconnect.

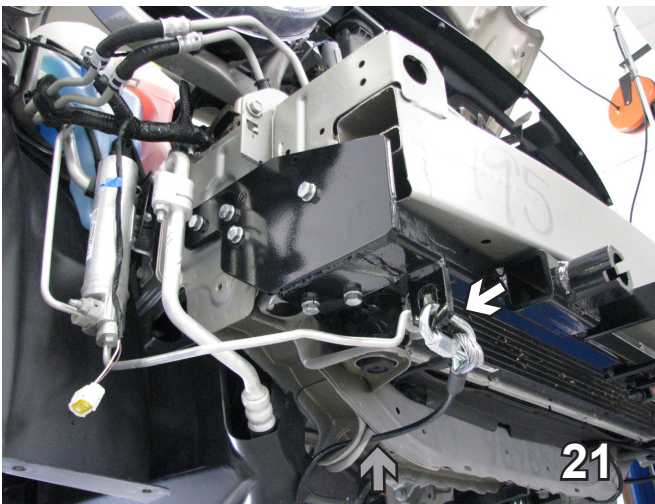

21. Attach the permanent baseplate safety cables to the provided convenience link on the baseplate (see right white arrow). The photo above shows the recommended installation of the cables to frame of vehicle (see grey arrow). Additional options may interfere with suggested mounting; in this case secure the cables to a solid piece of the frame as described in the instructions included with the permanent baseplate safety cables. Be sure the safety cables do not rub against any hoses or moving parts. Do this to both sides of the vehicle.

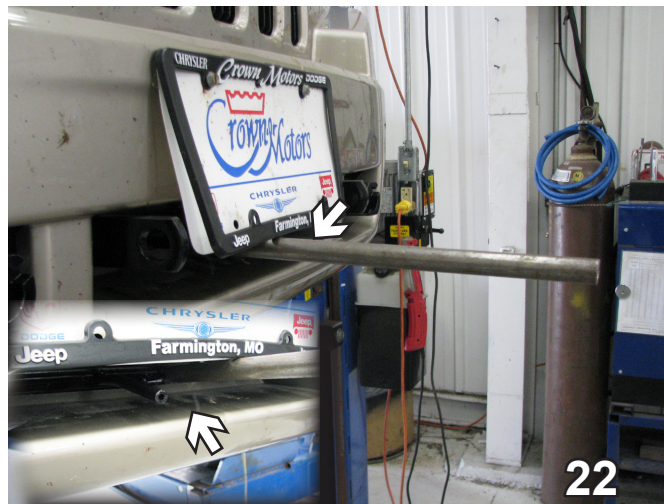

22. If the vehicle is equipped with a front license plate bracket which is in the way, insert a rod to pull it down.

Be sure that **ALL** electrical connections are plugged in properly and functioning **BEFORE** installing the fascia.

23. Reinstall the fascia, pushpins and bolts.

BX1129
2010 Jeep Compass
Installation Instructions

DEALER or INSTALLER:

Be certain the user receives the instruction sheets for their products.

CUSTOMER SERVICE COMMITMENT

Install the tow bar and safety cables according to the instructions provided in their packages. When demonstrating this to the customer, be sure to include all the contents and packages.

Do **NOT** substitute other devices if the tow bar pins and clips are misplaced.

Blue Ox is committed to providing you with exceptional customer care throughout your lifetime with our products. Our team is here to assist you with any questions you may have regarding the performance of your product. Simply call 1-(402) 385-3051 and you can speak with our customer care team.

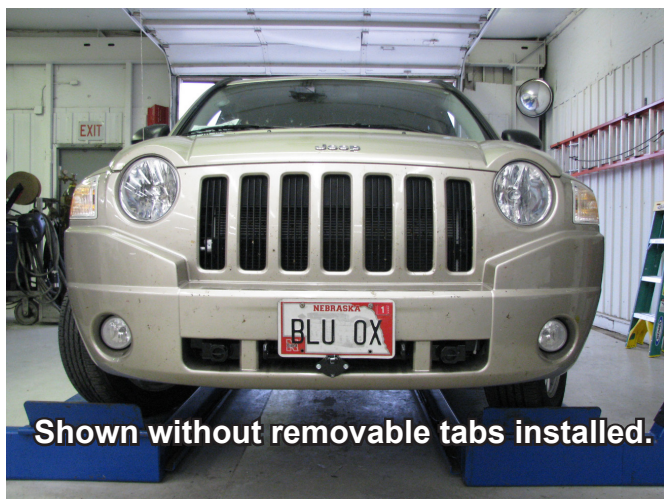

Additionally, please visit our website to see which rallies our Destination America team will be attending. For a nominal fee, our service technician will service your towing system to ensure it's in proper working condition. Also as a commitment to our customers, should you visit our factory you can stay at our full service Blue Ox campground at no charge along with enjoying a factory tour.

Again thank you for being our customer and for the confidence you have shown in the performance of our products. It is because of customers like you we enjoy the success we have today.

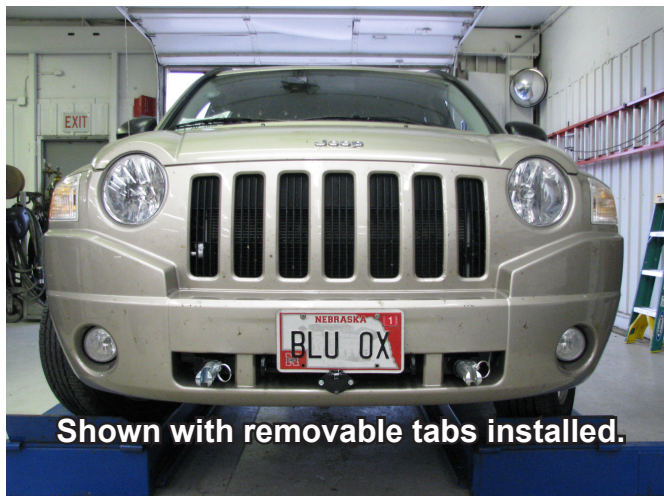

© 2010 Blue Ox
One Mill Road, Industrial Park
Pender, Nebraska 68047
Phone: (402) 385-3051 • Fax: (402) 385-3360
www.blueox.com