



Strong As An Ox™

BX1627 Installation Instructions

1998-01 Oldsmobile Bravada 4WD Smart Drive

1998-05 Chevrolet S-10 Blazer 4WD

Installation of this baseplate requires removing the plastic belly pan, tow hooks and the bumper molding. The threaded holes used to attach the belly pan will also be drilled out.

1. Lift the hood and pull the middle grill section out (snaps in and out). Remove the license plate to get access to the push pins and remove. Unplug the running lights. The bumper molding can now be pulled from the vehicle.
2. Remove the six bolts which hold the plastic belly pan to the frame, as well as the four bolts which attach the two tow hooks to the frame. Only the two back bolts that attach the belly pan will be used again. Notice that the front two inside sets of holes that are used to attach the belly pan are threaded.
4. Drill these four threaded holes out using a drill and 1/2" bit.
5. Insert the bolt plates (Items 2) inside of the frame tubing from the front of the vehicle. Insert the plates through the set of inside hole as shown in the diagram on page two.
6. Position the baseplate over the four bolts. Use "Loctite Red" with each bolt. Use the flat and lock washers and nuts with each bolt (Items 3, 5 and 6). Hand tighten only.
7. Using the 10MM-1.5 x 50MM hex bolts (Item 4) reattach the tow hooks to the vehicle frame in the same position as before. Be sure to include a lock washer and a flat washer against the head of the bolt. The bolts should pass through the outside holes on the baseplate end mounts, through the frame, and screw into the tow hook. Using the baseplate as a template, drill forward holes with the 7/16" drill bit. Install and tighten items 3, 4 and 5 on forward holes. Be sure and use Loctite Red on all bolts before tightening.
8. After all the hardware has been started, they may be fully tightened. The baseplate should fit firmly against the frame on both sides. Tighten the nuts and torque according to the chart in the General Instruction Sheet.
9. Replace the bumper molding on the vehicle. NOTE: (Blazers only) It is necessary to trim the inside portion of the opening where the tow hooks extend. Some models have a small hole already existing. Enlarge the area enough for the attachment tabs to clear. The belly pan may be reattached to the underside of the baseplate using the welded bolts. Place a flat washer over the four front holes on the top side of the belly pan. Position the pan over the bolts so that the four flat washers are below the four nuts used to secure the baseplate. Secure the belly pan using the four remaining flat washers, lock washers, and hex nuts, and the two original bolts. It is not necessary to use Loctite Red here.
10. The dimensional variations between otherwise identical cars can be considerable. While the location and size of the holes in the baseplate were designed to allow for easy installation, it may be necessary to file a hole slightly to allow a bolt to clear.

11. Install the tow bar and safety cables according to the instructions included in their packages.
12. Do not substitute other devices if the tow bar pin and clip are lost.
13. **DEALER OR INSTALLER: BE CERTAIN THE USER RECEIVES THE INSTRUCTION SHEET.**

Tools Required

17MM Socket 15MM Socket Drill
 1/2" Bit Loctite Red 6" Extension for Metric Sockets

Parts List

Ref. No.	Qty.	Part No.	Description
1	1	61-5246	Weldment, Baseplate, BX1627
2	2	61-4363	Bolt Plate
3	10	203-0104	10MM Lock Washer
4	6	201-0428	10MM-1.5 x 50MM Hex Bolt, Grade 8.8
5	6	202-0111	10MM Hex Nut
6	8	203-0103	10MM Flat Washer
	2	226-0046	Baseplate Safety Cable, 36" CL III (NS)
	4	229-0359	Quicklink, 3/8, ZP (Not Shown)

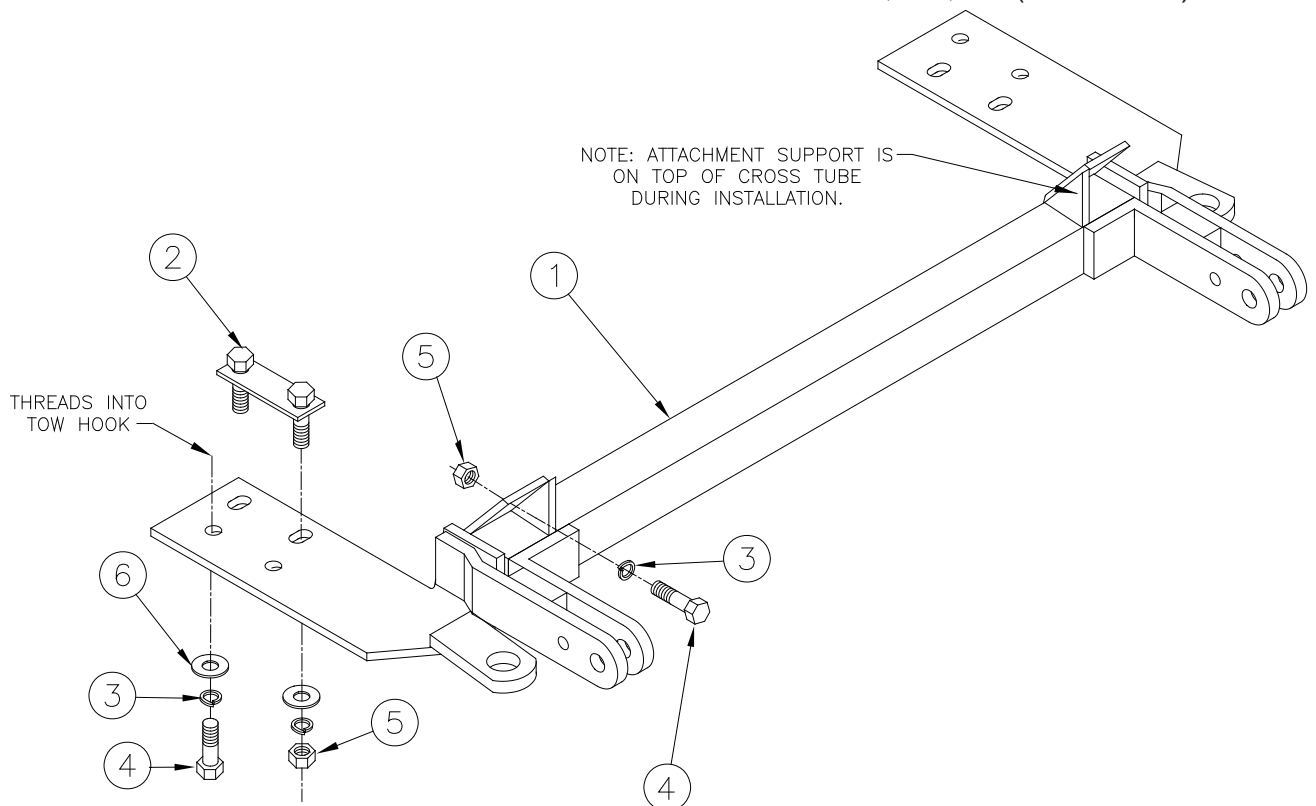

IMPORTANT: Use only genuine factory replacement parts on your Base Plate. Do not substitute homemade or non-typical parts. If a bolt is lost or in need of replacement, for your safety and the preservation of your Base Plate, be sure to use a replacement bolt of the same grade (Usually Grade 5, refer to parts list). Repair parts may be ordered through your nearest Blue Ox dealer or distributor. Failing to follow and/or altering these installation instructions in either installation or required equipment will void the manufacturer's warranty. Towing behind a non-motorized vehicle will void the warranty.