



BX1629 Installation Instructions
1999 Chevrolet Tracker (2&4 DR/2WD & 4WD)
1999 Suzuki Vitara (2 DR/ 4WD)

Serial Number

The baseplate mounts to the metal bumper and to the lower cross frame of the vehicle. Six holes need to be drilled for installation. The attachment tabs will extend through the grill opening approximately four inches.

1. Notice the four push pins on the top portion of the grill. Remove the push pins from the grill and gently pull the grill out of its holding position.
2. Notice the seven push pins on the top of the bumper molding. Remove the push pins. Remove the push pins or Phillip head screws in front of the drivers and passengers side front tires. Use a 10mm wrench or socket and remove the bolt on the drivers and passengers side in front of the tires. There are also bolts that need to be removed on the bottom side of the bumper fascia. Gently pull the bumper forward and off its holding position.
3. Remove the front inside bolts of the suspension bracket bolted to the lower cross frame.
4. Notice plastic wire loom on the passenger side on the inside of the frame is attached with a plastic clip, pull it out. On the opposite side is a similar hole, drill each hole out to 3/8".
5. Hold the baseplate up so the braces align with existing holes on the cross frame. Use the existing bolts and loosely fasten the baseplate. Use Loctite with each bolt.
6. Hold up the baseplate so the front bolt holes align with the existing holes on the frame. Use the 3/8" bolts into the existing holes. Notice the frame opening on the bumper on each side. Insert the nut plate and hand tighten the bolts into the nut plate. Once the two braces and the frame bolts are started, tighten and torque the bolts according to the specification chart in the General Instruction Sheet.
7. Drill out the extra holes through the frame with a 3/8" drill bit and use the same hardware as in the previous holes. Tighten and torque bolts.
8. Replace the bumper molding.
9. Install the tow bar and safety cables according to the instructions included in their packages. Do not substitute other devices if the tow bar pin and clip are lost.
10. **DEALER OR INSTALLER: BE CERTAIN THE USER RECEIVES THE INSTRUCTION SHEET.**

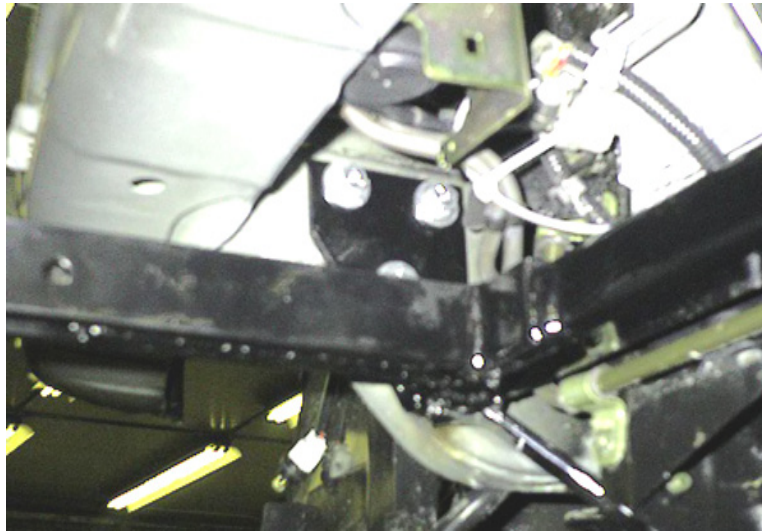

Automatic

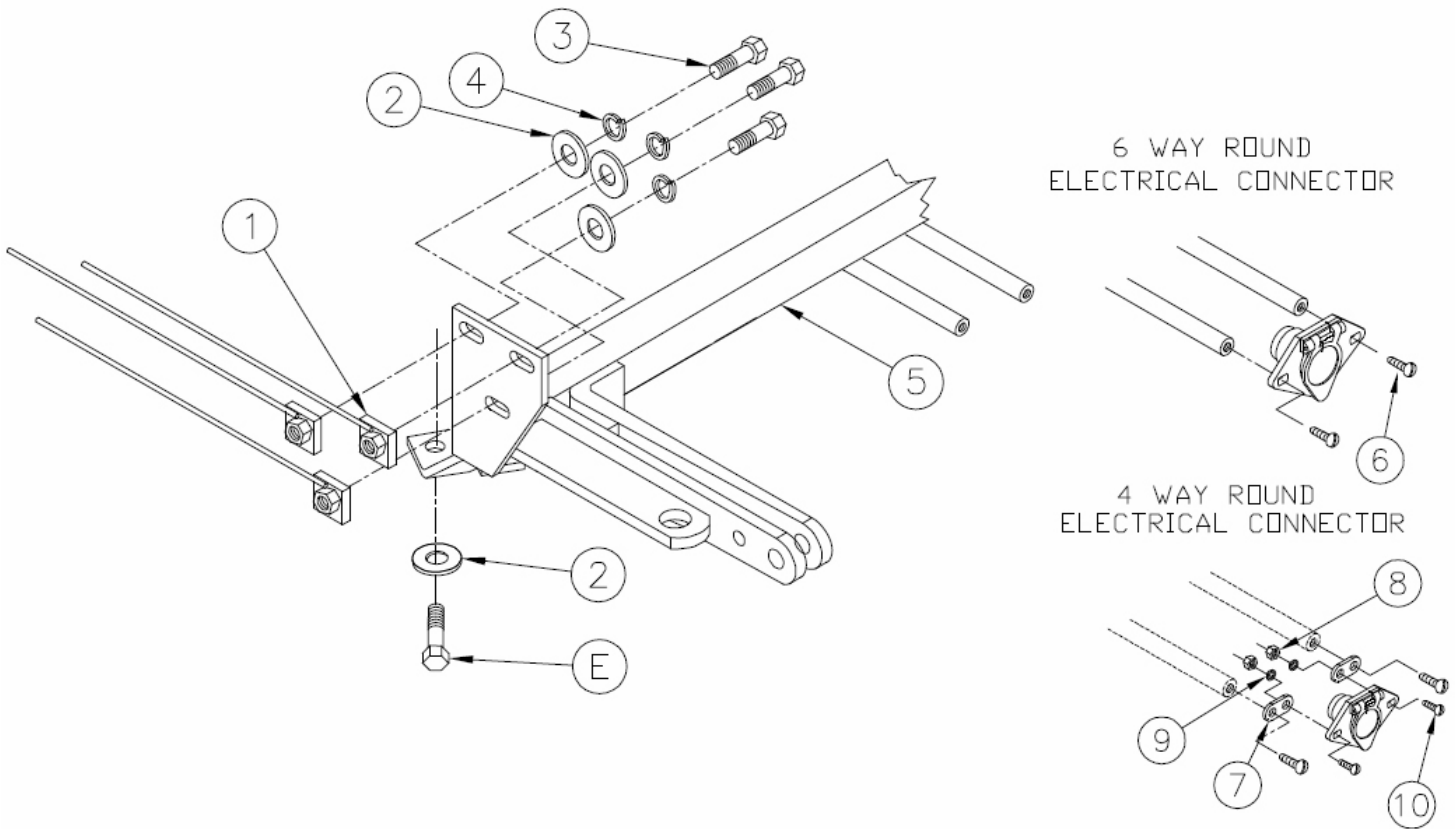

Tools Required

10MM Wrench
Hack Saw

Utility Knife
1/2" Drill Bit

Loctite
Drill

3/4" Wrench
18MM Wrench

Parts List

Ref. No.	Qty.	Part No.	Description
1	6	61-5208	3/8 Nut Plate 1/4 x 1 x 1 with Wire
2	8	203-0003	3/8 Flat Washer, ZP
3	6	201-0368	3/8-16 x 1 1/4 Hex Bolt, Grade 5
4	8	203-0010	3/8 Lock Washer
5	1	61-5294	Baseplate, BX1629
6	2	201-0979	#12-14 x 1" Self Drilling Screw, ZP
7	2	101-5822	Adapter, 4 way Connector
8	2	202-0047	#10-32 Hex Nut
9	2	203-0054	#10 Lock washer
10	2	201-0192	#10-32 x 1/2 Slot, Rd. Hd Screw
	2	226-0046	Baseplate Safety Cable, 36" CL III (Not Shown)
	4	229-0359	Quicklink, 3/8, ZP (Not Shown)