



Strong As An Ox™

BX1643 Installation Instructions

Serial No.

2001-05 Chevy Venture

3.4 L / V-6

The front fascia, metal bumper, and head lights are removed for baseplate installation. Holes need to be drilled and there is trimming to the front fascia. The attachment tabs are 24 inches center to center and 13 1/2 inches height.



1. Remove one bolt from head light assembly, pull forward, disconnect all electrical components, and set aside, both sides.



2. Remove one phillips head push pin from under head light assembly, each side.



3. Just forward of front tires in wheel well are two push pins to be removed, each side.



4. Just forward of front tires under fascia corners are two push pins to be removed, each side.



5. Remove the four push pins from front fascia openings pull fascia forward and set aside. Then remove air dam from bottom of metal bumper, there are four push pins, and set aside.



6. Using item 4 as a template, drill a 13/32" hole on the out side of frame end, each side. Horn brace may need to be bent out of the way on both sides.



Strong As An Ox™

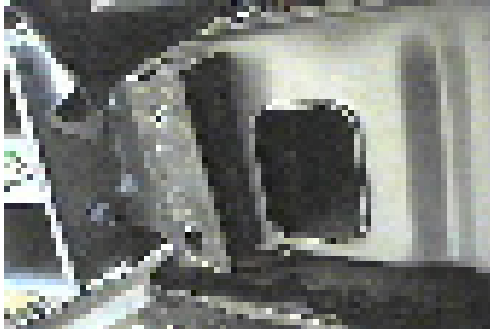

8. Insert item 2 into side frame openings to drilled and existing holes, through 4 of item 4 each side, and into item 1.



9. Hold baseplate into place and bend frame webbing out of the way just under metal bumper.

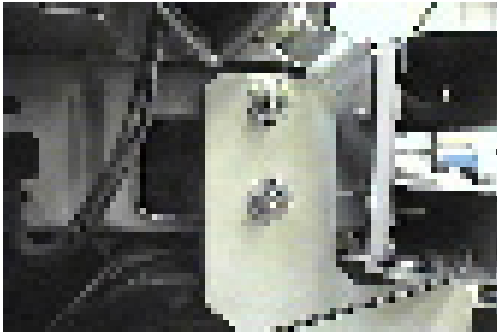

10. Use items 5, 6, and 7 to fasten baseplate to frame. Do not tighten. **Be sure and use loctite on all bolts before tightening.**



11. Hold item 1 to the bottom of metal bumper and drill four 13/32" holes. Insert item 3 into metal bumper ends to drilled holes. Using items 6 and 7 tighten. Then tighten remaining bolts. **Be sure and use loctite on all bolts.**

12. Some trimming is required to air dam to bottom of metal bumper before replacing. Use 2 self tapping screws to help hold air dam in place, item 8. Be sure all bolts are tightened according to manufacturer specifications.

13. Replace Fascia and head light assemblies.

14. The dimensional variations between otherwise identical cars can be considerable. While the location and size of the holes in the baseplate were designed to allow for easy installation. It may be necessary to file a hole slightly.

15. Install tow bar and safety cables according to the instructions included in their packages. Do not substitute other devices if the tow bar pin or clip is lost.

16. **DEALER OR INSTALLER: BE CERTAIN THE USER RECEIVES THE INSTRUCTION SHEET.**



Tools Required

Loctite Blue

17/32" Drill Bit
Vise Grips

9/16" Socket

Parts List

Ref. No.	Qty.	Part No.	Description
1	1	61-5637	Weldment, Base Plate, BX1643
2	4	61-5610	Weldment, 3/8-16 X 2 1/4, Nut Plate
3	4	61-5609	Weldment, 3/8-16 x1 1/4, Bolt Plate, with Wire
4	8	102-6080	Plate, Spacer, BX3221
5	4	203-0003	3/8 Flat Washer, ZP
6	8	203-0010	3/8 Lock Washer, ZP
7	8	202-0003	3/8-16 Hex Nut, ZP
8	4	201-0979	#12-14 x 1" Self Drilling Screw, ZP
9	2	202-0047	#10-32 Hex Nut
10	2	203-0054	#10 Lock Washer
11	2	201-0192	#10-32 x 1/2 Slot, Rd. Hd. Screw
12	2	101-5822	Adapter, 4 Way Connector

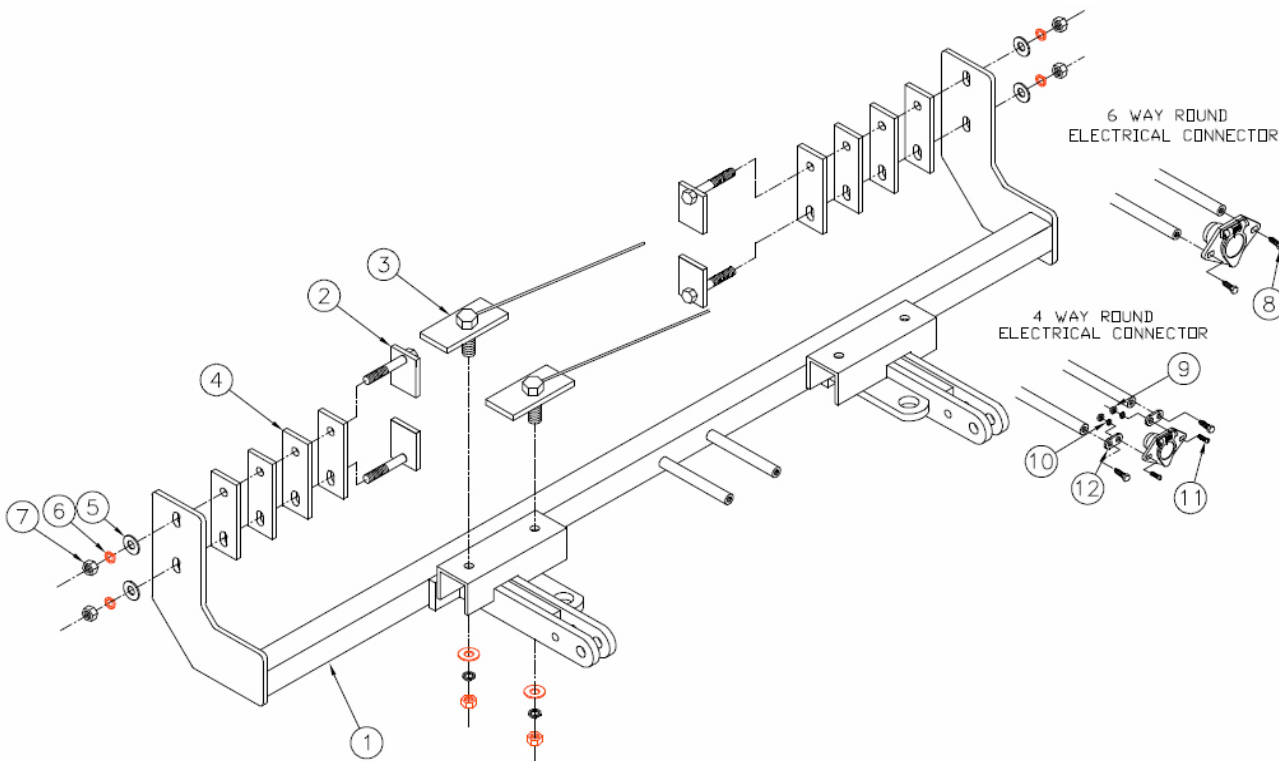

IMPORTANT: Use only genuine factory replacement parts on your Base Plate. Do not substitute homemade or nontypical parts. If a bolt is lost or in need of replacement, for your safety and the preservation of your Base Plate, be sure to use a replacement bolt of the same grade (Usually Grade 5, refer to parts list). Repair parts may be ordered through your nearest **Blue Ox** dealer or distributor.