



Strong As An Ox™

### BX1663 Installation Instructions 2005 - 08 Chevy Uplander

Serial No.

The front fascia, horn brackets and lower air dam are removed for baseplate installation. Drilling is required. Trimming of air dam is required. The BX8869 is available for the vehicle. Attachment Tabs are 24 inches center to center and a height of 14 1/2 inches.



1. Remove the five push pins from the top edge of fascia.



2. Just forward of front tire, on the edge of wheel well are three phillips head screws to remove with the phillips screw driver, both sides.



3. Just forward of front tire, on the lower edge of fascia are two phillips head screws to remove with the phillips screw driver, both sides.



4. Pull driver's side wheel well cover away from fascia edge, just forward of front tires, remove the metric hex nut (white arrow) and loosen the two metric hex nuts (black arrow) with the 10MM socket, both sides.

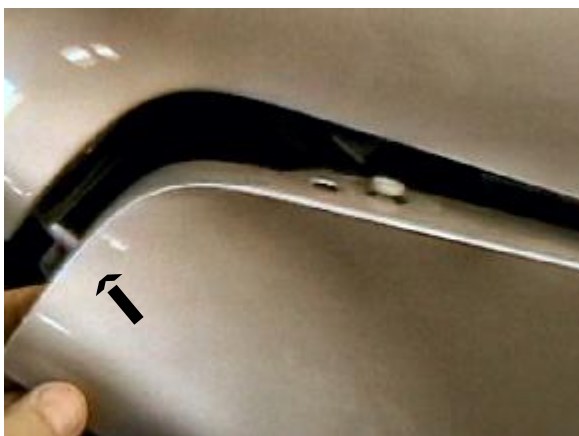

5. Pull fascia's outer corner forward to release back pin and then down to release upper tabs. Unplug the electrical connections from the driving lights, both sides and set fascia aside (passenger side shown).



Strong As An Ox™



6. Using the utility knife, cut and remove the cupped portion of air dam, both sides (left photo). Cut and remove upper portion of air dam just below metal bumper, both sides, to open area for baseplate installation.



7. Remove metric bolt from horn bracket using the 13MM socket, unplug the horn and set aside, both sides (white arrow).

8. Just below radiator are four metric bolts to remove on lower air dam with the 10MM socket, set aside.



9. Align front hole of base plate with lower existing hole in frame as shown step 7 (black arrow), both sides. Insert nut plate into opening on top side of frame to align with lower existing hole inside frame, hand tighten 3/8-16 hex bolt and lock washer with the 9/16" socket, both sides. **Be sure to use loctite red on all bolts before tightening. Tighten all bolts according to Torque Chart in General Instruction Sheet.**

10. Using the baseplate as a template drill two holes in the bottom side of frame with the 13/32" drill bit. Insert nut plate into opening on top side of frame to align with lower drilled holes inside frame, tighten 3/8-16 hex bolts and lock washers with the 9/16" socket, both sides. Tighten bolts in step 9, both sides. **Be sure to use loctite red on all bolts before tightening. Tighten all bolts according to Torque Chart in General Instruction Sheet.**



Strong As An Ox™



11. Using the baseplate as a template drill two remaining holes with the 13/32" drill bit, both sides. Insert nut plate into opening of frame to align with drilled hole, tighten 3/8-16 hex bolts and lock washers, both sides. **Be sure to use loctite red on all bolts before tightening. Tighten all bolts according to Torque Chart in General Instruction Sheet.**



12. Reinstall horn brackets, lower air dam and fascia. **Be sure that all electrical connections are plugged in properly before installing fascia.**

13. The dimensional variations between otherwise identical cars can be considerable. While the baseplate was designed for easy installation, it may be necessary to tailor the baseplate slightly to compensate for auto manufacturers' tolerances. These minor adjustments may include filing a hole slightly, bending electrical rods, adding shims and/or bending endplates.

14. Install the tow bar and safety cables according to the instructions included in their packages.

15. Do **not** substitute other devices if the tow bar pin and clip are lost.

16. **DEALER OR INSTALLER: BE CERTAIN THE USER RECEIVES THE INSTRUCTION SHEET.**





Strong As An Ox™

## Tools Required

10MM Socket  
Phillips Screw Driver  
Utility Knife

13MM Socket  
Loctite Red

9/16" Socket  
Vise Grip

## Parts List

Ref. No.	Qty.	Part No.	Description
1	1	61-6129	Weldment, Base Plate, BX1663
2	10	61-5208	Weldment, 3/8" Nut Plate, w/ 14" Wire
3	10	201-0368	3/8-16 x 1 1/4 Hex Bolt, Grd. 5, ZP
4	10	203-0010	3/8" Lock Washer, ZP
5	2	201-0553	1/4-20 x 1/2 Hx. Wshd, Type F Screw
6	2	201-0192	#10-32 x 1/2 Slot, Rd. Hd. Screw
7	2	203-0054	#10 Lock Washer
8	2	202-0047	#10-32 Hex Nut
9	2	101-5822	Adapter, 4 Way Connector
10	2	62-3468	Attachment, Assembly, SF/ SB (R)
	2	226-0046	Baseplate Safety Cable, 36" CL III (Not Shown)
	2	229-0359	Quicklink, 3/8, ZP (Not Shown)
	2	290-0437	Receiver, Cap Plug (BLK) (Not Shown)



*Location for the Bx8869 on driver's side tail light assembly.*

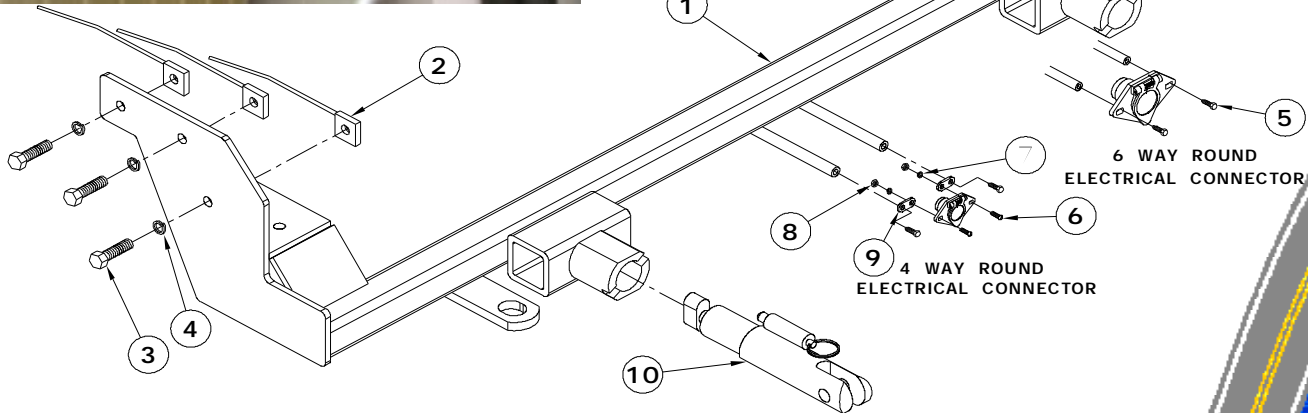
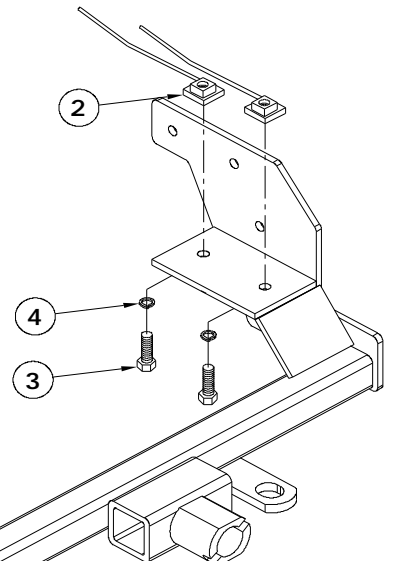

**IMPORTANT:** Use only genuine factory replacement parts on your Base Plate. Do not substitute homemade or nontypical parts. If a bolt is lost or in need of replacement, for your safety and the preservation of your Base Plate, be sure to use a replacement bolt of the same grade (Usually Grade 5, refer to parts list). Repair parts may be ordered through your nearest **Blue Ox** dealer or distributor.

