



# BLUE OX<sup>®</sup>

## Baseplate Installation Instructions

### BX1681

2007-13 Chevy Pickup 1500, 2500 & 3500

New Style Heavy Duty (2WD/4WD), 2007-11  
GMC Pickup 2500 & 3500 New Style, 2008-10

GMC Yukon 2500

### Installation Instructions

Serial Number

Please read BOTH these Installation Instructions and the General Towing Instructions before attempting to install or operate this equipment.

- Blue Ox<sup>®</sup> towing products and accessories are intended to be installed by Blue Ox<sup>®</sup> Dealers who are familiar with our products and have the equipment and knowledge to do "fit work." When necessary, Blue Ox<sup>®</sup> Dealers can be found at [www.blueox.com](http://www.blueox.com) or by contacting our Customer Care Department at (402) 385-3051.
- Many Blue Ox<sup>®</sup> Baseplates are designed to use existing holes and hardware to mount the baseplate to the towed vehicle. Even though bolts are there, do not assume they are adequate for baseplate mounting. Always use hardware supplied in the hardware kit or existing hardware specified in the Baseplate Towing Installation Instructions.

Attachment Tab Height: 16"

Attachment Tab Width: 32"

#### Bolt Torque Specifications

Torque in Foot-Pounds for Metric Bolts

Bolt Size	Grade 8.8	Grade 10.9
6MM	6	8
8MM	16	22
10MM	31	40
12MM	54	70
14MM	89	117

Confirm the towability and pre-towing procedures for your vehicle with the owner's manual or contact the vehicle's manufacturer for specific towing procedures.

#### Bolt Torque Specifications

Torque in Foot-Pounds for Inch Bolts

Bolt Size	Grade 5	Grade 8
1/4"	10	14
5/16"	19	29
3/8"	33	47
7/16"	54	78
1/2"	78	119
5/8"	154	230



If the front of your vehicle looks different than this, call us at (402) 385-3051.

## ! WARNING

Failure to read and follow these instructions could result in separation of the towed vehicle from the tow bar, causing property damage, loss of towed vehicle, personal injury or death.

# BX1681

## 2007-13 Chevy Pickup 1500, 2500 & 3500 New Style Heavy Duty (2WD/4WD), 2007-11 GMC Pickup 2500 & 3500 New Style, 2008-10 GMC Yukon 2500

### Installation Instructions

## Parts List

Ref. No.	Qty.	Part #	Description
1	1	61-6525	Weldment, Baseplate, DS, BX1681
2	1	61-6526	Weldment, Baseplate, PS, BX1681
3	8	201-0011	1/2-13 X 1 1/4" Hex Bolt Grd.5, ZP
4	8	203-0012	1/2" Lock Washer, ZP
5	1	101-6135	Bracket Electrical, 90 Degree
6	4	201-0050	1/4-20 X 3/4" Hex Bolt Grd.5, ZP
7	4	203-0008	1/4" Lock Washer, ZP
8	2	203-0001	1/4" Flat Washer, ZP
9	4	202-0069	1/4-20 Hex Flange Whiz Lock Nut, ZP
10	2	201-0192	10-32 X 1/2" Slot, RD. HD. Screw
11	2	203-0054	#10 Lock Washer
12	2	202-0047	#10-32 Hex Nut
13	2	101-5822	Adapter, 4 Way Connector
14	2	62-3468	Attachment Tab Assembly, Removable, SF/SB, 1 Hole
	2	226-0049	Permanent Baseplate Safety Cable 36" CL IV (Not Shown)
	2	229-0512	Quicklink, 1/2", ZP (Not Shown)
	2	290-0437	Receiver, Cap Plug (Black) (Not Shown)

### Tools Required

Loctite® RED  
 18MM Socket  
 3/4" Socket  
 18MM Wrench  
 1/4" Wrench  
 11/16" Wrench  
 Flat Screw Driver  
 Utility Knife

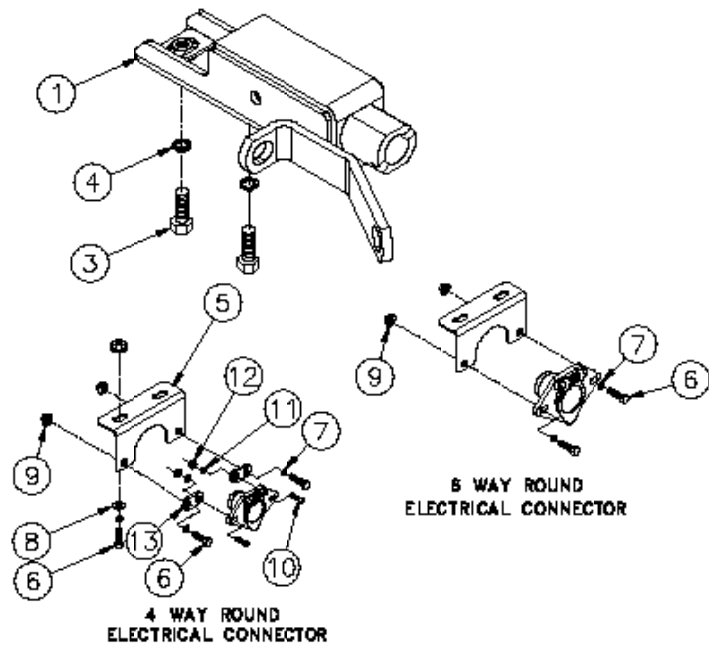
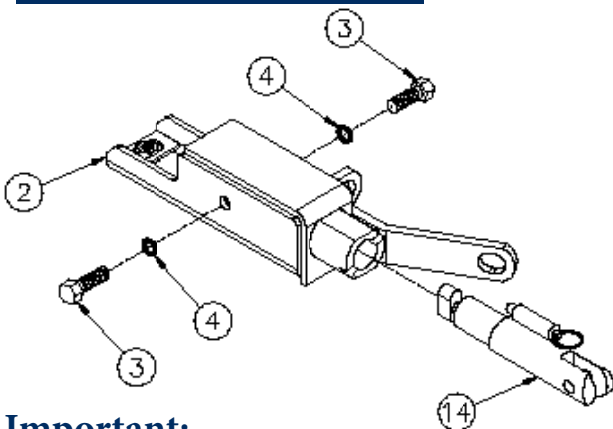

### Important:

Use only genuine factory replacement parts on your baseplate. Do **NOT** substitute homemade or non-typical parts. If a bolt is lost or in need of replacement, for your safety and the preservation of your baseplate, be sure to use a replacement bolt of the same grade (In most cases it will be Grade 5, please reference the parts list above). Replacement parts may be ordered through your nearest Blue Ox® Dealer or Distributor. Failing to follow and/or altering these installation instructions in either installation or required equipment will void the manufacturer's warranty. Towing behind a non-motorized vehicle will void the warranty.

BX1681  
2007-13 Chevy Pickup 1500, 2500 & 3500 New Style Heavy  
Duty (2WD/4WD), 2007-11 GMC Pickup 2500 & 3500 New  
Style, 2008-10 GMC Yukon 2500  
Installation Instructions

### Vehicle Weight:

The weight of this vehicle is near the Class III, 5,000 lbs. rating limitations. Some models, depending on options, may well exceed this 5,000 lb. rating. Be sure to confirm the weight of your individual vehicle before towing. As of 1999 the Aventa® II is now rated 10,000 lbs. and either the Aventa® II or the Aventa® LX tow bar must be used for these applications.

**Tow Bar Adapters are NOT to be used with vehicles weighing over 5,000 lbs.**

**Installation Notes:** The tow hooks are removed during the baseplate installation. Trimming of the fascia is required. The tow hooks will not be reinstalled.

The dimensional variations between otherwise identical vehicles can be considerable. While the baseplate was designed for easy installation, it may be necessary to tailor the baseplate slightly to compensate for auto manufacturer's tolerances. These minor adjustments may include filing a hole slightly, bending electrical rods or bending end plates.

The BX8869 Bulb & Socket Wiring Kit is recommended.

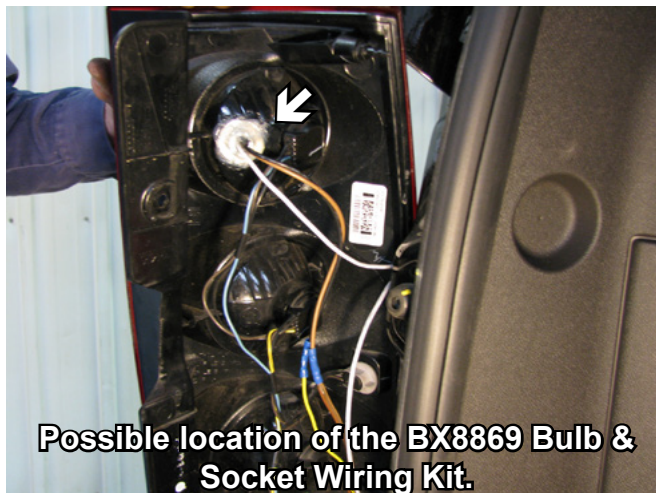

### Installation Instructions:



1. Using the 18MM socket, go up in behind to remove the bottom two metric bolts from the tow hook. Do this to both sides of the vehicle. Pull the tow hook forward and set aside. **The tow hooks will not be reinstalled.**

Handling of some cosmetic parts when installing this product may require the use of protective covers, rags, specialty tools, etc. to prevent damage.



## BX1681

2007-13 Chevy Pickup 1500, 2500 & 3500 New Style Heavy Duty (2WD/4WD), 2007-11 GMC Pickup 2500 & 3500 New Style, 2008-10 GMC Yukon 2500

### Installation Instructions



#### 2A. CREW CABS:

Using a utility knife, cut out around the tow hook opening to the lip on the inside to make the opening larger. Round the corners to prevent cracking. Do this on both sides.

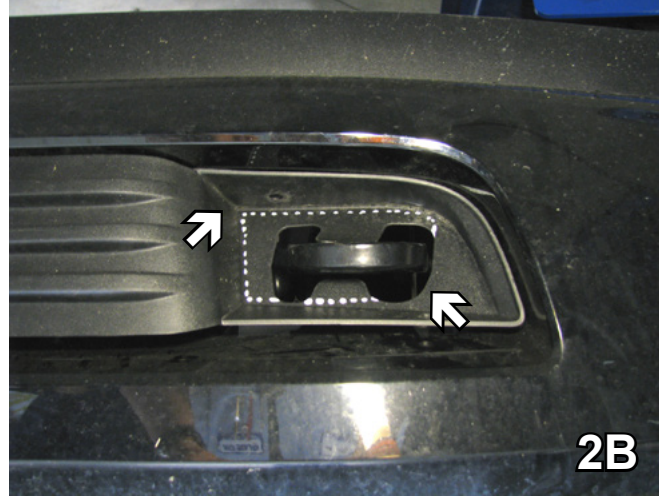

#### 2B. 2008 GMC YUKON XL 2500:

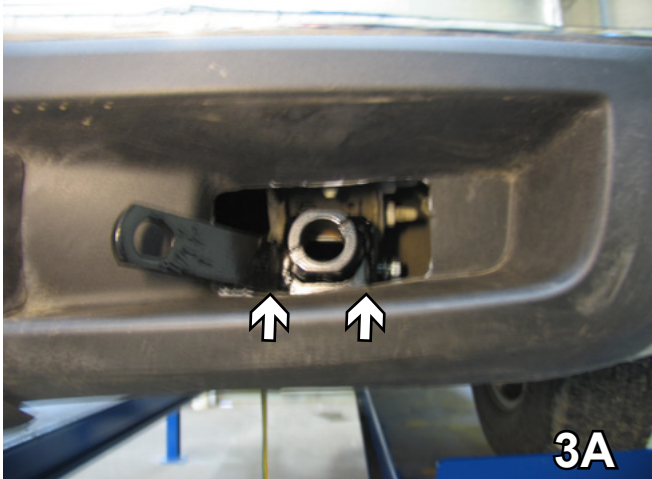

#### 3A. CREW CABS:

Slide the baseplate into the frame end to align with the existing tow hook holes on the frame rail. Push down on the plastic if necessary. Do this on both sides.



#### 3B. 2008 GMC YUKON XL 2500:

# BX1681

2007-13 Chevy Pickup 1500, 2500 & 3500 New Style Heavy Duty (2WD/4WD), 2007-11 GMC Pickup 2500 & 3500 New Style, 2008-10 GMC Yukon 2500

## Installation Instructions

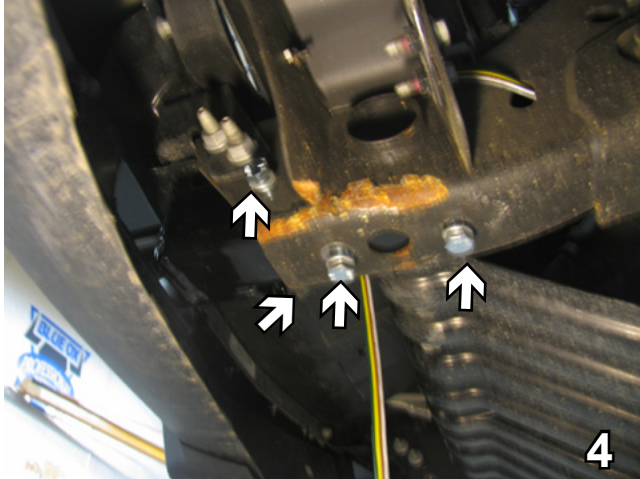

4. Start all four bolts, remount any hole if necessary as every vehicle is different. Insert 1/2 x 1 1/4" hex bolts with 1/2" lock washers. Be sure to use Loctite Red on all bolts. Do this on both sides.

**BE SURE TO USE LOCTITE® RED ON ALL BOLTS BEFORE TIGHTENING. TIGHTEN ALL BOLTS ACCORDING TO THE TORQUE CHART ON THE FRONT PAGE OF THESE INSTRUCTIONS OR ON PAGE 3 OF THE BASEPLATE TOWING GENERAL INSTRUCTIONS.**

Be sure that **ALL** electrical connections are plugged in properly and functioning **BEFORE** installing the fascia.

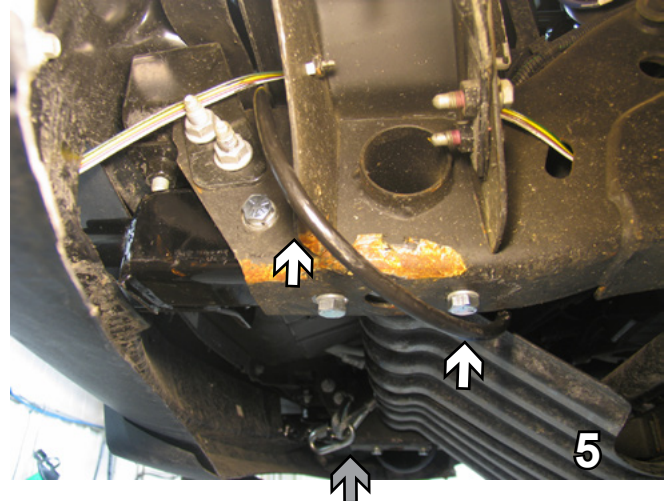

5. Attach the permanent baseplate safety cables to the provided convenience link on the baseplate (see grey arrow). The photo above shows the recommended installation of the cables to frame of vehicle (see white arrow). Additional options may interfere with suggested mounting; in this case secure the cables to a solid piece of the frame as described in the instructions included with the permanent baseplate safety cables. Be sure the safety cables do not rub against any hoses or moving parts. Do this to both sides of the vehicle.

**DEALER or INSTALLER:**  
Be certain the user receives the instruction sheets for their products.

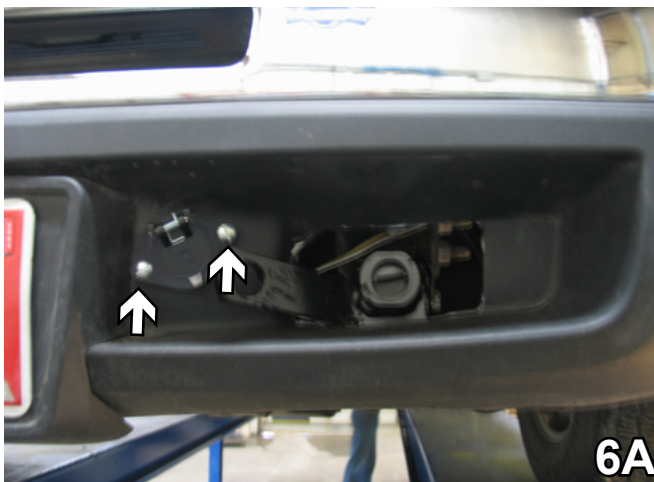

**6A. CREW CABS:**

Install electrical connector, using 1/4 x 3/4" hex bolts with 1/4" lock washers and 1/4" whiz nuts.

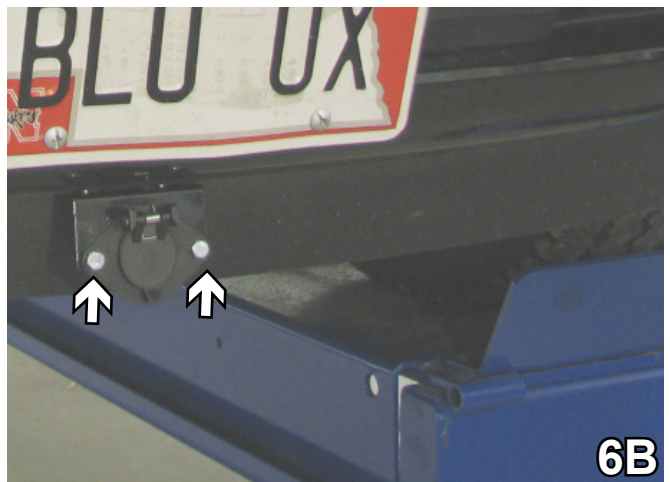

**6B. 2008 GMC YUKON XL 2500:**



## BX1681

2007-13 Chevy Pickup 1500, 2500 & 3500 New Style Heavy Duty (2WD/4WD), 2007-11 GMC Pickup 2500 & 3500 New Style, 2008-10 GMC Yukon 2500

### Installation Instructions

Install the tow bar and safety cables according to the instructions provided in their packages. When demonstrating this to the customer, be sure to include all the contents and packages.

Do **NOT** substitute other devices if the tow bar pins and clips are misplaced.



### CUSTOMER SERVICE COMMITMENT

Blue Ox is committed to providing you with exceptional customer care throughout your lifetime with our products. Our team is here to assist you with any questions you may have regarding the performance of your product. Simply call (402) 385-3051 and you can speak with our customer care team.

Additionally, please visit our website to see which rallies our Destination America team will be attending. For a nominal fee, our service technician will service your towing system to ensure it's in proper working condition. Also as a commitment to our customers, should you visit our factory you can stay at our full service Blue Ox campground at no charge along with enjoying a factory tour.

Again thank you for being our customer and for the confidence you have shown in the performance of our products. It is because of customers like you we enjoy the success we have today.

If the baseplate is in an accident, it must be replaced. DO NOT use it again! An accident can cause unseen damage and using it again could result in more damage or serious injury. DO NOT use the baseplate if it is damaged or missing parts.



© 2007, 08, 09, 10 Blue Ox  
One Mill Road, Industrial Park  
Pender, Nebraska 68047  
Phone: (402) 385-3051 • Fax: (402) 385-3360  
[www.blueox.com](http://www.blueox.com)