

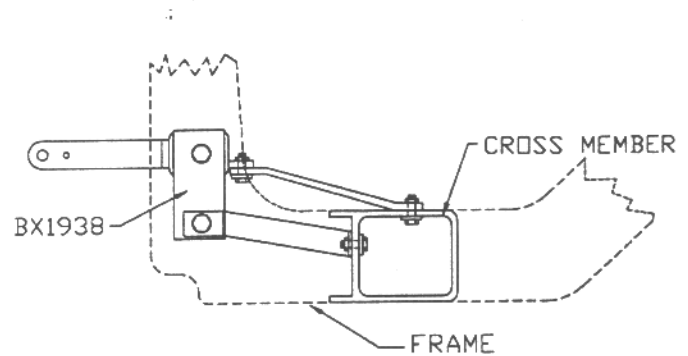

## BX1938 Installation Instructions 1999 Dodge Ram 1500 Sport

The bumper and rock guard are removed to install the baseplate. The attachment tabs extend through the grill approximately four inches.

1. Remove the flexible rock guard from the bottom of the truck by removing the torque bolts from the back side.
2. Remove the bumper by removing the nuts from the backside of bumper with a 18mm wrench, there are two on each side of the bumper. Be sure to disconnect the lights before removing the bumper.
3. Slide the main weldment (Item 1) between bumper brackets that extends up. Use existing holes. Insert the spacer (Item 5) on each side, using the 1/2 x 1 3/4 hex bolts, and lock washers (Items 7 and 10), loosely bolt the weldment to the brackets. Be sure to use Loctite on all bolts.
4. Bolt the center braces (Items 4) to the main weldment with the 1/2 x 1 3/4 hex bolts, lock washers, and hex nuts (Items 7, 8, 9 and 10). Use the bolt plates, lock and flat washers (Items 6, 8, 9 and 10), and hex nuts to bolt the other end to the cross member.



The dimensional variations between otherwise identical cars can be considerable. While the location and size of the holes in the baseplate were designed to allow for easy installation, it may be necessary to file a hole slightly to allow a bolt to clear.

5. Bolt the side braces (Items 2 and 3) to the main weldment with the 1/2 x 1 3/4 bolts, flat and lock washers, and hex nuts (Items 7, 8 and 10) notice there is a passenger's side and drivers's side brace. Bolt the other end of the brace to the face of the cross member with the bolt plates using Items 6, 8 and 10. Again go through the big hole in the cross member with the bolt plates.
6. Once all bolts have been started tighten and torque according to the torque charts in the General Instruction Sheet. Replace the bumper and rock guard.
7. Install the tow bar and safety cables according to the instructions included in their packages. Do not substitute other devices if the tow bar pin and clip are lost.
8. **DEALER OR INSTALLER: BE CERTAIN THE USER RECEIVES THE INSTRUCTION SHEET.**

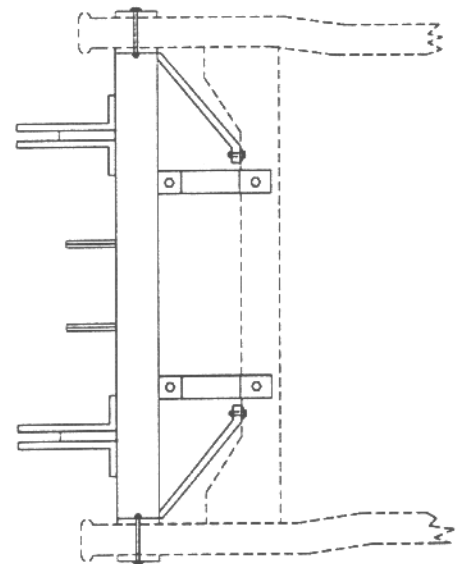

# Automatic

## Tools Required

3/4 Wrench

Torque Wrench

Loctite

18MM Wrench

## Parts List

Ref. No.	Qty.	Part No.	Description
1	1	61-5279	Baseplate, BX1938
2	1	102-5632	Side Brace, DS
3	1	102-5631	Side Brace, PS
4	2	102-5633	Center Brace
5	2	102-5629	Flat, Side Bracket
6	4	61-5286	Wldm't, Boltplate
7	6	201-0068	1/2-13 x 1 3/4 Hex Bolt
8	8	202-0005	1/2-13 Hex Nut
9	4	203-0005	1/2 Flat Washer
10	10	203-0012	1/2 Lockwasher

