



Strong As An Ox™

BX1966 Installation Instructions
2001-2003 Dodge Ram Van 1500/ 2500/3500

Serial No.

The metal bumper and bumper brackets are removed for baseplate installation. Drilling is required. Trimming of air dam on metal bumper is required. Bumper brackets are **not** reinstalled. The BX8869 is available for the vehicle. Attachment Tabs are 24 inches center to center and a height of 21 1/2 inches.

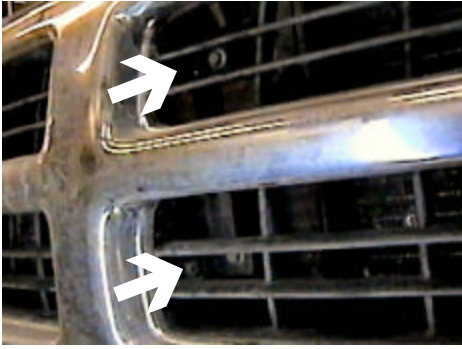

1. Remove two phillips head screws from behind grill center.

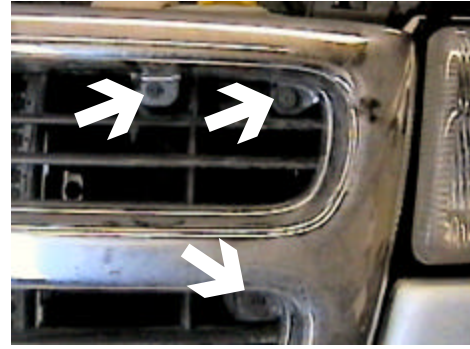

2. Remove three phillips head screws from grill, both sides and set grill aside.

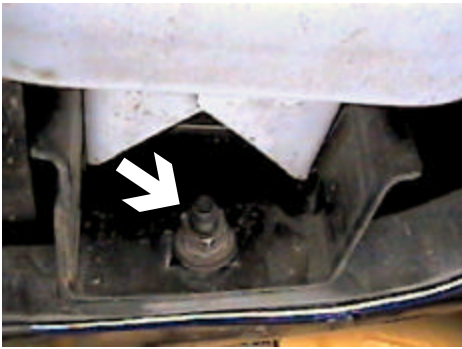

3. Remove metric bolt just behind lower edge of metal bumper with the 19MM socket, both sides.



4. Just forward of front tire is one metric bolt to remove from metal bumper bracket using the 19MM socket, both sides.



5. Using the 19MM socket, remove two metric bolts from the back side of metal bumper, just behind grill area, pull bumper forward and set aside.



6. Remove two plastic inserts from metal bumper.



Strong As An Ox™

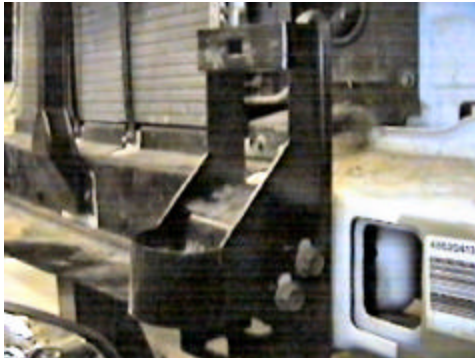

7. Using the 3/4" socket, remove the four metric bolts from bumper bracket, both sides and set aside. **Bumper bracket will not be reinstalled.**

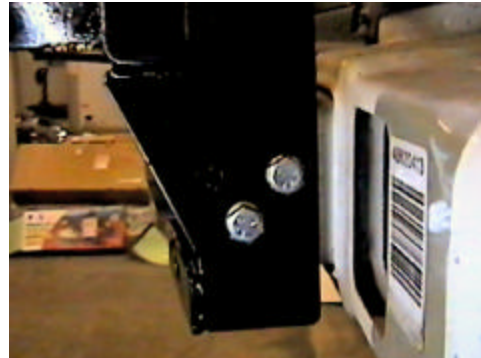

8. Slide baseplate over frame ends and align baseplate holes with bumper bracket mount location. Install 1/2 x 1 3/4" hex bolts, flat and lock washers as shown in drawing on page 3, while maintaining a level position with the baseplate. **Be sure and use loctite on all bolts before tightening. Torque all bolts according to torque chart in General Instructions.**



9. Using the baseplate as a template, drill hole on the top side of frame with the 17/32" drill bit, both sides. Insert 1/2 x 1 1/4" hex bolt and lock washer into drilled hole and tighten 1/2" whiz nut, both sides. **Be sure and use loctite on all bolts before tightening. Torque all bolts according to torque chart in General Instructions.**

10. Reinstall metal bumper. Hold plastic insert to align with bumper opening, trim as needed and reinstall, both sides.

11. The dimensional variations between otherwise identical cars can be considerable. While the location and size of the holes in the baseplate were designed to allow for easy installation, it may be necessary to file a hole slightly to allow a bolt to clear.

12. Install the tow bar and safety cables according to the instructions included in their packages.

13. Do **not** substitute other devices if the tow bar pin and clip are lost.

14. **DEALER OR INSTALLER: BE CERTAIN THE USER RECEIVES THE INSTRUCTION SHEET.**



Tools Required

19MM Socket
Utility Knife

3/4" Socket
Loctite

17/32" Drill Bit
Phillips Screw Driver

Parts List

Ref. No.	Qty.	Part No.	Description
1	1	61-5989	Weldment, Base Plate, BX1966
2	1	101-6135	Electrical, Bracket, BX2160
3	2	61-4029	1/2-13 Whiz Nut, w/ 10" Wire
4	2	202-0011	1/2-13 x 1 1/4 Hex Bolt, Grd. 5, ZP
5	8	202-0068	1/2-13 x 1 3/4 Hex Bolt, Grd. 5, ZP
6	10	203-0012	1/2 Lock Washer, ZP
7	4	203-0005	1/2 Flat Washer, ZP
8	4	201-0569	1/4-20 x 3/4 Hex Bolt, Grd. 5, ZP
9	4	203-0008	1/4 Lock Washer, ZP
10	2	203-0001	1/4 Flat Washer, ZP
11	4	202-0069	1/4-20 Hex Whiz Nut, LocZP
12	2	201-0192	#10-32 x 1/2 Slot, Rd. Hd. Screw
13	2	203-0054	#10 Lock Washer
14	2	202-0047	#10-32 Hex Nut
15	2	101-5822	Adapter, 4 Way Connector

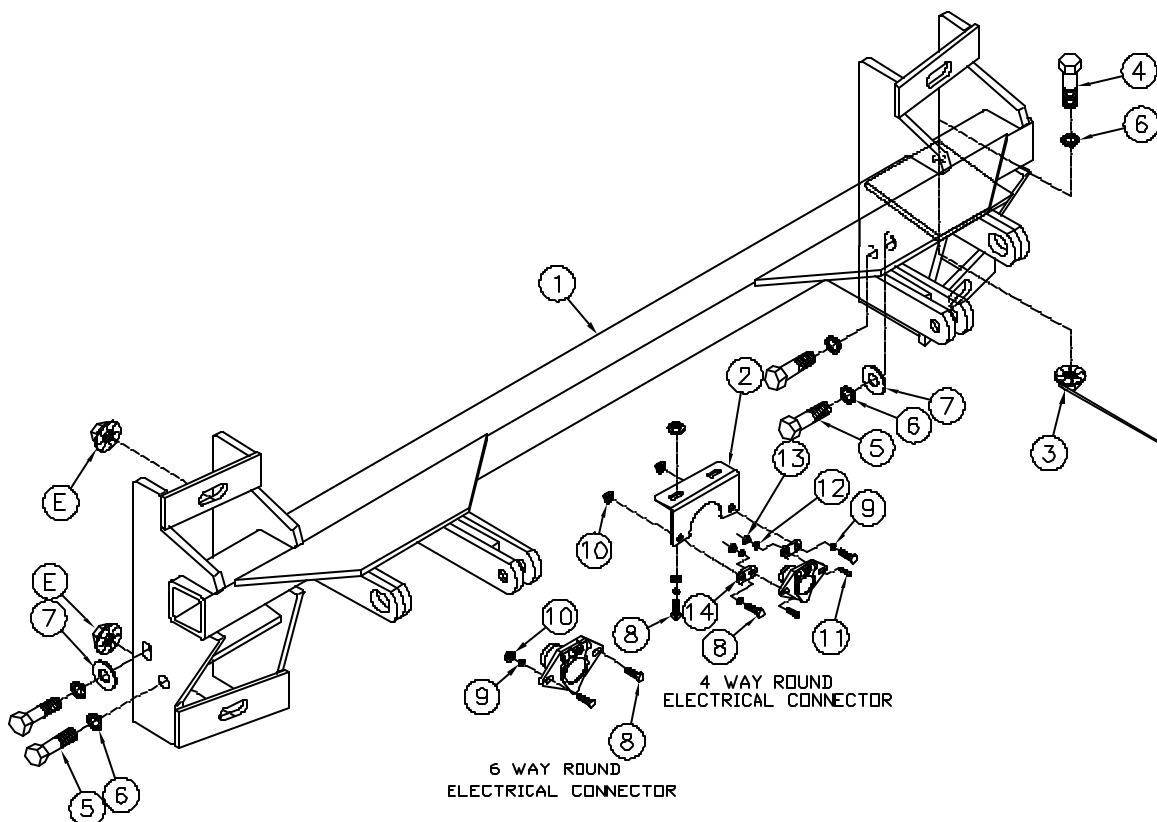

IMPORTANT: Use only genuine factory replacement parts on your Base Plate. Do not substitute homemade or nontypical parts. If a bolt is lost or in need of replacement, for your safety and the preservation of your Base Plate, be sure to use a replacement bolt of the same grade (Usually Grade 5, refer to parts list). Repair parts may be ordered through your nearest **Blue Ox** dealer or distributor.