



BX2132

1997-00 Ford Expedition

Installation Instructions

Installation of this baseplate requires removing the lower molding of the front bumper. Holes will need to be drilled into the bottom of the vehicle's frame. The bumper will need to be notched to allow the attachment tabs to protrude.

1. Read the General Instruction Sheet included with this baseplate.
2. The baseplate (Item 1) mounts to the bottom of the frame using six bolts supplied with the baseplate.
3. Remove the lower molding of the front bumper.
4. The six holes for the baseplate (Item 1) will need to be drilled (17/32" drill bit) in the bottom of each frame. NOTE: If there are tow hooks on the vehicle, they will need to be removed, and the holes will not be used in the installation. To mark these holes, clamp the baseplate (Item 1) and the 1/4" flat spacers (Item 2) to the bottom of the frame with the front edge of the mount plates flush with the front edge of the frame (as shown on the diagram). When the baseplate is in position, punch and drill the holes. NOTE: The " Eddie Bauer " series frames are even. Use four flat spacers (Item 2) on each end of the baseplate rather than all on the passenger side.
5. Bolt the baseplate (Item 1) to the frame using the 1/2" x 1-1/2" bolts (Item 7) for the front two holes, and the 1/2" x 2-1/2" bolts (Item 5) for the back holes, the nuts (Item 8) and the lock washers (Item 6). The wire nuts (Item 3) will be used with the rear bolts (Item 5) . Use Loctite to ensure the bolts will not work loosen.
6. Now the bumper can be put back on. Place the bumper in its original position and mark the spot where the attachment tabs meet the plastic molding attached to the bumper. Be sure to double check your marks. You will need to notch out a 1-1/2" x 1-1/2" square to allow for the attachment tabs to protrude. You will need help to do this step. Once the squares are notched, bolt the bumper back on to the frame.
7. The dimensional variations between otherwise identical cars can be considerable. While the location and size of the holes in the baseplate were designed to allow for easy installation, it may be necessary to file a hole slightly to allow a bolt to clear.
8. Install the tow bar and safety cables according to the instructions included in their packages.
9. Do not substitute other devices if the tow bar pin and clip are lost.
10. DEALER OR INSTALLER: BE CERTAIN THE USER RECEIVES THE INSTRUCTION SHEET.

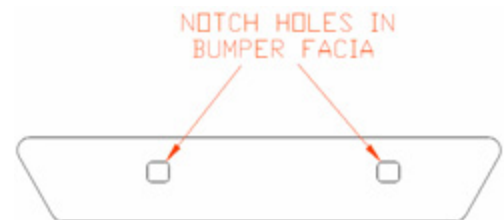
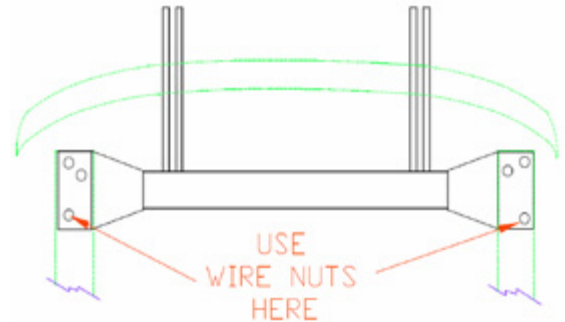

BX2132 1997-00 Ford Expedition Installation Instructions

3/4" Wrench
3/4" Socket
Hammer

Tools Required
17/32" Drill Bit
Drill
Center Punch

Loctite
Utility Knife

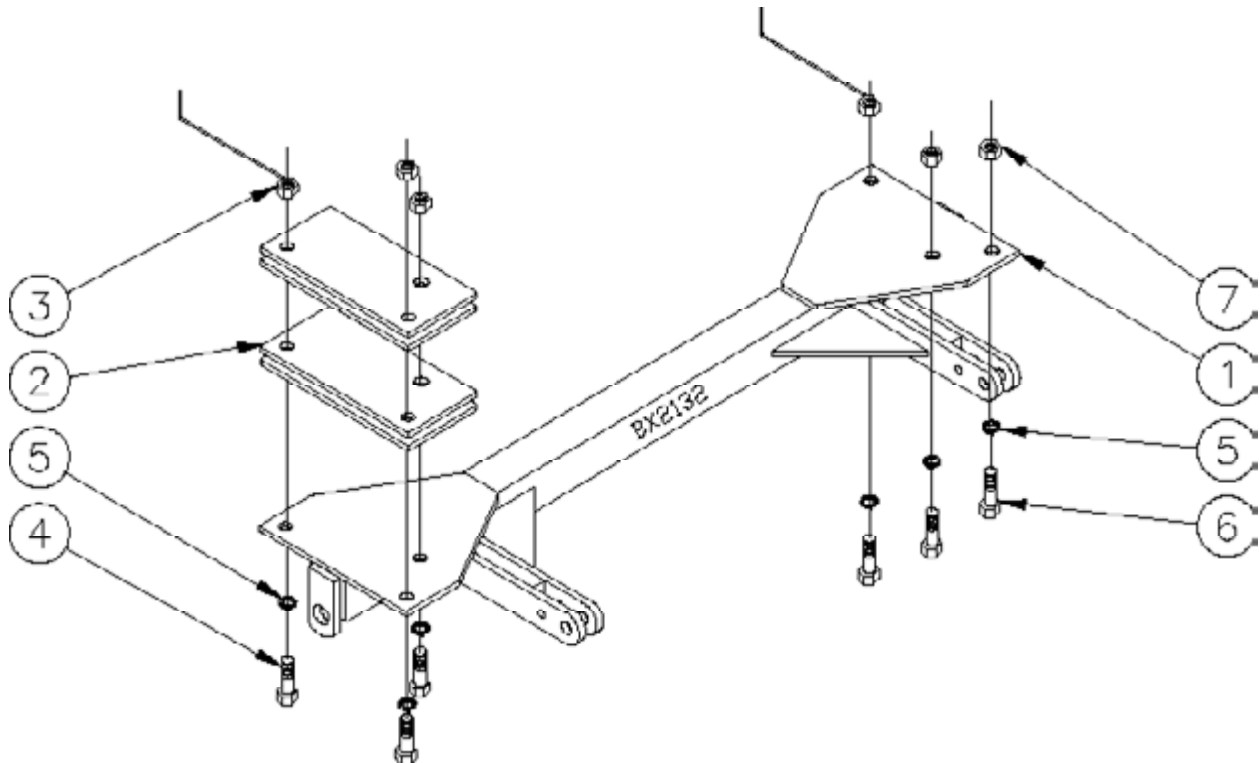

Parts List

Ref. No.	Qty.	Part No.	Description
1	1	61-4959	Baseplate, BX2132
2	8	102-5289	Flat Spacer, BX2132
3	2	61-4029	1/2" Wire Nut
4	6	201-0153	1/2" x 2 1/2" Hex Bolt, Grade 5
5	6	203-0012	1/2" Lock Washer
6	6	201-0051	1/2" x 1 1/2" Hex Bolt, Grade 5
7	4	202-0005	1/2" Hex Nut