



BX2147 Installation Instructions 1999-01 Lincoln Navigator

Serial Number

The baseplate mounts to the tow hooks using four bolts provided in the baseplate. Because of the variation of weights for the trucks being close to or over 5,000 lbs., this baseplate is designed for a Class IV rated tow bar only. A car mounted tow bar will not work with this baseplate.

1. Hold the baseplate (Item 1) up to the bottom of the tow hooks so the inserts fit inside the tow hooks on the truck.
NOTE: It may be necessary to loosen and adjust the tow hooks so the inserts fit. Tighten tow hook bolts after adjusting.

2. Place the top plates (Item 2) over each tow hook and thread the 7/16" bolts into the top plates as shown in the diagram. Be sure to use Loctite on each bolt.

3. Once all four bolts are started into the top plates, tighten and torque according to the Torque Chart in the General Instruction Sheet.

4. Do not substitute other devices if the tow bar pin and clip are lost

5. Install the tow bar and safety cables according to the instructions included in their packages.

4. DEALER OR INSTALLER: BE CERTAIN THE USER RECEIVES THE INSTRUCTION SHEET.

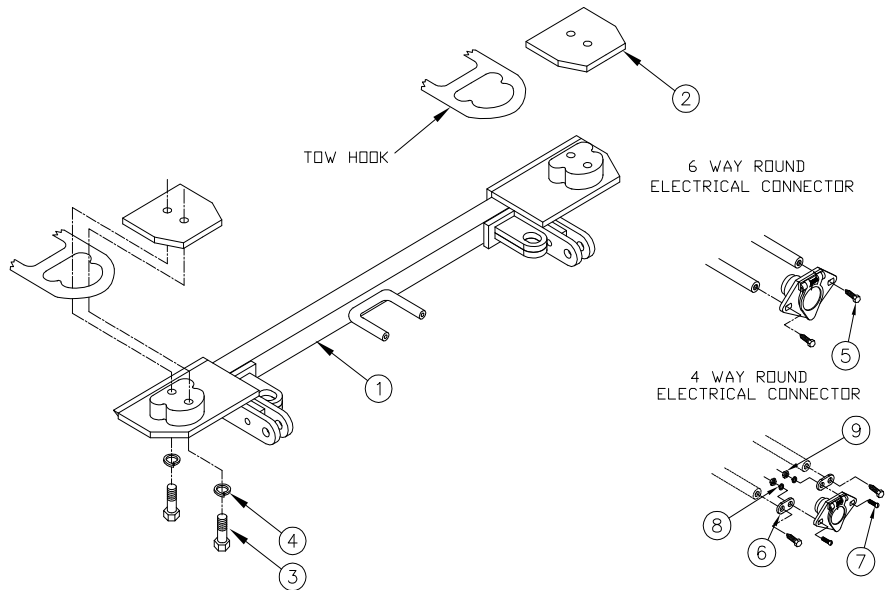

Tools Required

7/16" Wrench
Screwdriver

Loctite

5/8" Wrench

19mm Wrench

Flat Head

Parts List

Ref. No.	Qty.	Part No.	Description
1	1	61-5344	Baseplate, BX2147
2	2	102-5725	Top Plate, BX2146
3	4	201-0552	7/16-14 x 2 Hex Head Bolt, Grade 5
4	4	203-0011	7/16" Lock Washer
5	2	201-0979	#12-14 x 1" Self Drilling Screw, ZP
6	2	101-5822	Adapter, Four Way Electrical Connector
7	2	201-0192	#10 - 32 x 1/2" Slotted Screw
8	2	203-0054	#10 Lock Washer
9	2	202-0047	#10 Hex Nut
10	1	63-2388	Bolt Bag, BX2146/BX2147 (not shown)

Automatic