

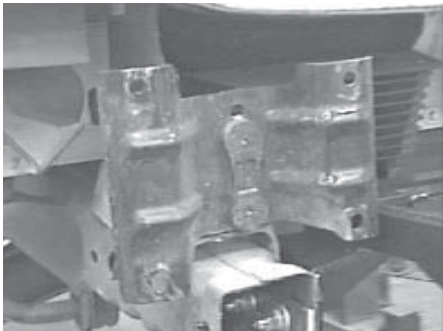

Serial No.

Installation Instructions BX2155
1999- 03 Ford F-150 XLT 2WD (Include Crew/ Super Cab)

The front bumper and lower plastic rock guard is temporarily removed. All holes need to be drilled. **The car mounted tow bar or adapters can not be used with this vehicle due to weight restrictions.** The Aventa II is the recommended tow bar with the rating of 10,000 Lbs. **Use Loctite on all bolts.**
Installer: Be sure the customer receives instruction sheet.



1. Remove the four metric bolts (on each side) from the back side of the bumper which hold it to the frame brackets.



2. Hold the baseplate up to the bottom of the frame positioning it so it is flush with the bottom of the frame.

3. There may be a gap on the inside of the frame where the baseplate sits, this is fine. Clamp the baseplate to the frame and drill the bottom holes for each side. Use 1/2" hardware as shown in drawing on last page. **Be sure and use loctite on all bolts before tightening.**

4. Bolt the bumper back on the vehicle with one or two bolts only. If the attachment tabs interfere with the installation, by hitting the top of the grill opening, remove the baseplate and place one of the backing plates in between the bottom holes and the frame to lower the attachment tabs. See drawing on last page. Bolt the baseplate and backing plate with another backing plate on the inside of the frame for extra strength.

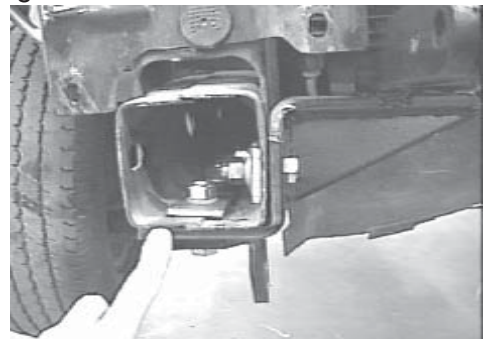

5. Once the bottom holes are drilled, do the same for the side holes. Use hardware shown and tighten all bolts according to the chart in the General Instruction Sheet. **Be sure and use loctite on all bolts before tightening.** Replace the bumper and rock guard.

Automatic

Parts List

Ref. No.	Qty.	Part No.	Description
1	1	61-5543	Weldment, Base Plate, BX2155
2	6	102-6024	Backing Plate, slotted
3	4	201-0153	1/2-13 x 1 1/2 Bolt Hex Grade 5, ZP
4	4	201-0051	1/2-13 x 2 1/2 Bolt Hex Grade 5, ZP
5	4	203-0005	1/2 Flat Washer, ZP
6	8	203-0012	1/2 Lock Washer, ZP
7	8	202-0005	1/2-13 Hex Nut, ZP
8	1	101-6058	Convenience Link, Class IV, Driver Side
9	1	101-6059	Convenience Link, Class IV, Passenger Side
	2	226-0049	Baseplate Safety Cable, 36" CL IV (Not Shown)
	4	229-0512	Quicklink, 1/2, ZP (Not Shown)

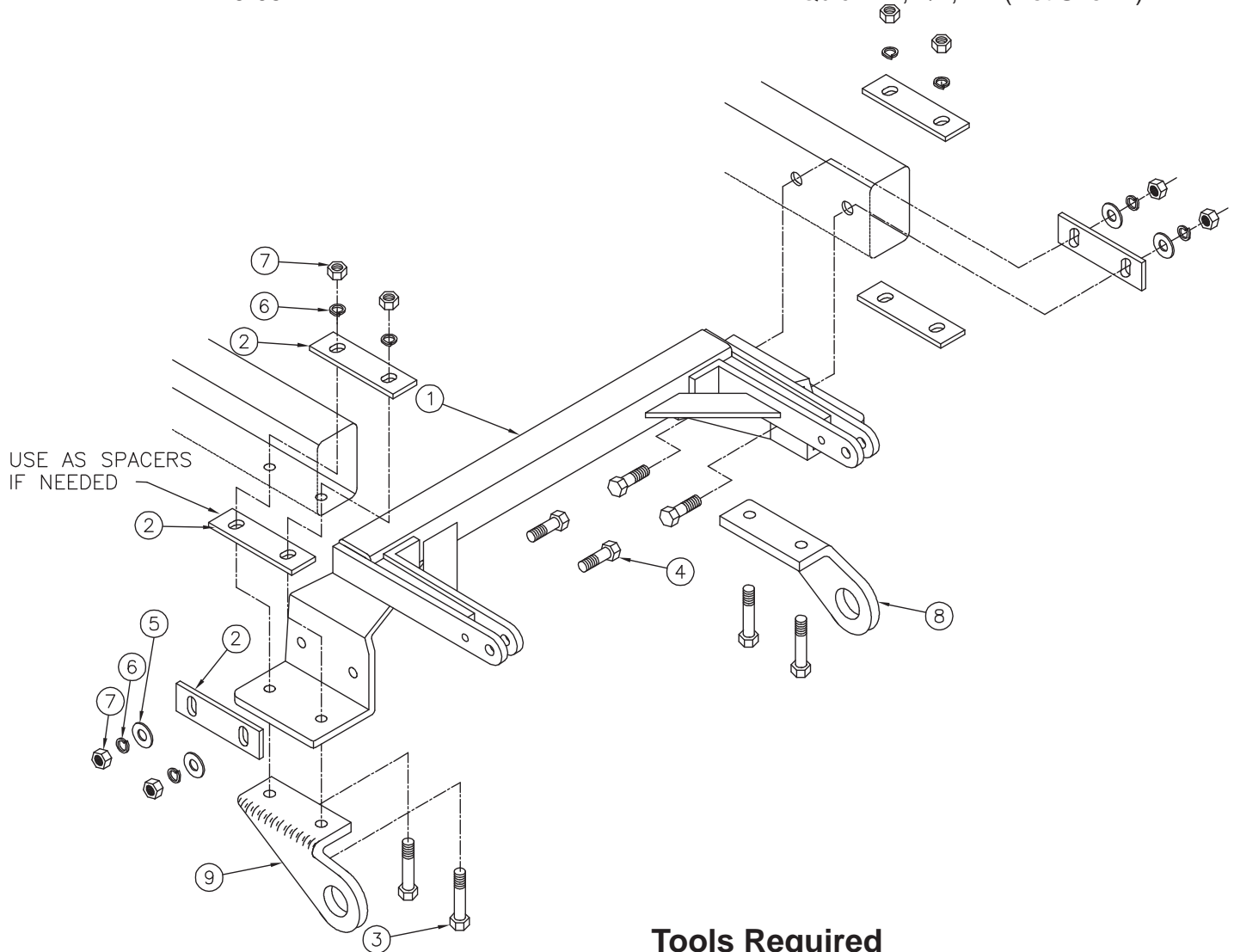

Tools Required

13MM Wrench
3/4" Wrench

Loctite Blue
Vise Grips

17/32" Drill Bit