

Tools Required

19mm Wrench
3/4" Wrench
8mm Wrench

Loctite Blue
Vise Grips
Phillips Screw Driver

17/32" Drill Bit
11mm Wrench
Utility Knife

Parts List

Ref. No.	Qty.	Part No.	Description
1	1	61-5552	Weldment, Base Plate, BX2156
2	4	61-3799	Weldment, 1/2 Nut Plate w/Wire
3	2	201-0581	1/2 -13 x 4 Hex Bolt, Grade 5, ZP
4	4	201-0068	1/2-13 x1 3/4 Hex Bolt, Grade 5, ZP
5	6	201-0051	1/2-13 x 1 1/2 Hex Bolt, Grade 5, ZP
6	8	202-0005	1/2-13 Hex Nut, ZP
7	12	203-0012	1/2 Lock Washer, ZP
8	6	203-0005	1/2 Flat Washer, ZP
9	2	106-0357	Spacer Tube
10	1	101-6069	Bracket, PS, BX2156
11	1	101-6068	Bracket, DS, BX2156 (not shown)

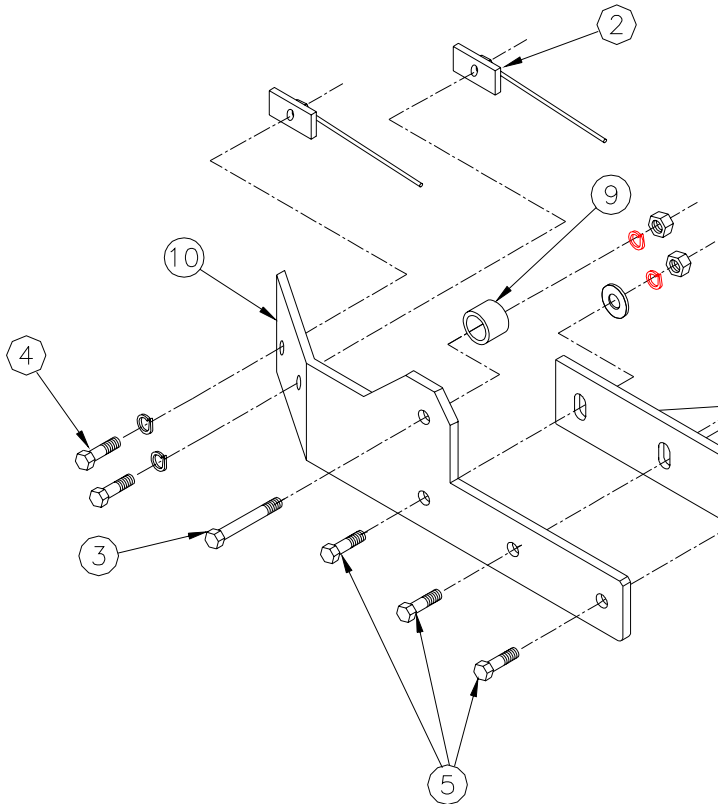

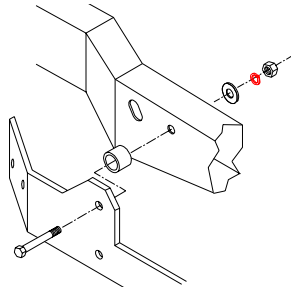
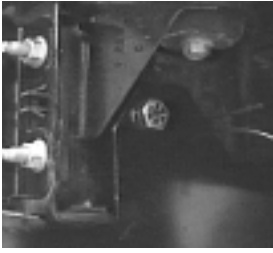

7. Remove the existing bolt from the frame and bolt the side plates with the spacers to the side of each frame using the 1/2 x 4" Hex bolt and 1/2" hardware.



8. The pieces extending down from the bumper need to be pushed up so they do not interfere.

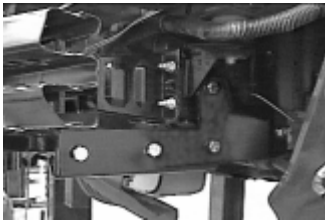

9. Bolt the baseplate to the side plates use the 1/2" hardware as shown in drawing on the last page. Tighten bolts according to the chart in the General Instruction Sheet.

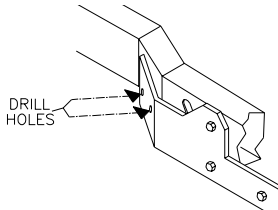
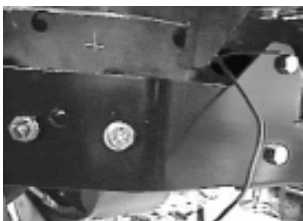

10. Drill the remaining holes for the side plates. Use the hardware as shown in drawing. The wire nut plates can be inserted through the slots just above the side plates. Tighten bolts.

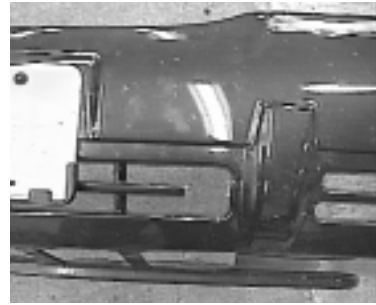

11. Hold the bumper facia up to its original position and mark areas which will allow the attachment tabs to extend through.



12. Both sides of the grill need to be trimmed out.





**BX2156 Installation Instructions
1999 Ford Mercury Grand Marquis**

Serial No.

The front bumper and headlights are removed for baseplate installation. Holes need to be drilled. If customer is using a car mounted tow bar it is necessary to use either a BX88133 or a BX88135.



1. Remove Phillips screws from side of turn lights.



4. Remove the push pins forward of the front tires.



2. Open hood and remove bolt holding turn lights. Pull lights out and set aside.



5. Remove the screws from the bottom of the bumper fascia.



3. Remove the bolts from bumper fascia exposed once turn lights are removed.



6. More screws from the bottom of the bumper fascia. Remove fascia and set aside.

Automatic