



Baseplate Installation Instructions

BX2189

# 2007-10 Lincoln Navigator Installation Instructions

Serial Number

Please read BOTH these Installation Instructions and the General Towing Instructions before attempting to install or operate this equipment.

1. Blue Ox® towing products and accessories are intended to be installed by Blue Ox® Dealers who are familiar with our products and have the equipment and knowledge to do “fit work.” When necessary, Blue Ox® Dealers can be found at [www.blueox.com](http://www.blueox.com) or by contacting our Customer Care Department at (402) 385-3051.

Attachment Tab Height: 24”

Attachment Tab Width: 24”

2. Many Blue Ox® Baseplates are designed to use existing holes and hardware to mount the baseplate to the towed vehicle. Even though bolts are there, do not assume they are adequate for baseplate mounting. Always use hardware supplied in the hardware kit or existing hardware specified in the Baseplate Towing Installation Instructions.

### Bolt Torque Specifications

Torque in Foot-Pounds for Metric Bolts

Bolt Size	Grade 8.8	Grade 10.9
6MM	6	8
8MM	16	22
10MM	31	40
12MM	54	70
14MM	89	117

Confirm the towability and pre-towing procedures for your vehicle with the owner’s manual or contact the vehicle’s manufacturer for specific towing procedures.

### Bolt Torque Specifications

Torque in Foot-Pounds for Inch Bolts

Bolt Size	Grade 5	Grade 8
1/4”	10	14
5/16”	19	29
3/8”	33	47
7/16”	54	78
1/2”	78	119
5/8”	154	230

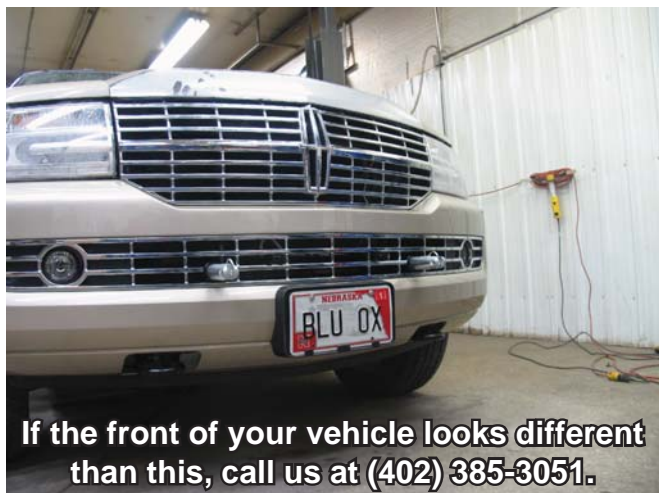

If the front of your vehicle looks different than this, call us at (402) 385-3051.



## WARNING

Failure to read and follow these instructions could result in separation of the towed vehicle from the tow bar, causing property damage, loss of towed vehicle, personal injury or death.

# BX2189

## 2007-10 Lincoln Navigator

### Installation Instructions

## Parts List

Ref. No.	Qty.	Part #	Description
1	1	61-6363	Weldment, Base Plate, BX2189
2	8	201-0068	1/2-13 x 1 3/4" Hex Bolt, GRD. 5, ZP
3	8	203-0012	1/2" Lock Washer, ZP
4	8	61-4029	Weldment, 1/2" Nut Wire
5	1	101-6135	Electrical Bracket, 90 Degrees
6	4	201-0569	1/4-20x3/4" Hex Head Bolt, GRD. 8, ZP
7	4	203-0008	1/4" Lock Washer, ZP
8	2	203-0001	1/4" Flat Washer, ZP
9	4	202-0069	1/4-20 Hex Flange Whiz Lock Nut, ZP
10	2	201-0192	#10-32x1/2" Slot, Round Head Screw
11	2	203-0054	#10 Lock Washer
12	2	202-0047	#10-32 Hex Nut
13	2	101-5822	Adapter, 4 Way Connector
14	2	62-3469	Attachment, Assembly, SF/LB, 1 Hole
	2	290-0437	Cap Plug, Black (Not Shown)
	2	229-0512	Quicklink, 1/2", ZP (Not Shown)
	2	226-0049	Baseplate Safety Cable, 36" Class IV (Not Shown)

## Tools Required

- Loctite® RED
- Vise Grips
- 30 Torx Socket
- 7mm Socket
- 10mm Socket
- 17/32" Drill Bit
- Utility Knife

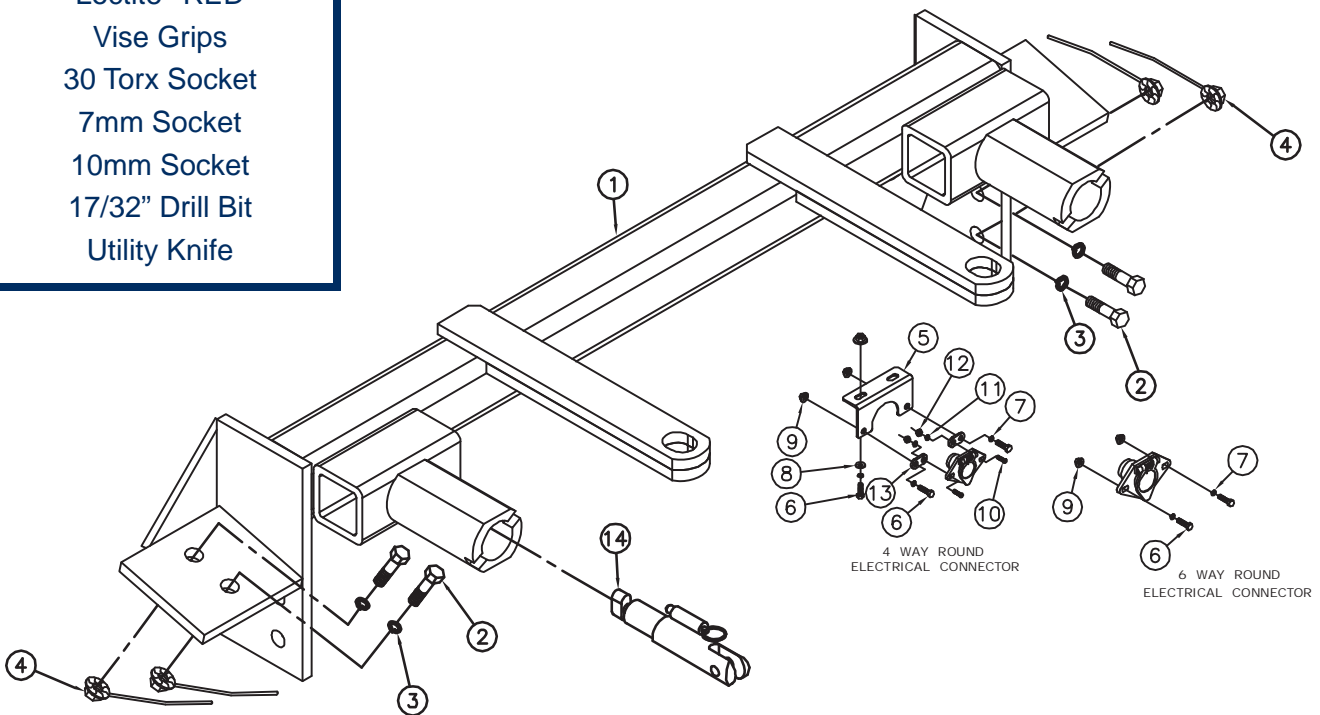

## Important:

Use only genuine factory replacement parts on your baseplate. Do **NOT** substitute homemade or non-typical parts. If a bolt is lost or in need of replacement, for your safety and the preservation of your baseplate, be sure to use a replacement bolt of the same grade (In most cases it will be Grade 5, please reference the parts list above). Replacement parts may be ordered through your nearest Blue Ox® Dealer or Distributor. Failing to follow and/or altering these installation instructions in either installation or required equipment will void the manufacturer's warranty. Towing behind a non-motorized vehicle will void the warranty.

# 2007-10 Lincoln Navigator

## Installation Instructions

### Vehicle Weight:

The weight of this vehicle is near the Class III, 5,000 lbs. rating limitations. Some models, depending on options, may well exceed this 5,000 lb rating. Be sure to confirm the weight of your individual vehicle before towing. As of 1999 the Aventa® II is now rated 10,000 lbs. and either the Aventa® II or the Aventa® LX tow bar must be used for these applications.

**Tow Bar Adapters are NOT to be used with vehicles weighing over 5,000 lbs.**

**Installation Notes:** The fascia, bumper and belly pan cover are removed for installation. Drilling is required.

The dimensional variations between otherwise identical vehicles can be considerable. While the baseplate was designed for easy installation, it may be necessary to tailor the baseplate slightly to compensate for auto manufacturer's tolerances. These minor adjustments may include filing a hole slightly, bending electrical rods or bending end plates.

The BX8869 Bulb and Socket Wiring Kit is recommended for this vehicle.



**Possible location for the BX8869 Bulb and Socket Wiring Kit.**

### Installation Instructions:

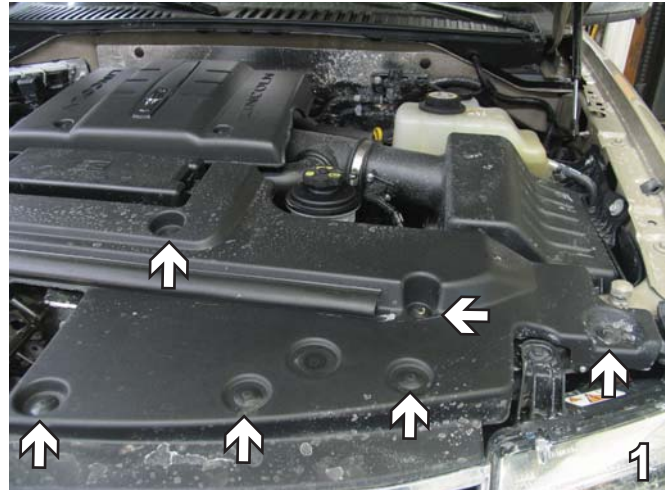

1. Using a phillips screw driver, remove 6 plastic phillips head pins. Do this to both sides of the vehicle. Set pins aside to be reinstalled later.



2. Using a flat screwdriver, remove one pushpin (see gray arrow). Then using a 30 torx socket, remove two bolts (see white arrows). Do this to both sides of the vehicle. Set pushpin and bolts aside to be reinstalled later.

Handling of some cosmetic parts when installing this product may require the use of protective covers, rags, specialty tools, etc. to prevent damage.



BX2189  
2007-10 Lincoln Navigator  
Installation Instructions



3. Just forward the front tire on the wheel well, remove two bolts using a 7MM socket. Do this to both sides of the vehicle. Set bolts aside to be reinstalled later.

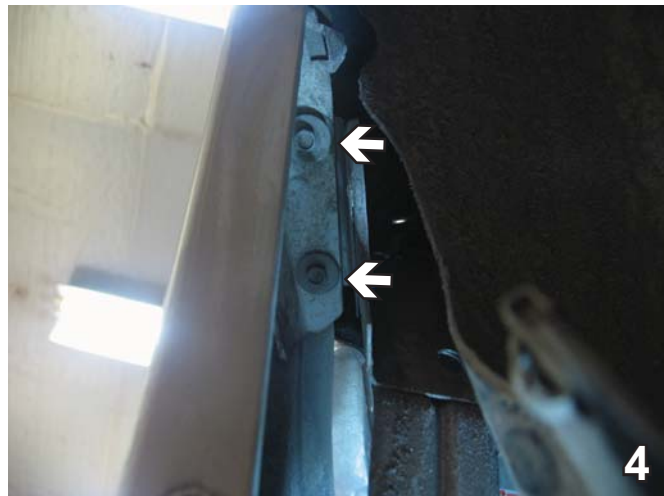

4. Once bolts are removed from the wheel well, pull plastic back away from bumper and remove two bolts with a 10MM socket. Do this to both sides of the vehicle. Set bolts aside to be reinstalled later.



5. Using a flat screwdriver, remove three christmas trees from the belly pan cover located under the bumper. Set christmas trees and cover aside to be reinstalled later.

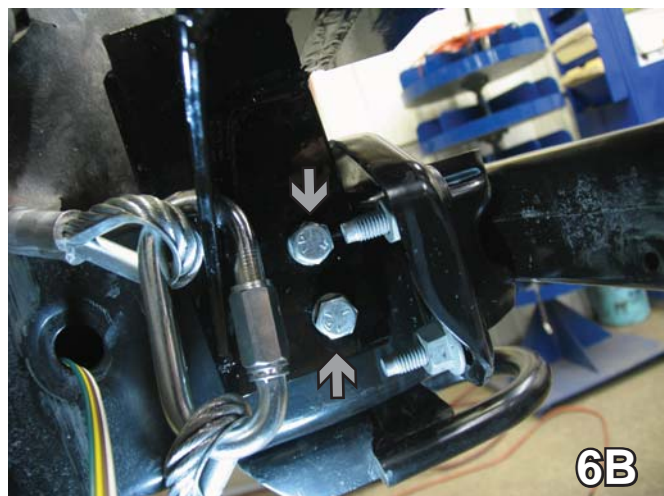

# 2007-10 Lincoln Navigator

## Installation Instructions

- Position baseplate on top of the frame and slide it all the way forward. Use vise grips to secure in place while drilling out holes. Using the baseplate as a template, drill top two holes into the frame first with a 17/32" drill bit (see picture 6A with white arrows). Insert 1/2" nut wire into the frame underneath and align with drilled holes. Insert the 1/2-13X1 3/4" hex bolts and 1/2" lock washers and tighten down. Repeat the same steps above for the two holes located on the inside of the frame on the baseplate (see picture 6B with grey arrows). Do this to both sides of the vehicle.

When using power drills be aware of the dangers of torque and drill bit length.

**BE SURE TO USE LOCTITE® RED ON ALL BOLTS BEFORE TIGHTENING. TIGHTEN ALL BOLTS ACCORDING TO THE TORQUE CHART ON THE FRONT PAGE OF THESE INSTRUCTIONS OR ON PAGE 3 OF THE BASEPLATE TOWING GENERAL INSTRUCTIONS.**



- Align the fascia to its original position and using a utility knife, trim grille area in front of the attachment tabs. This will then create an opening for the tabs to come through, when reinstalling the fascia. Do this to both sides of the vehicle.

- Attach the permanent baseplate safety cables to a solid piece of the vehicle frame, which are described in the instructions, included with the permanent baseplate safety cables.

Be sure that **ALL** electrical connections are plugged in properly and functioning **BEFORE** installing the fascia.

- Reinstall bumper, fascia, belly pan cover, bolts and pushpins. The installation of the baseplate is complete.
- We recommend placing the electrical bracket under the license plate.

Install the tow bar and safety cables according to the instructions provided in their packages. When demonstrating this to the customer, be sure to include all the contents and packages.

Do **NOT** substitute other devices if the tow bar pins and clips are misplaced.

**DEALER or INSTALLER:**  
Be certain the user receives the instruction sheets for their products.

BX2189  
2007-10 Lincoln Navigator  
Installation Instructions



**Shown without removable tabs installed.**

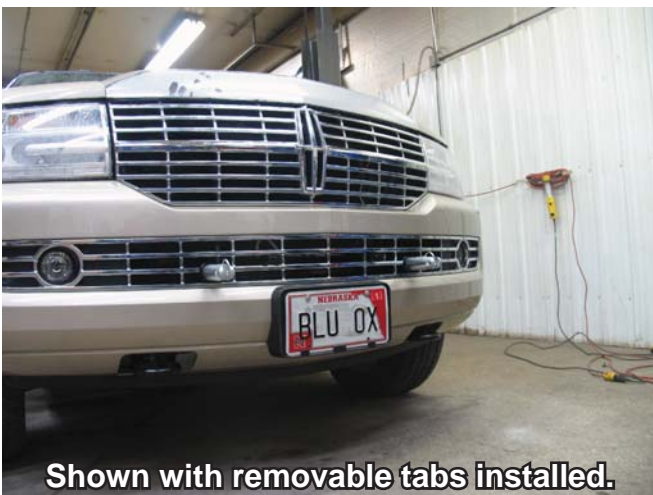

**Shown with removable tabs installed.**

If the baseplate is in an accident, it must be replaced. DO NOT use it again! An accident can cause unseen damage and using it again could result in more damage or serious injury. DO NOT use the baseplate if it is damaged or missing parts.

**CUSTOMER SERVICE COMMITMENT**

Blue Ox is committed to providing you with exceptional customer care throughout your lifetime with our products. Our team is here to assist you with any questions you may have regarding the performance of your product. Simply call (402) 385-3051 and you can speak with our customer care team.

Additionally, please visit our website to see which rallies our Destination America team will be attending. For a nominal fee, our service technician will service your towing system to ensure it's in proper working condition. Also as a commitment to our customers, should you visit our factory you can stay at our full service Blue Ox campground at no charge along with enjoying a factory tour.

Again thank you for being our customer and for the confidence you have shown in the performance of our products. It is because of customers like you we enjoy the success we have today.



© 2007, 10 Blue Ox  
One Mill Road, Industrial Park  
Pender, Nebraska 68047  
Phone: (402) 385-3051 • Fax: (402) 385-3360  
[www.blueox.com](http://www.blueox.com)