



Baseplate Installation Instructions

BX2190

2007-10 Ford Edge Installation Instructions

Serial Number

Please read BOTH these Installation Instructions and the General Towing Instructions before attempting to install or operate this equipment.

1. Blue Ox® towing products and accessories are intended to be installed by Blue Ox® Dealers who are familiar with our products and have the equipment and knowledge to do “fit work.” When necessary, Blue Ox® Dealers can be found at www.blueox.com or by contacting our Customer Care Department at (402) 385-3051.

Attachment Tab Height: 26 1/2”

Attachment Tab Width: 26”

2. Many Blue Ox® Baseplates are designed to use existing holes and hardware to mount the baseplate to the towed vehicle. Even though bolts are there, do not assume they are adequate for baseplate mounting. Always use hardware supplied in the hardware kit or existing hardware specified in the Baseplate Towing Installation Instructions.

Bolt Torque Specifications

Torque in Foot-Pounds for Metric Bolts

Bolt Size	Grade 8.8	Grade 10.9
6MM	6	8
8MM	16	22
10MM	31	40
12MM	54	70
14MM	89	117

Confirm the towability and pre-towing procedures for your vehicle with the owner’s manual or contact the vehicle’s manufacturer for specific towing procedures.

Bolt Torque Specifications

Torque in Foot-Pounds for Inch Bolts

Bolt Size	Grade 5	Grade 8
1/4”	10	14
5/16”	19	29
3/8”	33	47
7/16”	54	78
1/2”	78	119
5/8”	154	230

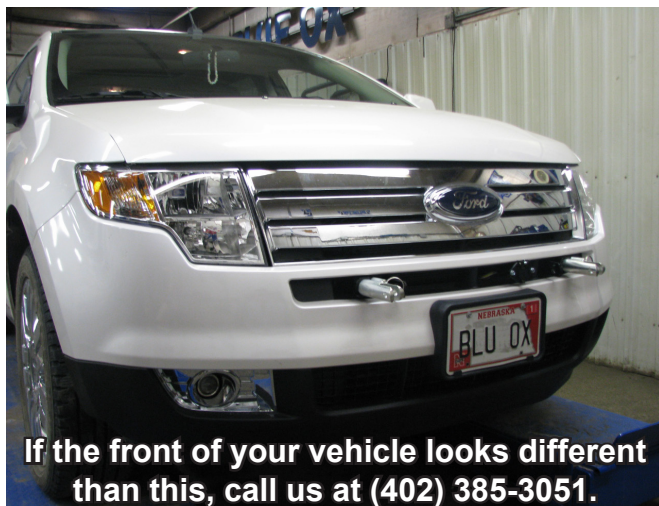

If the front of your vehicle looks different than this, call us at (402) 385-3051.

! WARNING

Failure to read and follow these instructions could result in separation of the towed vehicle from the tow bar, causing property damage, loss of towed vehicle, personal injury or death.

BX2190

2007-10 Ford Edge

Installation Instructions

Parts List

Ref. No.	Qty.	Part #	Description
1	1	61-6386	Weldment, Baseplate, BX2190
2	4	202-0071	3/8-16 Hex Flange Whiz Lock Nut, ZP
3	2	61-4029	Weldment, 1/2" Nut Wire
4	4	201-0443	3/8-16x1" Hex Bolt, Grd. 5, ZP
5	4	203-0010	3/8" Lock Washer, ZP
6	4	203-0003	3/8" Flat Washer, ZP
7	2	201-0060	1/2-13x1" Hex Bolt, Grd. 5, ZP
8	2	203-0012	1/2" Lock Washer, ZP
9	2	203-0005	1/2" Flat Washer, ZP
10	4		Existing Bolts
11	4		Existing Bolts
12	2	201-0979	#12-14 x 1" Self Drilling Screw, ZP
13	2	201-0192	#10-32x1/2" Slot, Round Head Screw
14	2	203-0054	#10 Lock Washer
15	2	202-0047	#10-32 Hex Nut
16	2	101-5822	Adapter, 4 Way Connector
17	2	62-3469	Attachment, Assembly, SF/LB, 1 Hole
	2	290-0437	Cap Plug, Black (Not Shown)
	2	229-0359	Quicklink, 3/8", ZP (Not Shown)
	2	226-0046	Baseplate Safety Cable, 36" Class III (Not Shown)

Tools Required

Loctite® RED	3/4" Socket
Phillips Screwdriver	9/16" Socket
Hammer	8MM Socket
Reciprocating Saw	13MM Socket
1 1/4" Hole Saw	10MM Socket
Utility Knife	5.5MM Socket

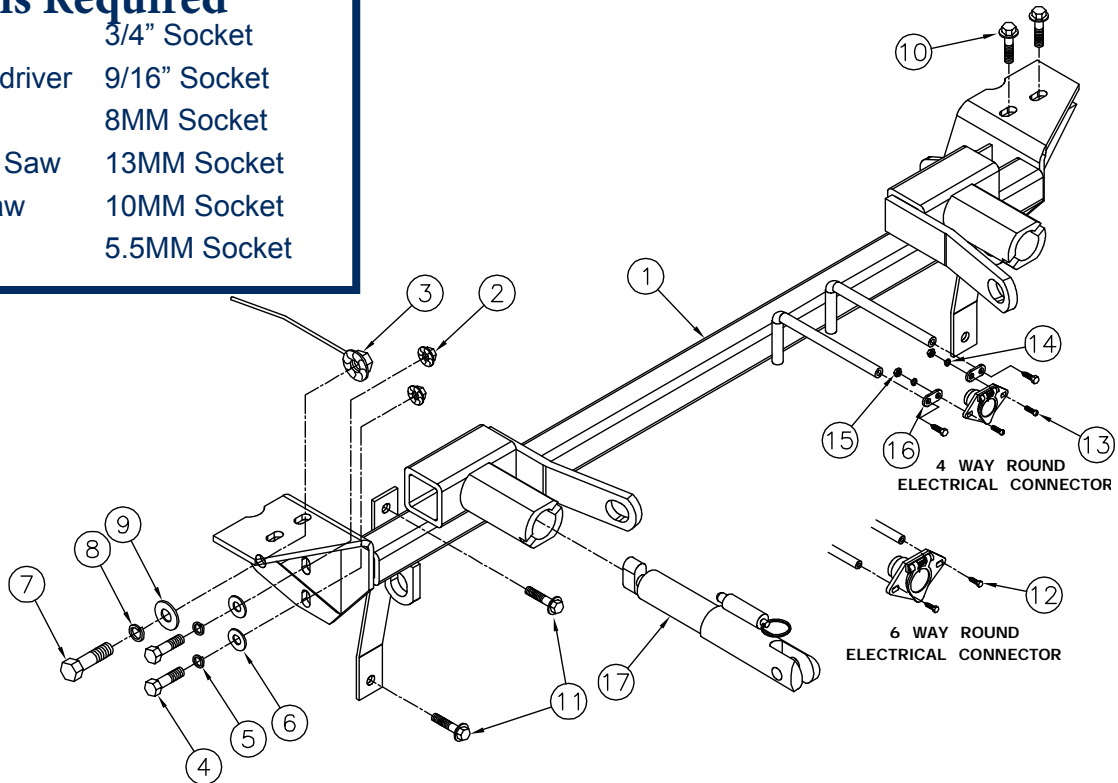

Important:

Use only genuine factory replacement parts on your baseplate. Do **NOT** substitute homemade or non-typical parts. If a bolt is lost or in need of replacement, for your safety and the preservation of your baseplate, be sure to use a replacement bolt of the same grade (In most cases it will be Grade 5, please reference the parts list above). Replacement parts may be ordered through your nearest Blue Ox® Dealer or Distributor. Failing to follow and/or altering these installation instructions in either installation or required equipment will void the manufacturer's warranty. Towing behind a non-motorized vehicle will void the

BX2190

2007-10 Ford Edge

Installation Instructions

Vehicle Weight:

Due to the design of the removable tabs, the RangeFinderII and Ambassador tow bars can not be used. Adapters, except the BX8833 and BX88151, can not be used with this baseplate.

Installation Notes: The fascia, headlight assemblies and water reservoir are removed and reinstalled during installation of the baseplate. Drilling is required. Trimming of the fascia is required.

The dimensional variations between otherwise identical vehicles can be considerable. While the baseplate was designed for easy installation, it may be necessary to tailor the baseplate slightly to compensate for auto manufacturer's tolerances. These minor adjustments may include filing a hole slightly, bending electrical rods or bending end plates.

The BX8848 Diode Wiring Kit is recommended for this vehicle.

Handling of some cosmetic parts when installing this product may require the use of protective covers, rags, specialty tools, etc. to prevent damage.

Installation Instructions:



1. Using a Phillips screwdriver, remove two plastic Phillips push pins (see white arrows) and then using a 10MM socket, remove one bolt (see grey arrow) from the flat plastic piece on top. Do this to both sides of the vehicle. Set bolts and push pins aside to be reinstalled later.



2. Using a 5.5MM socket, remove three bolts just forward of the front tire on the wheel well. Do this to both sides of the vehicle. Set bolts aside to be reinstalled later.

BX2190

2007-10 Ford Edge

Installation Instructions

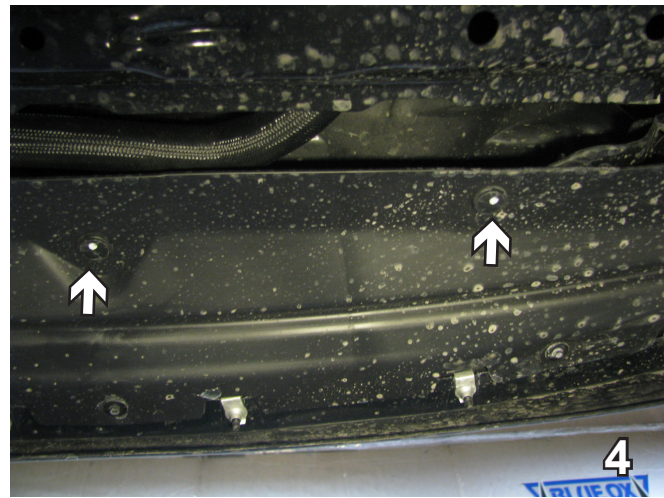

3. Using a 5.5MM socket, remove two bolts that are located underneath. Set bolts aside to be reinstalled later. Do this on both sides of the vehicle.

3. Using a flat screwdriver, remove three push pins across the middle. Set push pins aside to be reinstalled later. Pull the fascia up and out to remove from the vehicle and set aside carefully to be reinstalled later.

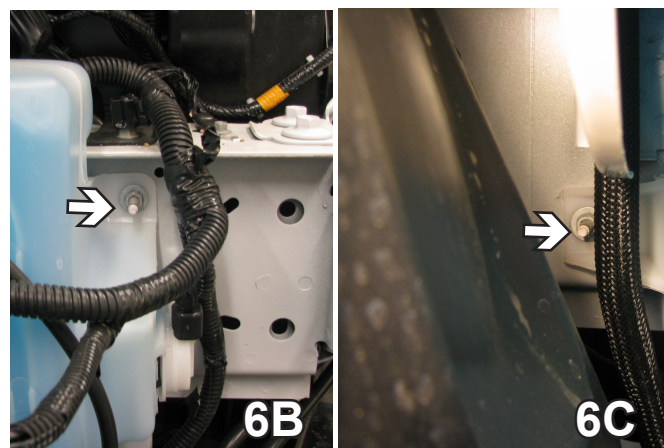
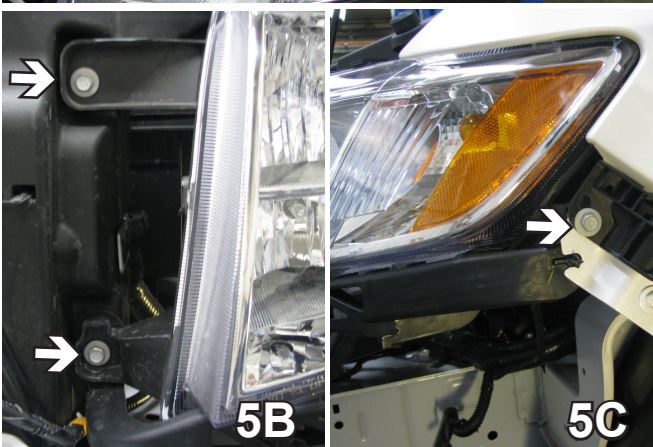
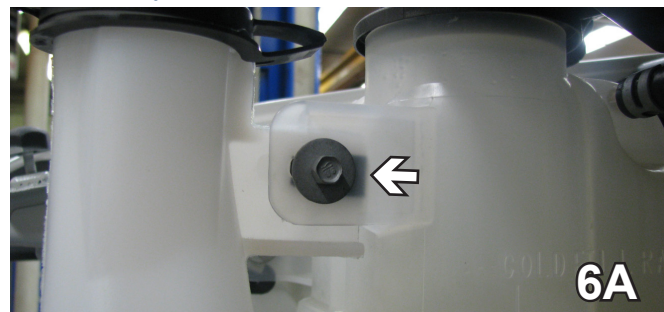

5. Using a 10MM socket, remove four bolts from the headlight assembly. Remove headlight by pulling it forward and disconnecting the electrical connections. Do this to both sides of the vehicle. Set headlight assemblies and bolts aside to be reinstalled later.

6. On the passenger side using an 8MM socket, remove one bolt from the top of the washer reservoir. Using a 10MM socket, remove two bolts one on each side. Disconnect the electrical connections and the hoses and remove the washer reservoir. Cap the fluid openings. Set the washer reservoir and bolts aside to be reinstalled later.

BX2190
2007-10 Ford Edge
Installation Instructions

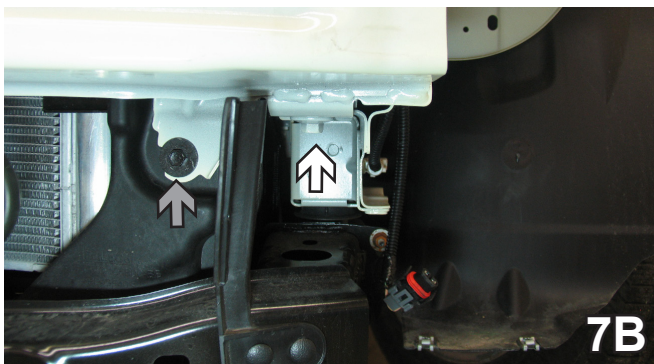
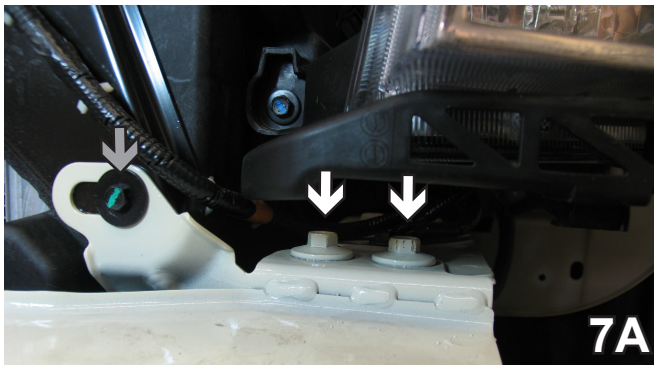

7. Using a 13MM socket, remove two bolts from the top of the metal bumper and one bolt from the bottom (see white arrows). Then using a 10MM socket, remove one bolt from the top of the bumper and one bolt from the bottom (see grey arrows). Do this to both sides of the vehicle. Set bolts aside to be reinstalled later and the metal bumper will not be reinstalled.

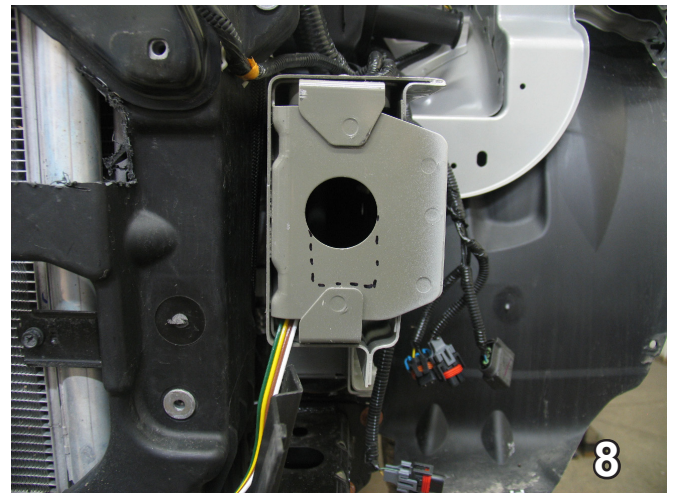
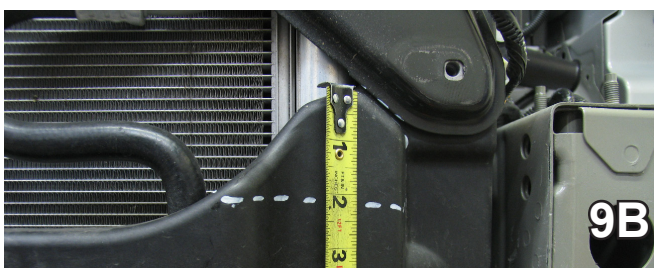
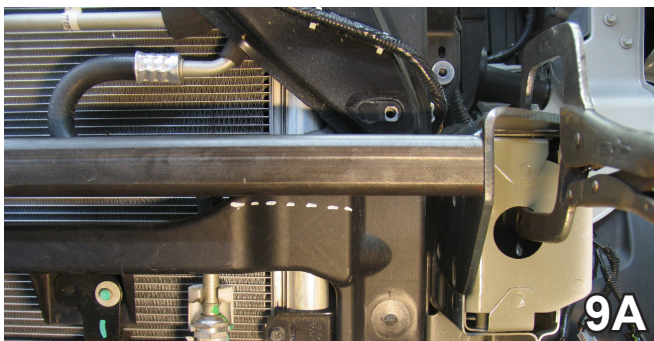

8. On the front of the frame, using a reciprocating saw, cut straight down on the dashed lines. Bend in across the bottom. Do this to both sides of the vehicle.

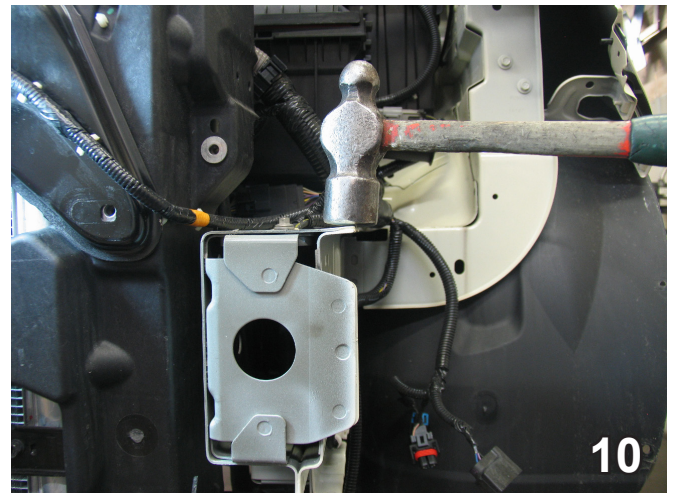

10. You will need to hit the top of the frame a couple times with a hammer to get it level. You can use a straight edge as a guide. Do this to both sides of the vehicle.
9. Set baseplate on top of frame and clamp into place with vise grips. You then need to take a marker and draw a line on the plastic piece below the tube (see photo 9A). Remove baseplate and using a reciprocating saw, trim away plastic area outlined in photo 9B. Do this to both sides of the vehicle. On the passenger side, be very careful not to damage the area behind.

BX2190

2007-10 Ford Edge

Installation Instructions

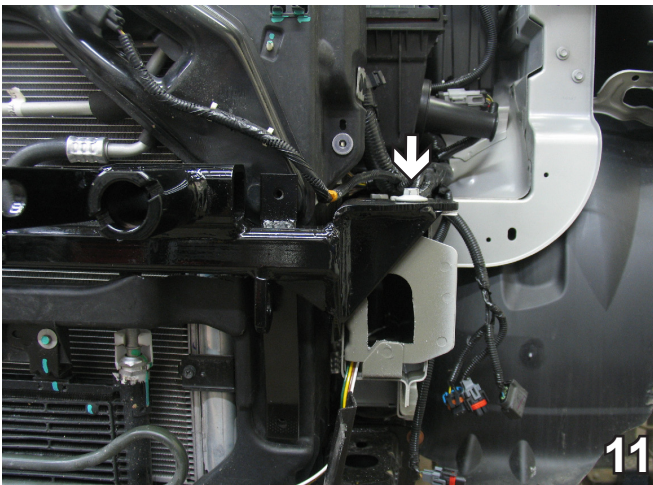

11. Place baseplate on top of frame and line up the holes in the baseplate with the existing holes on top of the frame. Insert one existing 13MM bolt removed in step 7, to hold baseplate into place. Do this to both sides of the vehicle. Use a floor jack to hold the radiator up in place.

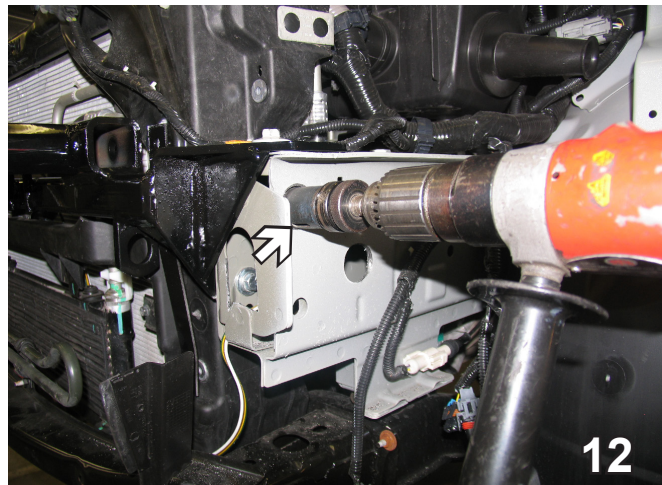

12. Using a 1 1/4" hole saw, drill two 1 1/4" holes into the frame, so an extension can be used to tighten up bolts. Do this to both sides of the vehicle.

When using power drills be aware of the dangers of torque and drill bit length.

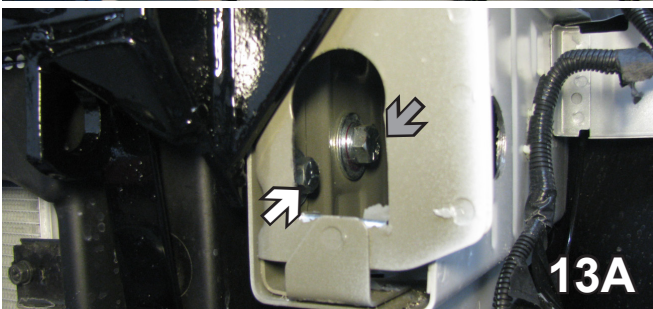
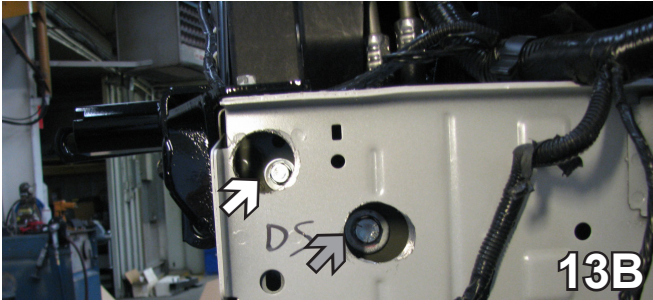

13. Using the baseplate as a template, insert 3/8-16x1" hex bolts with Loctite, 3/8" lock washers and 3/8" flat washers into the two outside holes and tighten down with a 3/8-16 hex flange whiz lock nuts (see white arrows). On the inside hole use a 1/2-13x1" hex bolt with Loctite, 1/2" lock washer and 1/2" flat washer tightened to a 1/2" wire nut inserted into the frame (see grey arrows). Do this to both sides.

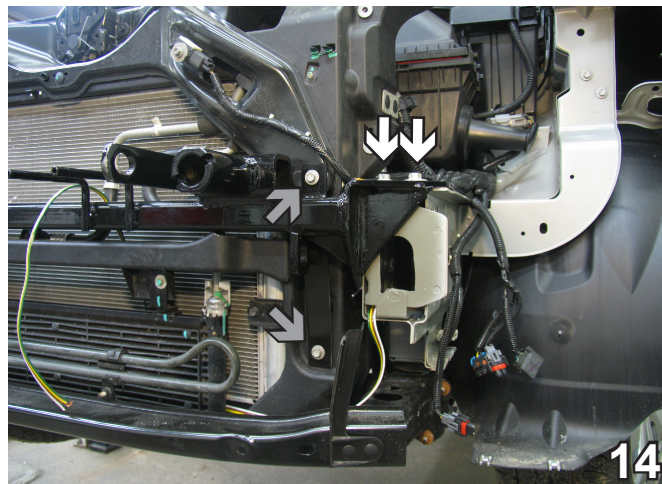

14. After the bolts in Step 13 are installed, you can reinstall the top two 13MM bolts (see white arrows) removed in Step 7 and also the two 10MM bolts (see grey arrows) removed in Step 7 to hold the radiator support back in place. Do this to both sides of the vehicle.

BE SURE TO USE LOCTITE® RED ON ALL BOLTS BEFORE TIGHTENING. TIGHTEN ALL BOLTS ACCORDING TO THE TORQUE CHART ON THE FRONT PAGE OF THESE INSTRUCTIONS OR ON PAGE 3 OF THE BASEPLATE TOWING GENERAL INSTRUCTIONS.

BX2190
2007-10 Ford Edge
Installation Instructions

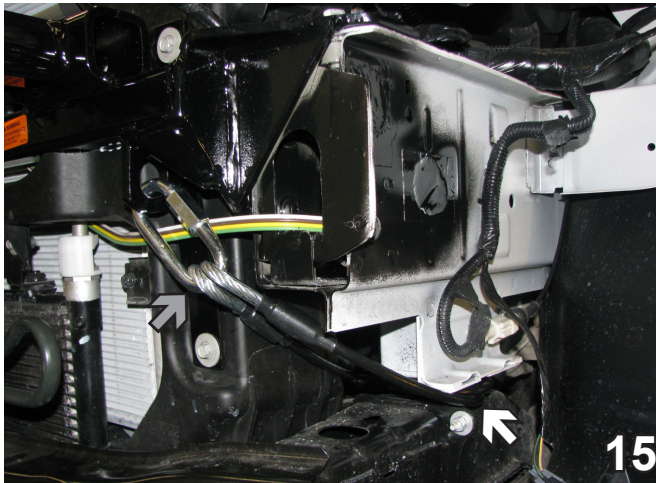

15. . Attach the permanent baseplate safety cables to the provided convenience link on the baseplate (see grey arrow). The photo above shows the recommended installation of the cables to frame of vehicle (see white arrow). Additional options may interfere with suggested mounting; in this case secure the cables to a solid piece of the frame as described in the instructions included with the permanent baseplate safety cables. Be sure the safety cables do not rub against any hoses or moving parts. Do this to both sides of the vehicle.

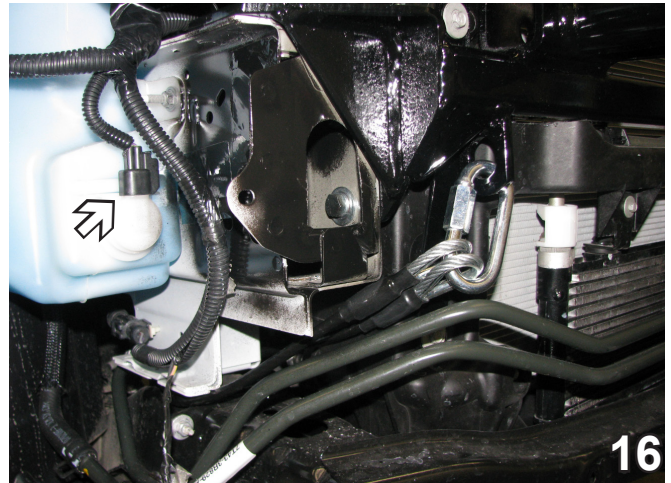

16. On the passenger side, reinstall the washer reservoir. Reconnect the electrical connections and the hoses.

17. Reinstall the headlight assemblies. Reconnect all electrical connections.

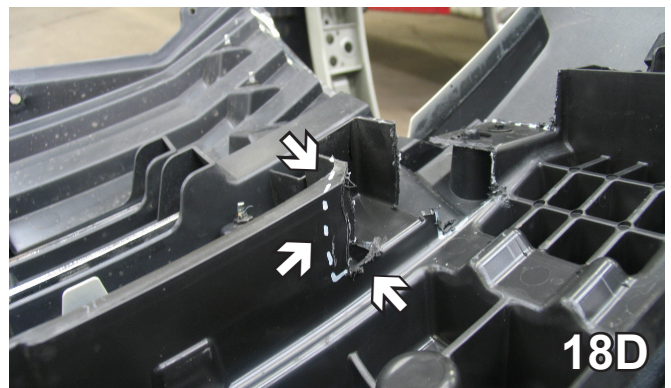
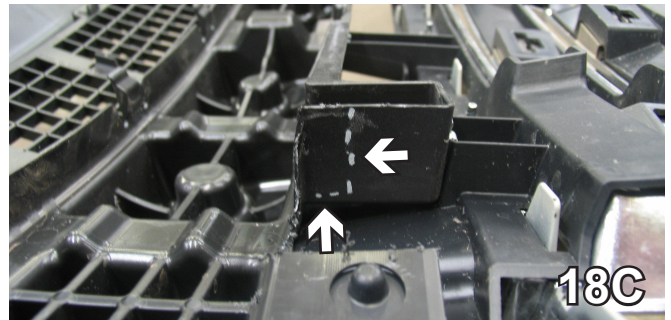
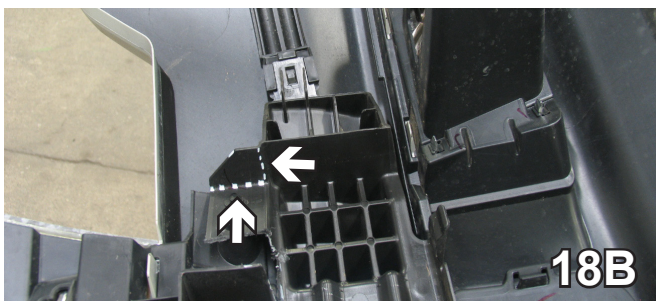
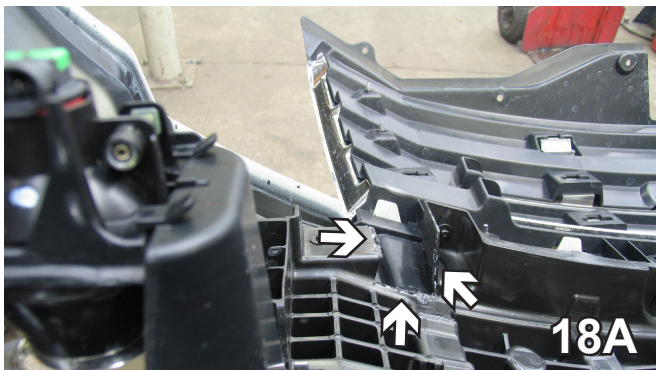

18. Using a reciprocating saw, trim away plastic areas located on the back side of the fascia, as indicated in photos 18A, 18B, 18C and 18D. Do this to both sides of the fascia.

BX2190

2007-10 Ford Edge

Installation Instructions

Be sure that **ALL** electrical connections are plugged in properly and functioning **BEFORE** installing the fascia.

Install the tow bar and safety cables according to the instructions provided in their packages. When demonstrating this to the customer, be sure to include all the contents and packages.

Do **NOT** substitute other devices if the tow bar pins and clips are misplaced.



If the baseplate is in an accident, it must be replaced. **DO NOT** use it again! An accident can cause unseen damage and using it again could result in more damage or serious injury. **DO NOT** use the baseplate if it is damaged or missing parts.

DEALER or INSTALLER:
Be certain the user receives the instruction sheets for their products.

CUSTOMER SERVICE COMMITMENT

Blue Ox is committed to providing you with exceptional customer care throughout your lifetime with our products. Our team is here to assist you with any questions you may have regarding the performance of your product. Simply call (402) 385-3051 and you can speak with our customer care team.

Additionally, please visit our website to see which rallies our Destination America team will be attending. For a nominal fee, our service technician will service your towing system to ensure it's in proper working condition. Also as a commitment to our customers, should you visit our factory you can stay at our full service Blue Ox campground at no charge along with enjoying a factory tour.

Again thank you for being our customer and for the confidence you have shown in the performance of our products. It is because of customers like you we enjoy the success we have today.



© 2007, 09, 10, 11 Blue Ox
One Mill Road, Industrial Park
Pender, Nebraska 68047
Phone: (402) 385-3051 • Fax: (402) 385-3360
www.blueox.com