



BLUE OX

Baseplate Installation Instructions

BX2319

2005-09 Hyundai Tucson Installation Instructions

Serial Number

Please read BOTH these Installation Instructions and the General Instructions before attempting to install or operate this equipment.

- Blue Ox® towing products and accessories are intended to be installed by Blue Ox® Dealers who are familiar with our products and have the necessary equipment and knowledge to do "fit work". When necessary Blue Ox® Dealers can be found at www.blueox.us or by contacting our Customer Care Department at (402) 385-3051.
- Many Blue Ox® baseplates are designed to use existing holes and hardware to mount the baseplate to the towed vehicle. Even though bolts are there, do not assume they are adequate for baseplate mounting. Always use hardware supplied in the hardware kit and existing hardware specified in the Baseplate Installation Instructions.

Attachment Tab Height: 23 3/4"
Attachment Tab Width: 20"

Bolt Torque Specifications
Torque in Foot-Pounds per Metric Bolts

Bolt Size	Grade 8.8	Grade 10.9
6MM	6	8
8MM	16	22
10MM	31	40
12MM	54	70
14MM	89	117

Confirm the towability and pre-towing procedures for your vehicle with the owner's manual or contact the vehicle's manufacturer for specific towing procedures.

Bolt Torque Specifications
Torque in Foot-Pounds per Inch Bolts

Bolt Size	Grade 5	Grade 8
1/4"	10	14
5/16"	19	29
3/8"	33	47
7/16"	54	78
1/2"	78	119
5/8"	154	230



! WARNING

Failure to read and follow these instructions could result in separation of the towed vehicle from the tow bar, causing property damage, loss of towed vehicle, personal injury or death.

BX2319

2005-09 Hyundai Tucson

Installation Instructions

Parts List

Ref. No.	Qty.	Part #	Description
1	1	61-6128	Weldment, Baseplate, BX2319
2	4	61-5208	Weldment, 3/8"-16 Nut Plate, w/ 14" Wire
3	4	201-0440	3/8-16 x 1 1/2" Hex Bolt, Grd. 5, ZP
4	4	203-0010	3/8" Lock Washer, ZP
5	1	201-0702	6MM-1 x 45MM Hex Bolt, Grd. 8.8 ZP
6	1	203-0009	5/16" Lock Washer, ZP
7	2	203-0002	5/16" Flat Washer, ZP
8	1	106-0101	Pipe, 3/8 Sch 40 x 1 Inch
9	3	201-0418	8MM-1.25 x 35MM Hex Bolt, Grd. 8.8, ZP
10	3	203-0102	8MM Lock Washer, ZP
11	2	201-0553	1/4-20 x 1/2 Hx. Wshd, Type F Screw
12	2	201-0192	#10-32 x 1/2 Slot, Rd. Hd. Screw
13	2	203-0054	#10 Lock Washer
14	2	202-0047	#10-32 Hex Nut
15	2	101-5822	Adapter, 4 Way Connector
16	2	62-3468	Attachment, Assembly, SF/ SB (R)
	2	226-0046	Baseplate Safety Cable, 36" CL III (NS)
	2	229-0359	Quicklink, 3/8, ZP (Not Shown)
	2	290-0437	Receiver, Cap Plug (BLK) (Not Shown)

Tools Required

8MM Socket	Utility Knife
10MM Socket	Vise Grip
12MM Socket	Reciprocating Saw
13MM Socket	13/32" Drill Bit
9/16" Socket	1 1/4" Hole Saw
Loctite Red	Diagonal Cutters

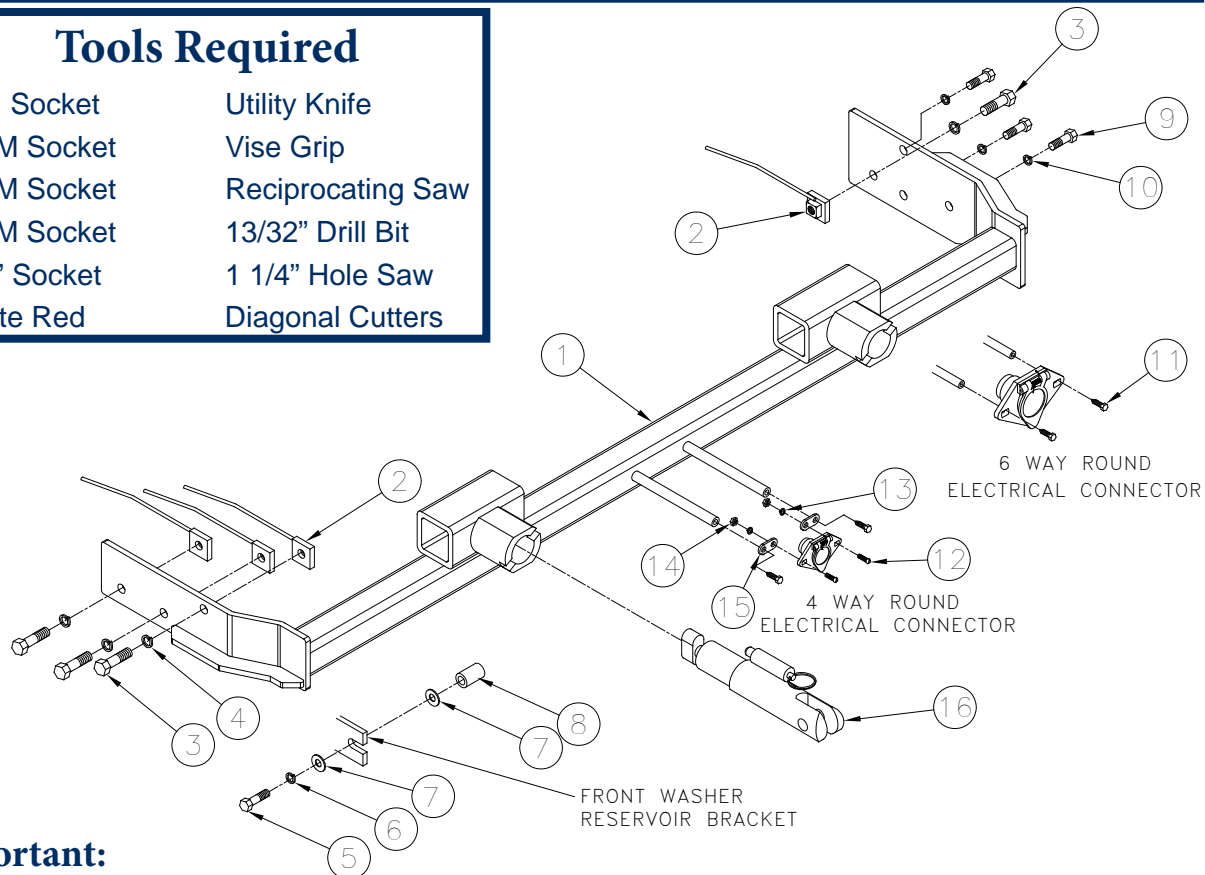

Important:

Use only genuine factory replacement parts on your baseplate. Do NOT substitute homemade or non-typical parts. If a bolt is lost or in need of replacement, for your safety and the preservation of your baseplate, be sure to use a replacement bolt of the same grade. In most cases it will be Grade 5—please reference the parts list above. Replacement parts may be ordered through your nearest Blue Ox® dealer or distributor, or call our Customer Care Team at (402)385-3051 or toll free (888) 425-5382.

BX2321

2005-09 Hyundai Tucson

Installation Instructions

Attachment Tabs:

Motorhome mount tow bars are recommended for use with this baseplate. Due to the design of the removable tabs, the RangeFinderII, Adventurer, and Ambassador tow bars can not be used. The Acclaim tow bar may be used, but will not fold and store on the front of the vehicle. Adapters, except the BX8833 and BX88151, can not be used with this baseplate.

Instructions:

The front fascia, air baffle and windshield washer reservoir are removed and reinstalled during baseplate installation. Drilling is required. Trimming of the air dam is required.

The dimensional variations between otherwise identical vehicles can be considerable. Although the baseplate was designed for easy installation, it may be necessary to tailor the baseplate slightly to compensate for auto manufacturer's tolerances. These minor adjustments may include filing a hole slightly, bending electrical rods, and/ or bending end plates.

The BX8869 Bulb and Socket Wiring Kit is recommended for this vehicle.

Installation Instructions:



1. Remove the five push pins from the top edge of fascia between head lights.

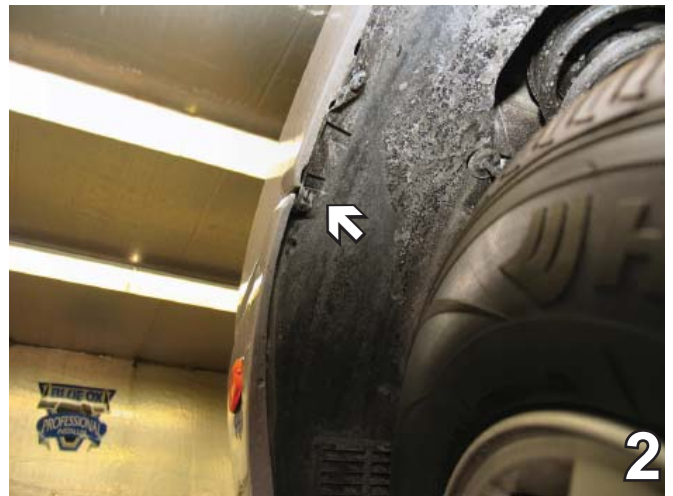

2. Remove the metric bolt on the upper corner of fascia just forward of front tire with the 8MM socket, both sides.

BX2319
2005-09 Hyundai Tucson
Installation Instructions



3. Remove the Phillips head push pin from lower corner of fascia just forward of front tire with the Phillips screw driver, both sides.

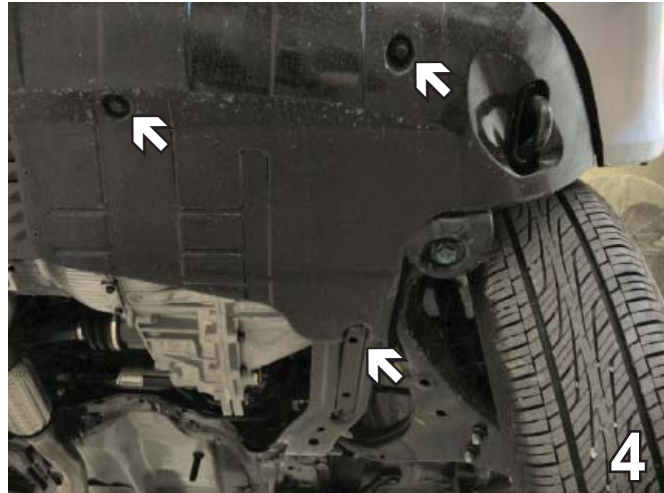

4. Remove the two metric bolts from the belly pan just inboard of the tie down brackets with the 12MM socket, both sides. Remove the Phillips head push pin, both sides (driver's side is shown).

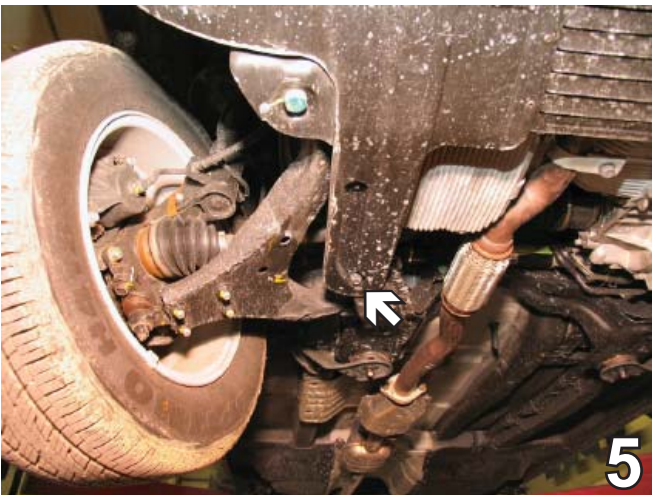

5. Passenger's side of the belly pan will have an additional metric bolt further back of the push pin that needs to be removed with the 12MM socket, and set belly pan aside.



6. Remove Phillips head push pin on the lower edge of fascia, pull fascia forward, unplug all electrical connections and set fascia aside.

BX2319

2005-09 Hyundai Tucson

Installation Instructions



7. Using the 12MM socket, remove the two front metric bolts from the air baffle on the driver's side.



8. Remove the metric bolt from between the air baffle and wheel well using the 12MM socket, pull the air baffle down to disconnect from upper tube and set aside.

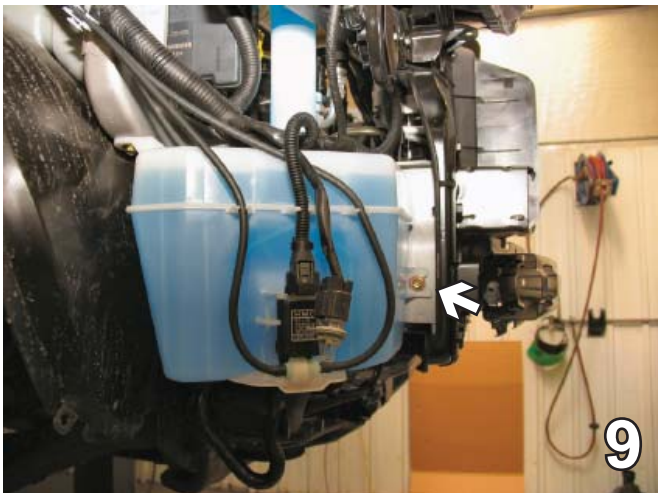

9. Remove front metric bolt from the washer reservoir on the passenger's side using the 10MM socket. Remove one Phillips screw, pull reservoir down, unplug electrical connections, disconnect and plug water lines, set aside.



10. Separate the wheel well from the back side of the reservoir and remove the two metric bolts using the 10MM socket, pull reservoir down, unplug electrical connections, disconnect and plug water lines, set aside.



11. Remove the rubber plugs from the side of the frame rail, both sides. Mark the front edge of frame cap on the driver's side level with the top of frame rail. Repeat on passenger's side (driver's side shown).

BX2319

2005-09 Hyundai Tucson

Installation Instructions

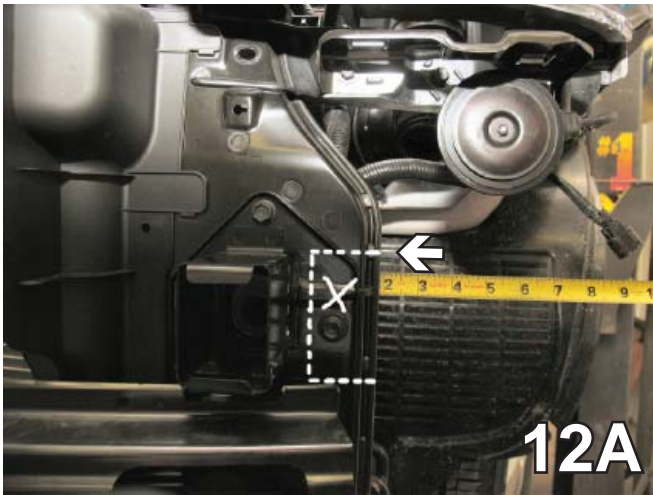

12. On driver's side, draw a horizontal line on the front side of the frame cap in toward the center of the vehicle to the outside edge of frame rail, parallel with the marking in step 11. Measure and mark 3 1/2 inches down as shown in the right photo. Using the reciprocating saw, make the two horizontal cuts first and then the vertical cut flush on the outside edge of the frame rail being careful not to cut into frame rail. **DO NOT CUT INTO FRAME RAIL.** Be sure to paint cut edges of end cap as a rust prevention.

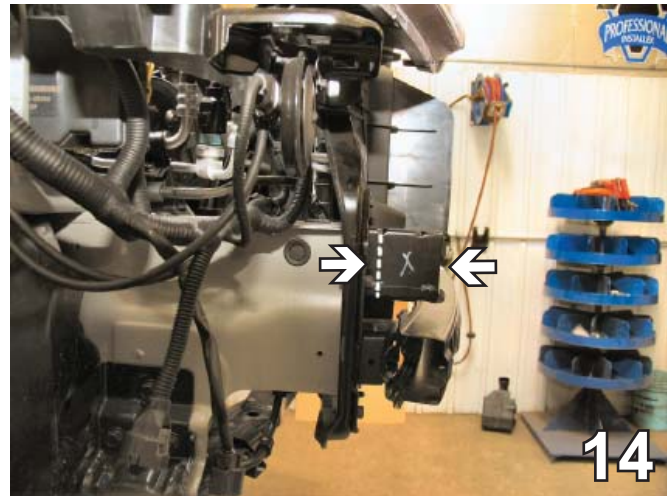
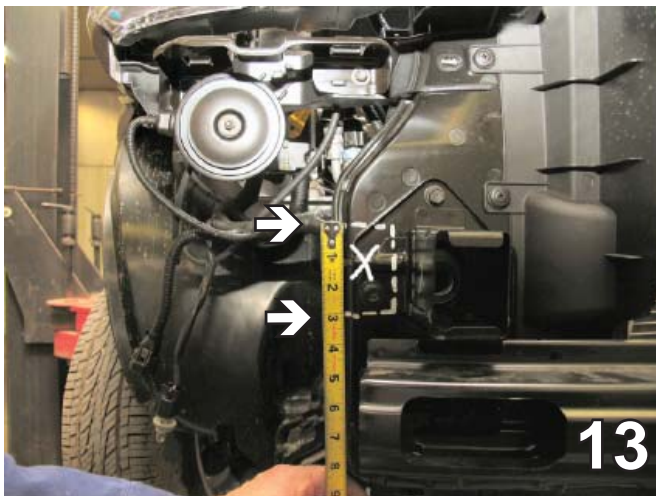

13. On driver's side, draw a horizontal line on the front side of the frame cap in toward the center of the vehicle to the outside edge of frame rail, parallel with the marking in step 11. Measure and mark 3 inches down, as shown in photo. Using the reciprocating saw, make the two horizontal cuts first and then the vertical cut flush on the outside edge of the frame rail being careful not to cut into frame rail. **DO NOT CUT INTO FRAME RAIL.** Be sure to paint cut edges of end cap as a rust prevention.

14. Measure and mark from the end of the frame extension 2 1/2" back with a marker. Remove this section from the frame extension with the reciprocating saw, both sides. Passenger's side is shown.

Using a good quality paint, spray cut edges of frame to prevent rusting.

BX2319
2005-09 Hyundai Tucson
Installation Instructions

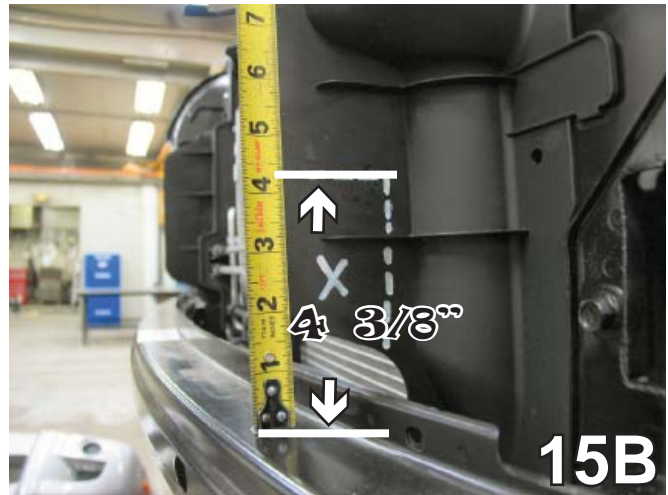
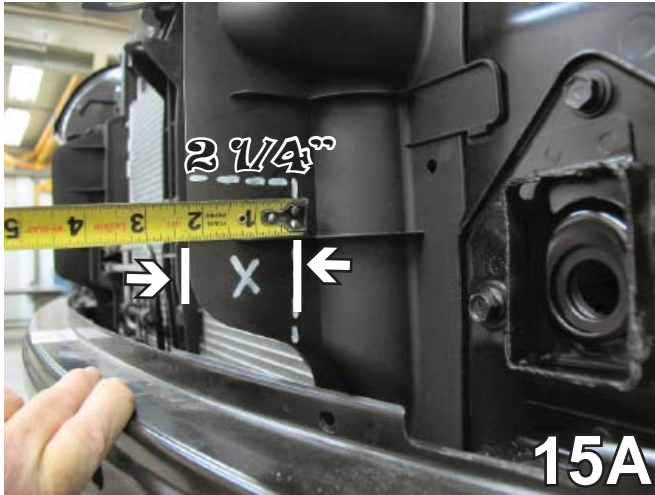

15. Measure and mark 2 1/4" horizontally from the front edge of air dam to the radiator and vertically 4 3/8" from the top of metal bumper to the air dam. Remove this portion of the air dam with the utility knife, both sides.

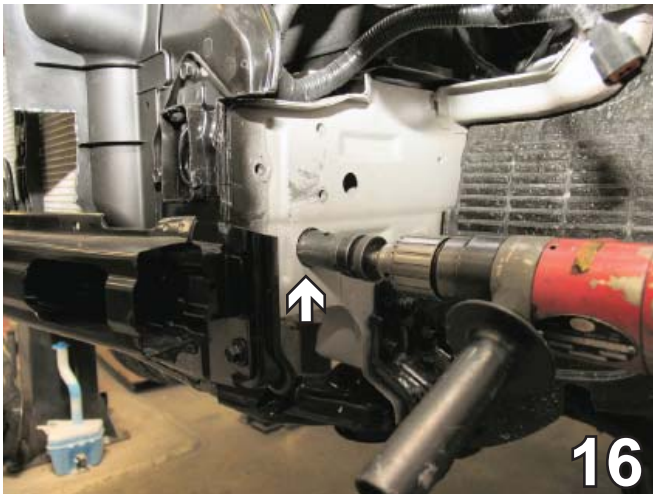

16. Using the 1 1/4" hole saw, cut an opening in the lower portion of the frame rail to use for wire nut installation, both sides as shown in photo.

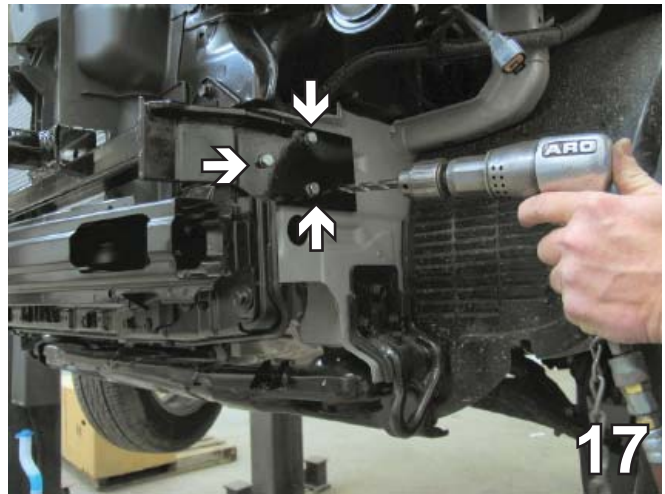

17. Slide baseplate onto the frame to align the three existing holes on the driver's side, insert the 8MM-1.25 hex bolts and lock washers and tighten. **Keep baseplate level with the frame.** Using the baseplate as a template, drill the back hole on the driver's side with the 13/32" drill bit. Insert the 3/8" nut plate into the 1 1/4" hole to align with drilled hole, tighten the 3/8-16 hex bolt and lock washer into nut plate. **Be sure and use loctite red on all bolts before tightening. Tighten all bolts according to the torque chart in the General Instruction sheet.**

****BE SURE TO USE LOCTITE® RED ON ALL BOLTS BEFORE TIGHTENING. TIGHTEN ALL BOLTS ACCORDING TO THE TORQUE CHART ON THE FRONT PAGE OF THESE INSTRUCTIONS OR ON PAGE 3 OF THE BASEPLATE TOWING GENERAL INSTRUCTIONS.**

BX2319

2005-09 Hyundai Tucson

Installation Instructions



18. Adjust passenger's side on baseplate to maintain the same distance from the frame end cap to the front edge on baseplate of both sides. Using the baseplate as a template, drill the holes on the passenger's side with the 13/32" drill bit. Insert the 3/8" nut plate into the 1 1/4" hole to align with drilled hole, tighten the 3/8-16 hex bolt and lock washer into nut plate. **Be sure and use loctite red on all bolts before tightening. Tighten all bolts according to the torque chart in the General Instruction sheet.**

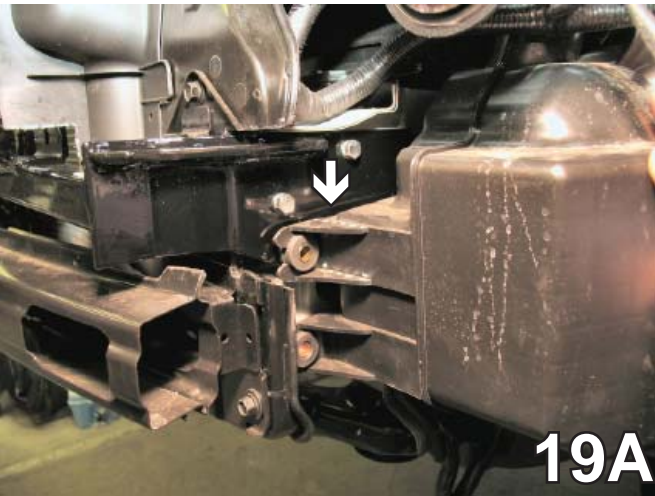

19. Using the utility knife, cut and remove the front upper bolt bracket from the air baffle flush with the main body. Reinstall air baffle on driver's side.

20. Reinstall washer reservoir on the passenger's side using the 6MM hex bolt, 5/16" lock washer, 5/16" flat washers and short piece of pipe as shown in the drawing page 2. **Be sure all electrical components and hoses are plugged in properly.**



BX2319

2005-09 Hyundai Tucson

Installation Instructions



21. While holding the fascia as close to its original position as possible, slide the electrical rods through grille openings. If the electrical rods do not come through openings properly, bend electrical rods with a short piece of pipe. Try to maintain 2 7/8" distance between them. Cut the grille around the outside edge of the removable tab receivers using the diagonal cutters, both sides. Reinstall fascia and belly pan. **Be sure all electrical components and hoses are plugged in properly.**
22. The dimensional variations between otherwise identical cars can be considerable. While the baseplate was designed for easy installation, it may be necessary to tailor the baseplate slightly to compensate for auto manufacturers' tolerances. These minor adjustments may include filing a hole slightly, bending electrical rods, adding shims and/or bending endplates.
23. Install the tow bar and safety cables according to the instructions included in their packages. Be sure the safety cables do not rub against any hoses or moving parts.
24. Do **not** substitute other devices if the tow bar pin and clip are lost.
25. **DEALER OR INSTALLER: BE CERTAIN THE USER RECEIVES THE INSTRUCTION SHEET.**

Be sure that **ALL** electrical connections are plugged in properly and functioning **BEFORE** installing the fascia.

Install the tow bar and safety cables according to the instructions when demonstrating this to the customer,. Be sure to include all the contents and packages.

Do **NOT** substitute other devices if the tow bar pins and clips are misplaced.

BX2319

2005-09 Hyundai Tucson

Installation Instructions

DEALER or INSTALLER:

Be certain the user receives the instruction sheets for their products.



CUSTOMER SERVICE COMMITMENT

Blue Ox is committed to providing you with exceptional customer care throughout your lifetime with our products. Our team is here to assist you with any questions you may have regarding the performance of your product. Simply call 1-800-228-9289 and you can speak with our customer care team.

Additionally, please visit our website to see which rallies our Destination America team will be attending. For a nominal fee, our service technician will service your towing system to ensure it's in proper working condition. Also as a commitment to our customers, should you visit our factory you can stay at our full service Blue Ox campground at no charge along with enjoying a factory tour.

Again thank you for being our customer and for the confidence you have shown in the performance of our products. It is because of customers like you we enjoy the success we have today.



© 2007, 08, 09 Blue Ox
One Mill Road, Industrial Park
Pender, Nebraska 68047
Phone: (402) 385-3051
Fax: (402) 385-3360
www.blueox.us