



BX2333

2012 Hyundai Accent (No Foglights) Installation Instructions

Serial Number

Please read BOTH these Installation Instructions and the General Towing Instructions before attempting to install or operate this equipment.

- Blue Ox® towing products and accessories are intended to be installed by Blue Ox® Dealers who are familiar with our products and have the equipment and knowledge to do “fit work”. When necessary, Blue Ox® Dealers can be found at www.blueox.com or by contacting our Customer Care Department at (402) 385-3051.
- Many Blue Ox® Baseplates are designed to use existing holes and hardware to mount the baseplate to the towed vehicle. Even though bolts are there, do not assume they are adequate for baseplate mounting. Always use hardware supplied in the hardware kit or existing hardware specified in the Baseplate Installation Instructions.

Attachment Tab Height: 14”
Attachment Tab Width: 25-1/2”

Bolt Torque Specifications
Torque in Foot-Pounds for Metric Bolts

Bolt Size	Grade 8.8	Grade 10.9
6MM	6	8
8MM	16	22
10MM	31	40
12MM	54	70
14MM	89	117

Confirm the towability and pre-towing procedures for your vehicle with the owner’s manual or contact the vehicle’s manufacturer for specific towing procedures.

Bolt Torque Specifications
Torque in Foot-Pounds for Inch Bolts

Bolt Size	Grade 5	Grade 8
1/4”	10	14
5/16”	19	29
3/8”	33	47
7/16”	54	78
1/2”	78	119
5/8”	154	230



If the front of your vehicle looks different than this, call us at (402) 385-3051.

! WARNING

Failure to read and follow these instructions could result in separation of the towed vehicle from the tow bar, causing property damage, loss of towed vehicle, personal injury or death.

BX2333

2012 Hyundai Accent (No Foglights)

Installation Instructions

Tools Required		
10MM Socket	12MM Socket	7/16" Wrench
9/16" Socket	Large Vise Grip	Flat Screwdriver
Phillips Screwdriver	Tape Measure	Utility Knife
Torque Wrench	Drill	1/4" Drill Bit
13/32" Drill Bit	1-1/4" Hole Saw	Reciprocating Saw
Hammer	Loctite® RED	

Item No.	Part No.	Description	Qty.
1.....	61-6947.....	BX2333 Baseplate.....	1
2.....	61-5208.....	3/8"-16 Nut Plate with 14" Wire.....	8
3.....	62-3468.....	Attachment Tab.....	2
4.....	201-0655.....	6MM-1.0 x 30MM Hex Head Bolt, Grade 8.8, ZP.....	1
5.....	201-0368.....	3/8"-16 x 1-1/4" Hex Head Bolt, Grade 5, ZP.....	8
6.....	203-0003.....	3/8" Flat Washer, ZP.....	8
7.....	203-0010.....	3/8" Lock washer, ZP.....	8
8.....	201-0702.....	6MM-1.0 x 45MM Hex Head Bolt, Grade 8.8.....	1
9.....	201-0050.....	1/4"-20 x 3/4" Hex Head Bolt, Grade 5, ZP.....	2
10.....	202-0069.....	1/4"-20 Hex Flange Whiz Lock Nut, ZP.....	2
11.....	201-0321.....	1/4"-20 x 2-1/2" Hex Head Bolt, Grade 5, ZP.....	1
12.....	102-7056.....	Breakaway Bracket.....	1
13.....	202-0102.....	1/4"-20 Hex Nylon Nut, ZP.....	1
14.....	202-0047.....	#10-32 Hex Nut.....	2
15.....	203-0054.....	#10 Lock Washer.....	2
16.....	101-5822.....	4 Way Connector Adapter.....	2
17.....	201-0553.....	1/4"-20 x 1/2" Hex Wshd Screw, Type F, ZP.....	2
18.....	201-0192.....	#10-32 1/2" Slotted Round Head Screw.....	2
19.....	226-0046.....	Class III Safety Cables.....	2
20.....	229-0359.....	3/8" Quicklink, ZP.....	2
21.....	290-0437.....	Black Cap Plug.....	2

BE SURE TO USE LOCTITE® RED ON ALL BOLTS BEFORE TIGHTENING. TIGHTEN ALL BOLTS ACCORDING TO THE TORQUE CHART ON THE FRONT PAGE OF THESE INSTRUCTIONS OR ON PAGE 3 OF THE BASEPLATE TOWING GENERAL INSTRUCTIONS.

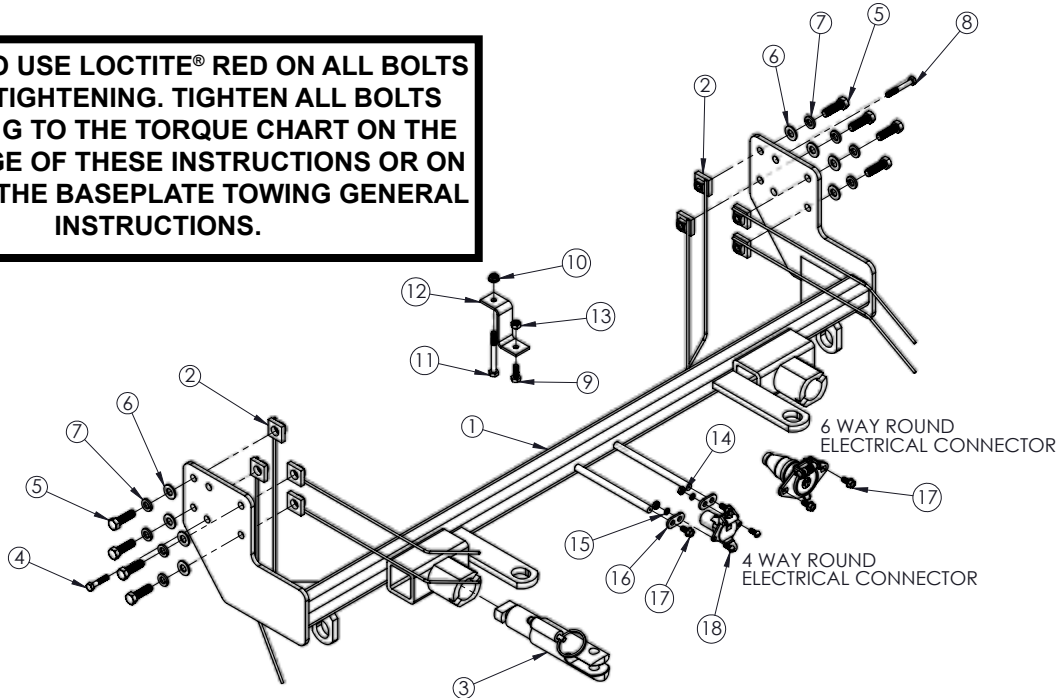

BX2333
2012 Hyundai Accent (No Foglights)
Installation Instructions

Attachment Tabs: Due to the design of the removable tabs, the RangeFinderII tow bar can not be used. Adapters, except the BX8833 and BX88151, can not be used with this baseplate.

Installation Notes: The radiator cover, fascia, horn, air baffle, washer reservoir, and metal bumper are removed during installation. Trimming is required. Drilling is required.

The dimensional variations between otherwise identical vehicles can be considerable. While the baseplate was designed for easy installation, it may be necessary to tailor the baseplate slightly to compensate for auto manufacturer's tolerances. These minor adjustments may include filing a hole slightly, bending electrical rods or bending end plates.

The BX8869 Bulb and Socket Wiring Kit is recommended for this vehicle.

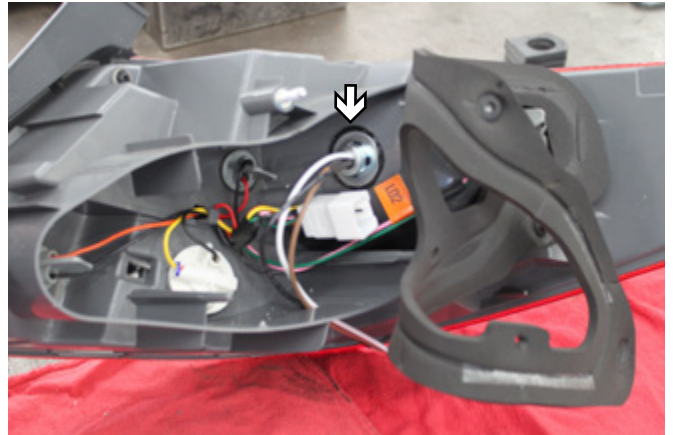

Possible location for the Bulb and Socket Wiring Kit (BX8869).

Do not use the towed vehicle for storing luggage, equipment, etc. This may cause you to exceed the towing capacity of the tow bar, baseplate, and its accessories.

Installation Instructions

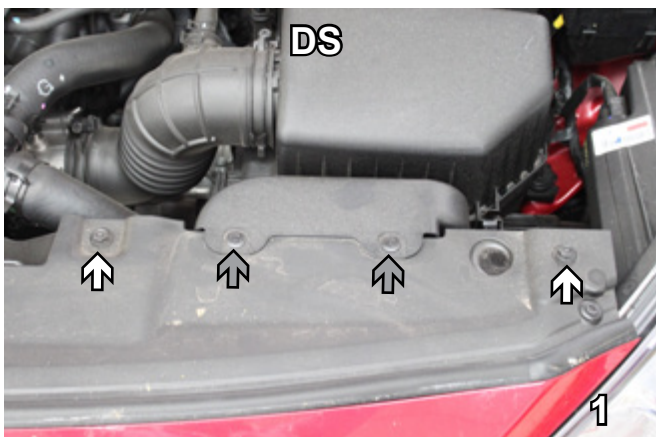

1. To remove radiator cover, with 10MM socket, remove 4 bolts (white arrows - 2 per side). To remove additional piece connected to the radiator cover, push in on the push pins and lift up to remove (gray arrows). Set radiator cover in its entirety along with bolts and push pins aside to be reinstalled later.

BX2333
2012 Hyundai Accent (No Foglights)
Installation Instructions



2. In front of tire, with a 10MM socket, remove bolt (white arrow). Do this to both sides. Set bolt aside to be reinstalled later.

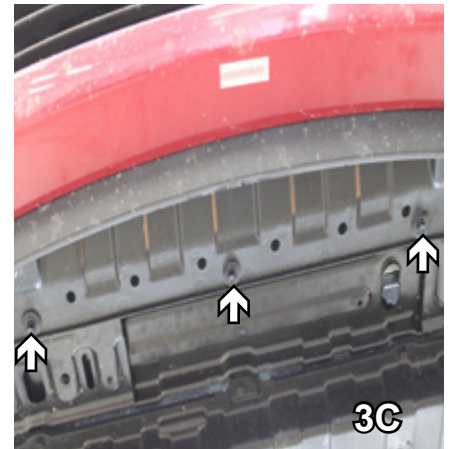

3. Under fascia, with Phillips screwdriver, remove 2 push pins from each side (3A and 3B). With a 10MM socket, underneath the fascia, toward the middle, remove 3 bolts (3C). Set push pins and bolts aside to be reinstalled later.



4. To remove fascia, lift up and pull out between the front tire and headlight as shown in the above pictures. Do this to both sides. Set fascia carefully aside to be reinstalled later.

BX2333
2012 Hyundai Accent (No Foglights)
Installation Instructions

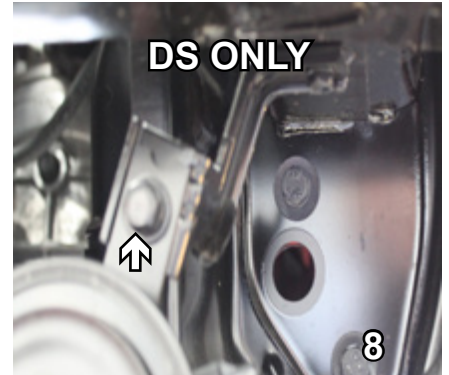
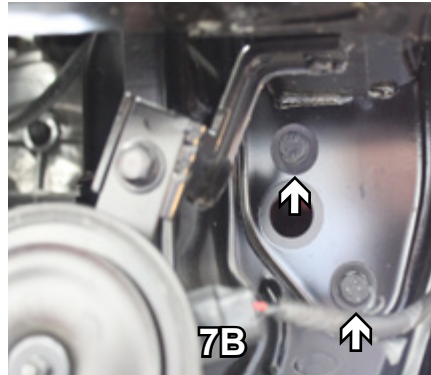
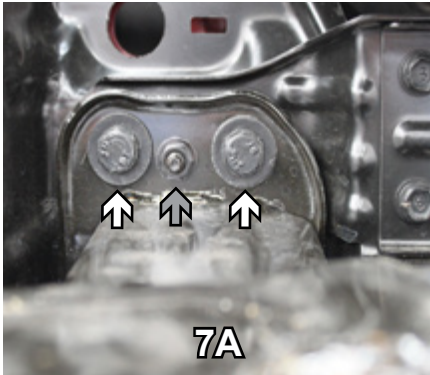

7. To remove metal bumper, with a 12MM socket, remove 2 bolts from top and bottom of metal bumper as shown in picture 7A and 7B (white arrows). With a 10MM socket, remove the bolt in the middle on top of the metal bumper as shown in picture 7A (gray arrow). Do this to both sides. Set bumper and bolts aside to be reinstalled later.
8. To remove horn on driver's side only, with a 10MM socket, remove bolt as shown in picture 8. Set horn and bolt aside to be reinstalled later.

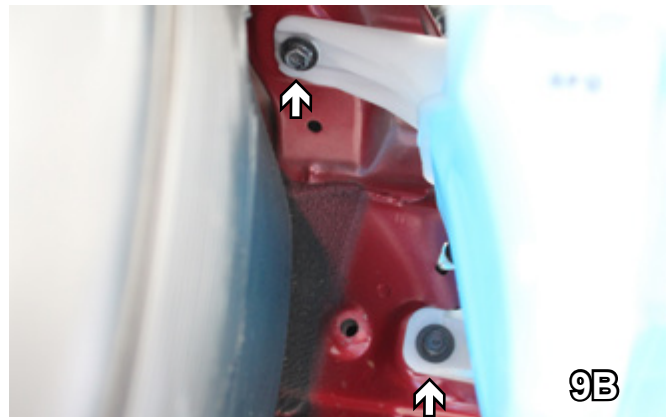
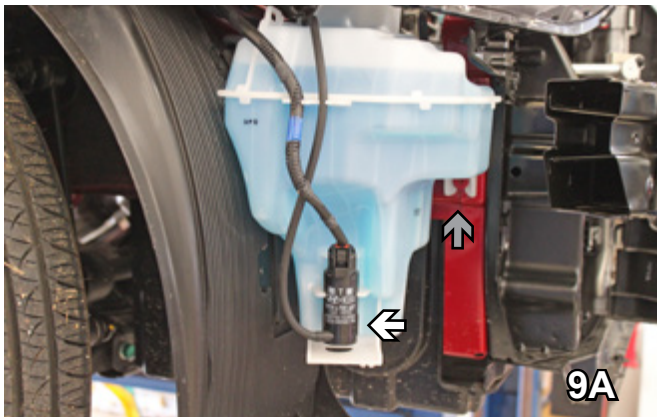

9. To remove washer reservoir on passenger's side, you must first unplug the electrical connections, disconnect and plug the fluid lines. (9A-white arrow). Using a 10MM socket, remove the 2 bolts from the back of the washer reservoir (9B). Set bolts aside to be reinstalled later. Slide the washer reservoir up and over the clip connection (shown in 9A-gray arrow). Set washer reservoir aside to be reinstalled later. With Phillips screwdriver, remove screw shown in 9A (gray arrow). This screw will be replaced with a 6MM-1.0 x 30MM hex bolt.

BX2333
2012 Hyundai Accent (No Foglights)
Installation Instructions

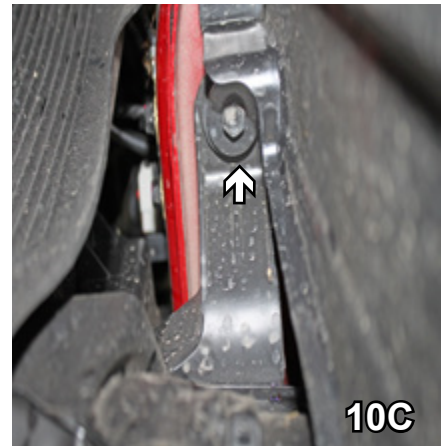
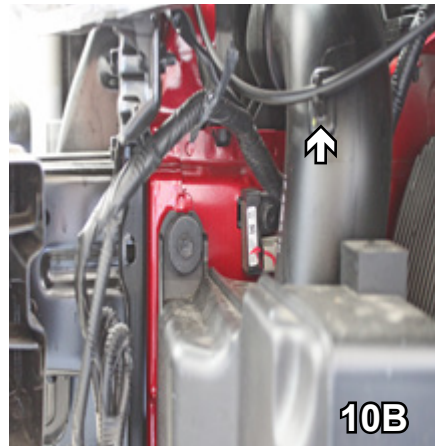
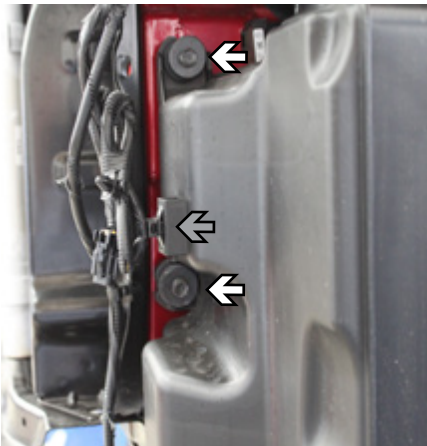

10. To remove air baffle on driver's side only, remove push pin on front of air baffle (10A - gray arrow) and with a 10MM socket, remove two bolts at the front of the air baffle as seen in 10A - white arrow. Disconnect hose from air baffle as shown in picture 10B. Underneath fascia in front of the tire, with 10MM socket, remove bolt shown in picture 10C. Set bolts, push pin, and air baffle aside to be reinstalled later.

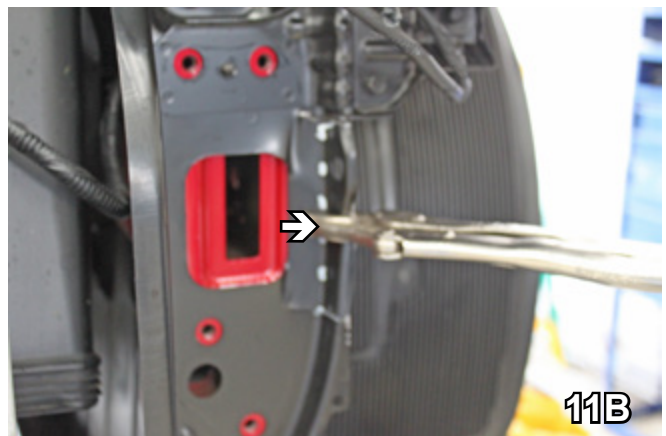
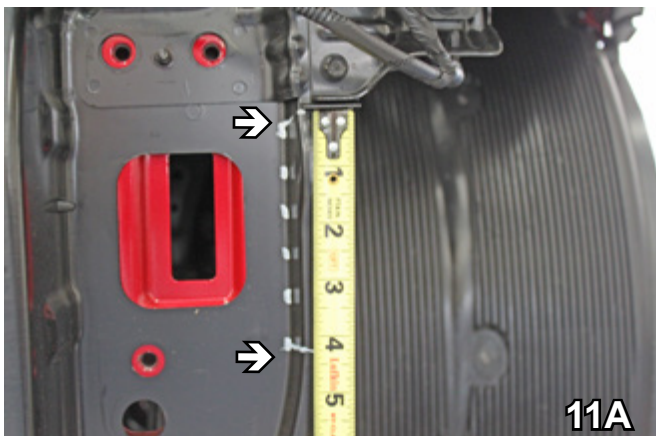

11. With reciprocating saw, cut into upper bumper guard (flush with metal brace) where indicated on 11A. The 2 cuts will be 4-1/4" apart. After cuts have been made, with large vise grips, toggle the cut area back and forth until it breaks free (11B). Do this to both sides.

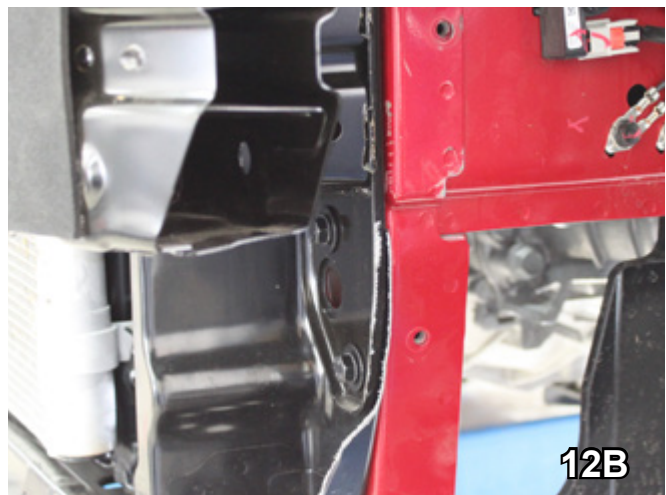
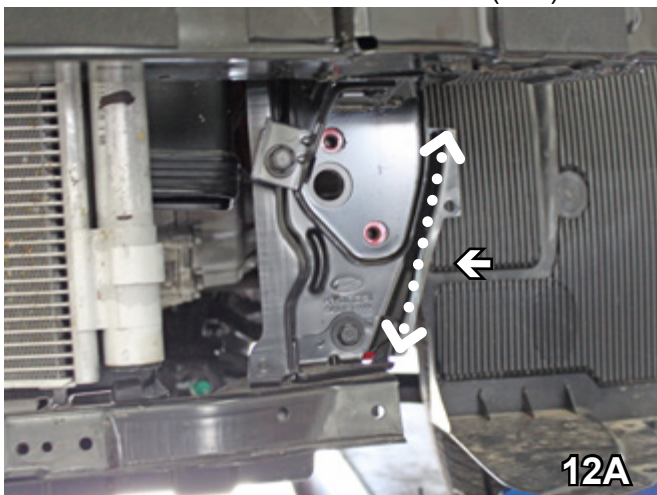

12. With reciprocating saw, cut lower bumper guard (flush with metal brace) where indicated on 12A. Do this to both sides. An example of the completed trimming is referenced in 12B. Reinstall bumper using existing bolts.

BX2333
2012 Hyundai Accent (No Foglights)
Installation Instructions

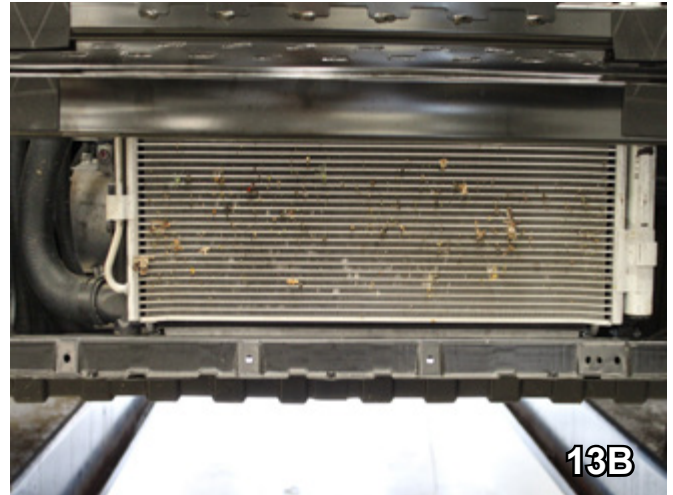

13. On passenger's side only, with utility knife, cut plastic guard even with bottom of metal bumper and remove it from the front of the vehicle (13A). The plastic guard will not be reinstalled. Front view of how the grille looks after plastic guard is removed is shown in 13B.

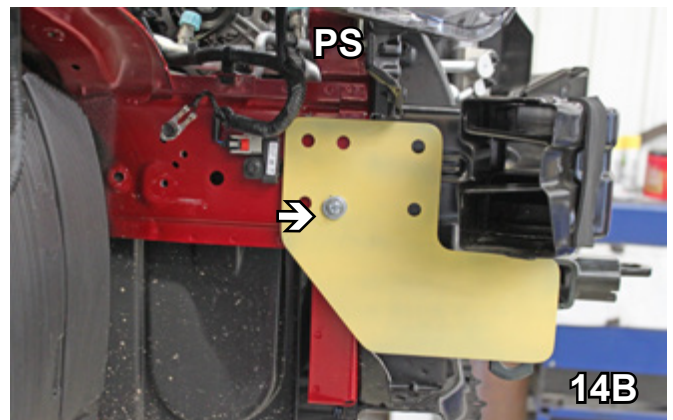
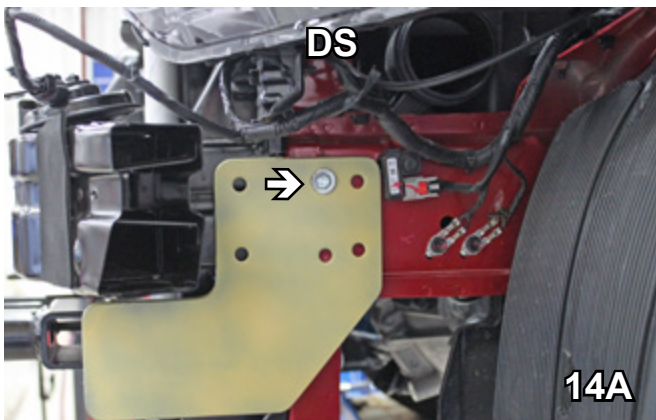

14. When mounting baseplate to the vehicle, use the existing holes on siderails to align and keep level as shown above. On driver's side, insert 6MM-1.00 x 45MM hex bolt into existing hole as shown in 14A with 3/8" flat washer and 3/8" lock washer. On passenger's side, insert 6MM-1.00 30MM hex bolt into existing hole as shown in 14B with 3/8" flat washer and 3/8" lock washer. (**Baseplate painted yellow for illustration. Actual baseplate will be powder-coat black.**)

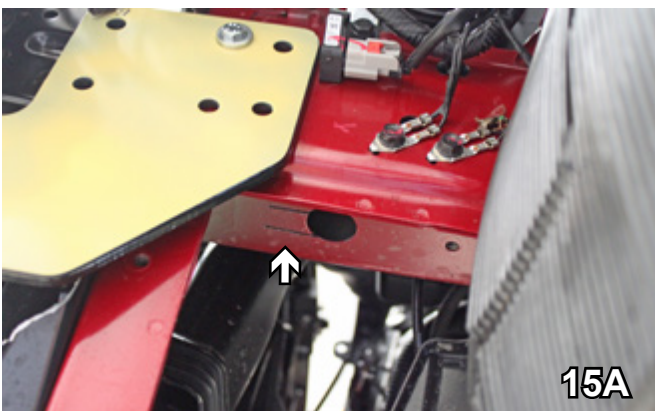

15. Underneath the framerail, with a reciprocating saw, make 2 horizontal cuts as shown in 15A (between 1" - 1 1/2" long). With a vise grip, bend the metal between the cuts to widen the opening underneath the framerail (15B). Do this to both sides. These openings will be used to insert the nut plates at a later point in the instructions.

BX2333
2012 Hyundai Accent (No Foglights)
Installation Instructions

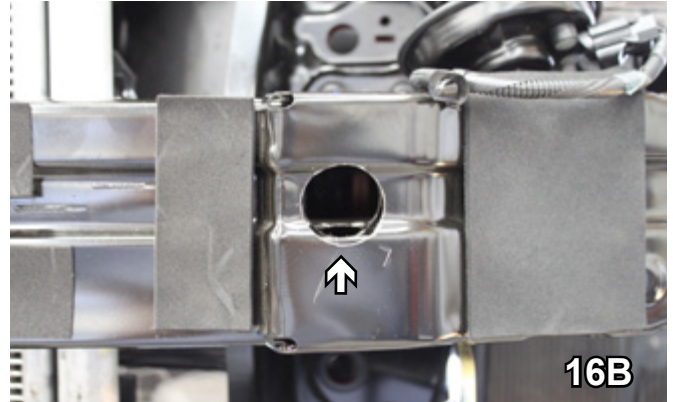
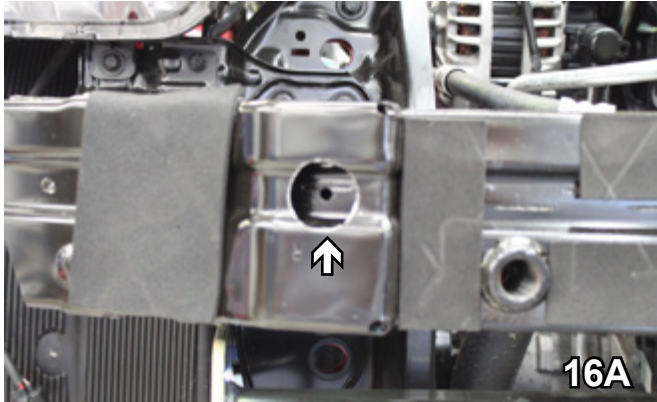

16. On the front of the bumper, toward the outer edge of the bumper, with a 1-1/4" hole saw, cut through the front 2 layers of the metal bumper (1st layer cut is shown in 16A - 2nd layer cut is shown in 16B). Do this to both sides. Nut plates will be inserted through these holes at a later point in the instructions.

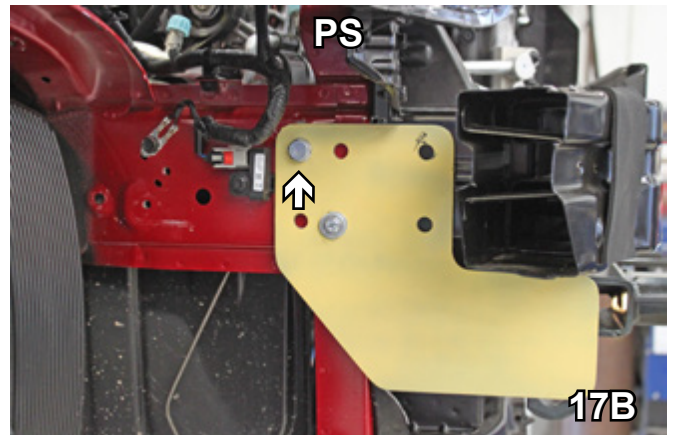
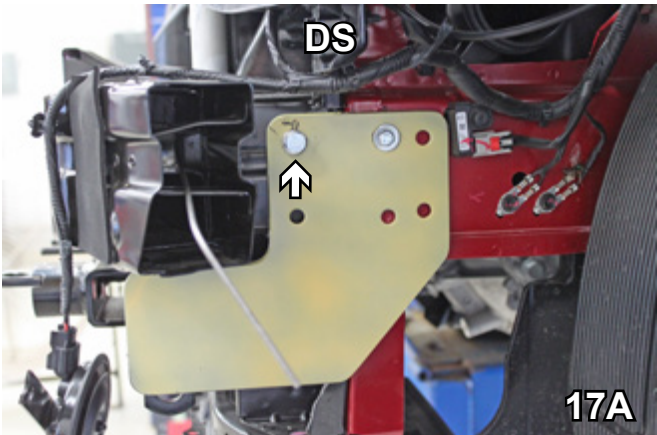

17. Using a 13/32" drill bit, drill top front hole on driver's side (17A) and top back hole on passenger's side (17B). Always ensure baseplate remains level. Insert 3/8"-16 x 1 1/4 hex bolt, 3/8" lock washer, 3/8" flat washer and 1/4"-20 x 1" x 1" nut plate into each drilled hole. **NOTE:** Nut plate for DS will be inserted through holes drilled in the front of the metal bumper (instruction #16). Nut plate for PS will be inserted through opening made underneath the frame rail (instruction #15). Tighten bolts with Loctite Red.

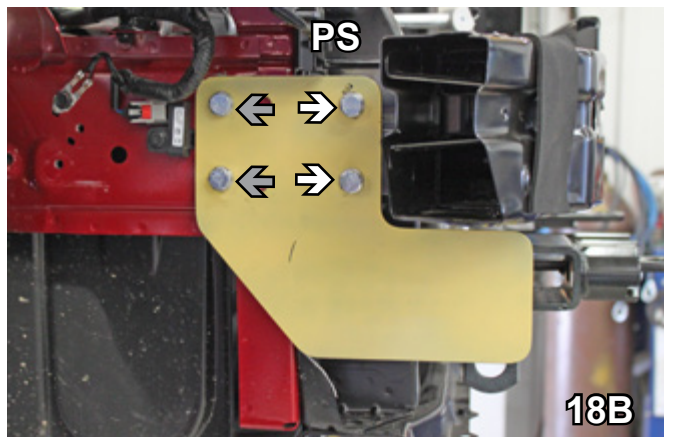
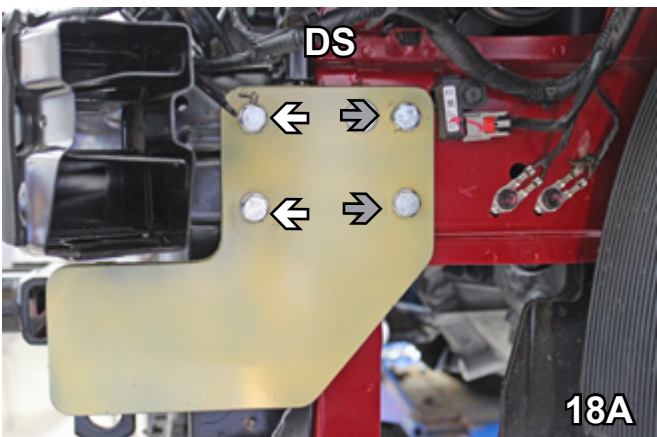

18. Using a 13/32" drill bit, drill remaining 3 holes for mounting baseplate. Do this to both sides. Insert 3/8"-16 x 1-1/4" hex bolt, 3/8" lock washer, 3/8" flat washer and 1/4"-20 x 1" x 1" nut plate into each drilled hole. **NOTE:** Nut plates for top and bottom front holes (white arrows) will be inserted through the holes drilled in the metal bumper. Nut plates for the top and bottom back holes (gray arrows) will be inserted through the opening made underneath the frame rail. Tighten bolts with Loctite Red.

BX2333
2012 Hyundai Accent (No Foglights)
Installation Instructions



19. Reinstall washer reservoir on passenger's side using existing bolts in the back of the reservoir (19A) and on the side of the reservoir, use 6MM-1.00 30MM hex bolt into existing hole with 3/8" flat washer and 3/8" lock washer (19B). Tighten bolts with Loctite Red. Reattach fluid lines and electrical connections.

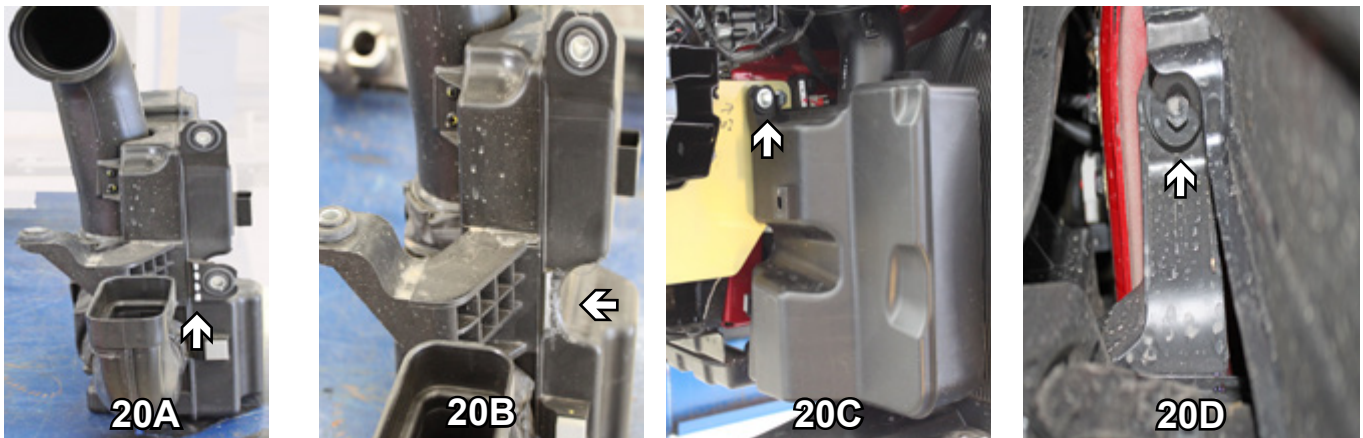

20. Trimming of the air baffle is required before reinstallation. With a utility knife, trim the lower bolt tab off of the air baffle as shown in 20A. A picture of the completed trimming is shown in 20B. Reinstall the air baffle on the driver's side using 6MM-1.00 x 45MM hex bolt with 3/8" flat washer and 3/8" lock washer for top bolt hole (20C) and existing bolt on the bottom side of the air baffle (20D). Tighten bolts with Loctite Red.



21. To reinstall the horn on driver's side, flatten the notch at the end of the horn bracket by tapping with a hammer (21A). Drill a 1/4" hole through the bottom of the metal bumper (21B). Insert 1/4"-20 x 3/4" hex bolt with 1/4"-20 hex flange whiz nut to attach horn bracket. Use existing bolt to attach horn to horn bracket (20C).

BX2333
2012 Hyundai Accent (No Foglights)
Installation Instructions

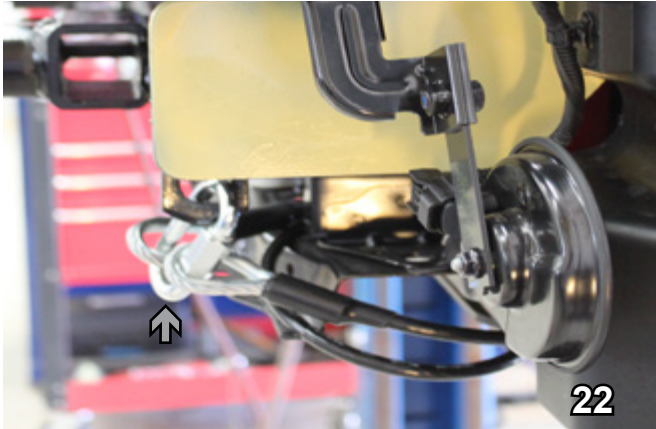

22. Attach the permanent baseplate safety cables to the provided convenience link on the baseplate (gray arrow). The photo above shows the recommended installation of the cables to frame of vehicle (white arrow). Additional options may interfere with suggested mounting; in this case secure the cables to a solid piece of the frame as described in the instructions included with the permanent baseplate safety cables. Be sure the safety cables do not rub against any hoses or moving parts. Do this to both sides of the vehicle.

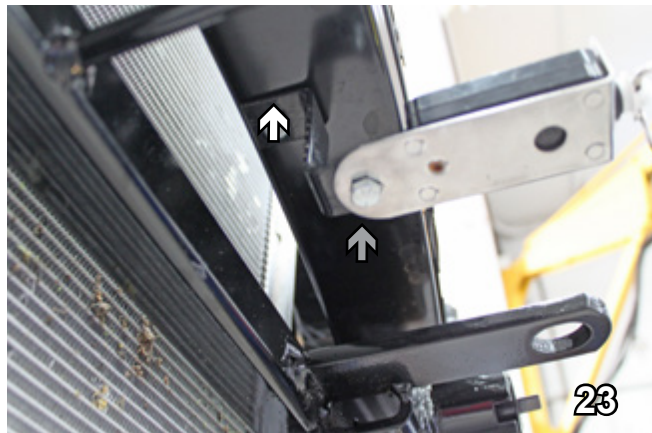

23. OPTIONAL: You can install the breakaway bracket and breakaway on either the driver's side or passenger's side of the vehicle. There will be an existing hole on the underside of the metal bumper. Once you have located this hole, drill out this hole with a 1/4" drill bit, making sure you penetrate both layers on the underside of the bumper. Insert 1/4"-20 x 2-1/2" hex bolt with 1/4"-20 hex flange whiz nut to secure the bracket (white arrow). Attach breakaway to the bracket with 1/4"-20 x 3/4" hex bolt with 1/4"-20 hex nyl nut (gray arrow).

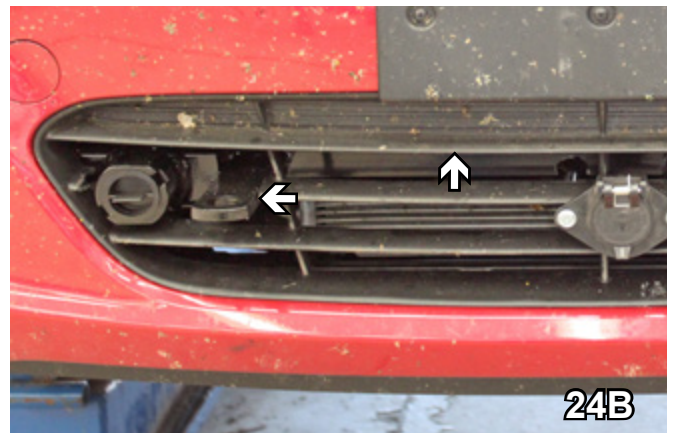

24. In order to accommodate attachment tabs through the fascia of the vehicle, with a utility knife, trim middle piece of fascia referenced in 24A. Do this to both sides of the vehicle. Picture of completed trimming shown in 24B.

BX2333
2012 Hyundai Accent (No Foglights)
Installation Instructions

25. Reinstall the radiator cover and fascia.

Install the tow bar and safety cables according to the instructions provided in their packages. When demonstrating this to the customer, be sure to include all the contents and packages.

Do **NOT** substitute other devices if the tow bar pins and clips are misplaced.



Shown with removable tabs installed.



Shown without removable tabs installed.

CUSTOMER SERVICE COMMITMENT

Blue Ox is committed to providing you with exceptional customer care throughout your lifetime with our products. Our team is here to assist you with any questions you may have regarding the performance of your product. Simply call (402) 385-3051 and you can speak with our customer care team.

Additionally, please visit our website to see which rallies our Destination America team will be attending. For a nominal fee, our service technician will service your towing system to ensure it's in proper working condition. Also, as a commitment to our customers, should you visit our factory, you can stay at our full service Blue Ox campground at no charge along with enjoying a factory tour.

Again, thank you for being our customer and for the confidence you have shown in the performance of our products. It is because of customers like you we enjoy the success we have today.

If the baseplate is in an accident, it must be replaced. DO NOT use it again! An accident can cause unseen damage and using it again could result in more damage or serious injury. DO NOT use the baseplate if it is damaged or missing parts.



© 2011 Blue Ox
One Mill Road, Industrial Park
Pender, Nebraska 68047
Phone: (402) 385-3051
Fax: (402) 385-3360
www.blueox.com