



BX2510 Installation Instructions 1996 Mazda MPV

This vehicle weighs over 3500 lbs and requires a Class III (5000 lb) rated tow bar, hitch, and accessories. Utilization of Blue Ox baseplates with any tow bar not approved by Automatic Equipment Mfg. Company invalidates the limited warranty.

1. Read the General Instruction Sheet included with this baseplate.
2. Remove the turn signal lights. There is a phillips head screw between the inside of the fender and the outside of the headlight. Unplug the wire and set the light aside.
3. Below the turn signal light is a gold plate. On the back side is a nut. Use a 10mm wrench to remove this nut on both sides.
4. In the top front of the fender wells there is a phillips screw and also on the bottom outside corner of the bumper there is a screw. Remove these on both sides.
5. On the front face of the bumper there are four bolts to remove. Two are in the fog light openings and two are in the outside corners of the grill opening.
6. Remove the plastic belly pan. There are 10 bolts holding it on. A 10mm wrench will fit the bolts. With the belly pan removed, pull the bumper cover straight ahead and off.
7. On each side of the van there are tie down brackets bolted to the frame with four bolts. Use a 12mm wrench and remove these brackets. Set the brackets and the bolts aside, they will not be used in the installation.
8. Bolt the end plates of the baseplate to the frame where the brackets were bolted. Apply Loctite to the bolts as you start them. When all bolts are started, tighten completely.
9. Replace the bumper. You may have to widen the grill opening slightly to allow the attachment tabs of the baseplate to come through the grill. If it is necessary to widen the grill, you can slit the plastic above and below the tabs and let the baseplate push the plastic out as you slide the bumper on.
10. Finish the installation by replacing the belly pan and the other hardware removed while taking off the bumper.
11. The dimensional variations between otherwise identical cars can be considerable. While the location and size of the holes in the baseplate were designed to allow for easy installation, it may be necessary to file a hole slightly to allow a bolt to clear.
12. Install the tow bar and safety cables according to the instructions included in their packages.
13. Do not substitute other devices if the tow bar pin and clip are lost.
14. DEALER OR INSTALLER: BE CERTAIN THE USER RECEIVES THE INSTRUCTION SHEET.

Tools Required

Phillips Screwdriver
13mm Wrench

10mm Wrench
Utility Knife

12 mm Wrench
Loctite Blue

Automatic

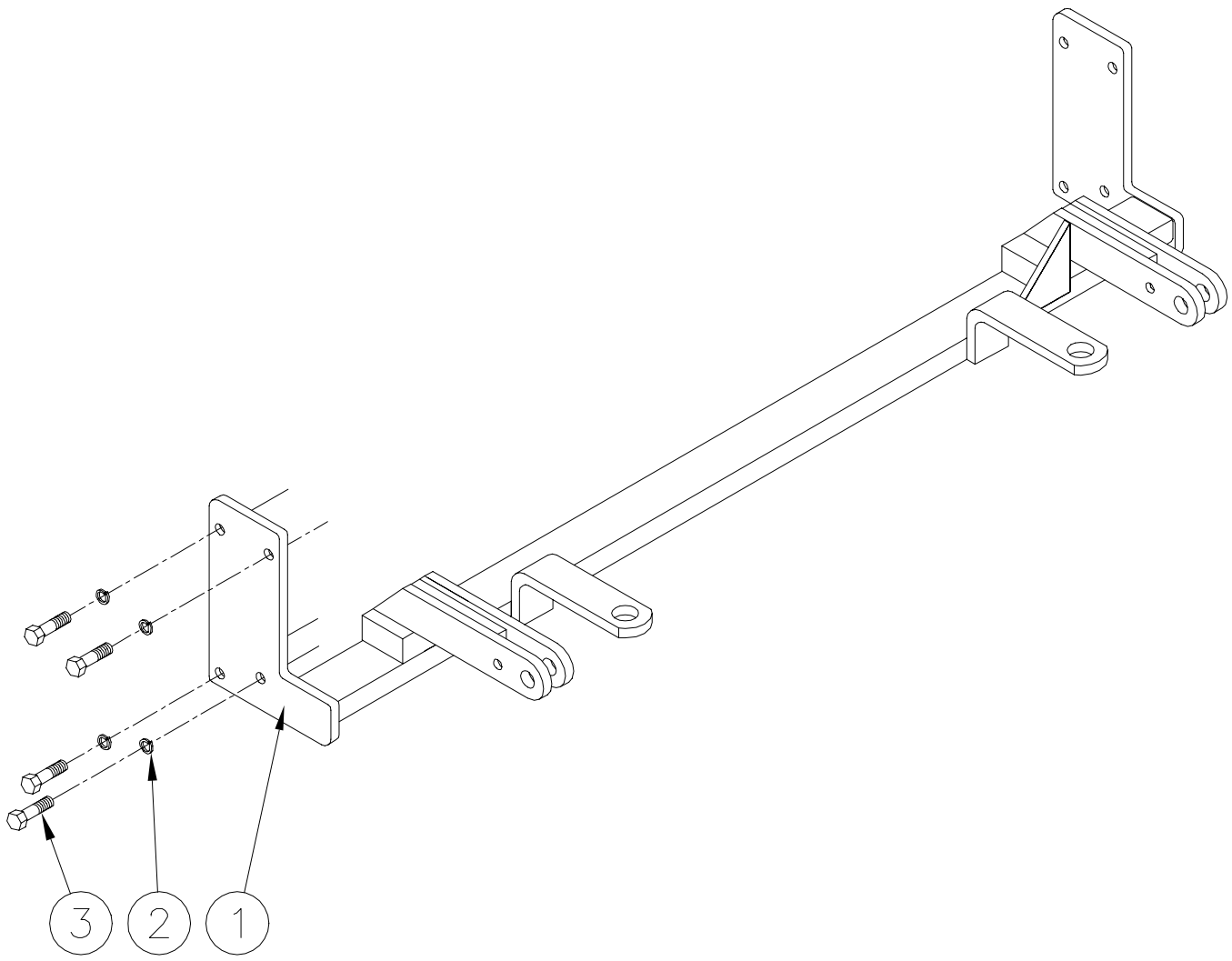

Parts List

Ref. No.	Qty.	Part No.	Description
1	1	61-4885	BX2510 Baseplate
2	8	203-0102	8mm Lock Washer
3	8	201-0446	8mm-1.25 x 30mm Hex Bolt, Grade 8.8