



Strong As An Ox™

BX2516 Installation Instructions 2002 Mazda Protege' 5

Serial No.

The license plate bracket, front fascia, and lower grill are removed for baseplate installation. Lower grill will need to be trimmed or left out. No drilling necessary. The BX8869 is available for the vehicle. Attachment Tabs are 24 inches center to center and a height of 14 inches.



1. Just inside of head lights, on the top side of grill, are two phillips head screws to remove.



2. Remove the four push pins from the top side of fascia.



3. Remove three phillips head push pins inside wheel well, just forward of front tires, both sides.



4. Using the 8MM socket, remove the three metric bolts on lower fascia corner, both sides.



5. Using the 7MM socket, remove the two metric bolts on fascia corner inside front fender, both sides.



6. Remove two metric bolts on the bottom side of fascia with the 10MM socket, both sides.



Strong As An Ox™



7. Locate electrical wiring and hoses for windshield washer reservoir and disconnect. (Note hose and electrical plug locations for reinstalling.)

8. Using the 10MM socket, remove the two metric bolts from windshield washer reservoir, set aside.



9. Using the 14MM socket, remove the four metric bolts from tow hook bracket, both sides. Hold tow hook bracket, items 2 and 1 to align with existing holes and tighten items 3 and 4 with the 17MM socket, according to drawing on last page. **Be sure and use loctite on all bolts before tightening.**

10. Reinstall windshield washer reservoir. Refer to step 7 for locations for electrical plug and hoses. **Optional: (1)** Replace fascia and cut lower grill opening as needed to allow attachment tabs to come through. **(2)** Set fascia on a soft surface face down, remove grill clips and grill, then reinstall fascia.

11. The dimensional variations between otherwise identical cars can be considerable. While the location and size of the holes in the baseplate were designed to allow for easy installation, it may be necessary to file a hole slightly to allow a bolt to clear.

12. Install the tow bar and safety cables according to the instructions included in their packages.

13. Do **not** substitute other devices if the tow bar pin and clip are lost.

14. **DEALER OR INSTALLER: BE CERTAIN THE USER RECEIVES THE INSTRUCTION SHEET.**



Tools Required

7MM Socket	14MM Socket	Loctite Blue
10MM Socket	17MM Socket	Vise Grips
Phillips Screw Driver		

Parts List

Ref. No.	Qty.	Part No.	Description
1	1	61-5763	Weldment, Base Plate, BX2516
2	4	102-6257	Spacer, BX2516
3	8	201-0495	10MM-1.25 X 45MM, Hex Bolt, Grd. 8.8,ZP
4	8	203-0104	10MM Lock Washer, ZP
5	4	203-0103	10MM Flat Washer, ZP
6	2	201-0553	1/4-20 x 1/2 Hx. Wshd, Type F Screw
7	2	201-0192	#10-32 x 1/2 Slot, Rd. Hd. Screw
8	2	203-0054	#10 Lock Washer
9	2	202-0047	#10-32 Hex Nut
10	2	101-5822	Adapter, 4 Way Connector
	2	226-0046	Baseplate Safety Cable, 36" CL III (Not Shown)
	2	229-0359	Quicklink, 3/8, ZP (Not Shown)
	1	290-0284	Wire Tie, Black, 5 7/8 Long (Not Shown)



Location for the BX8869 is on the bottom side of upper lens.

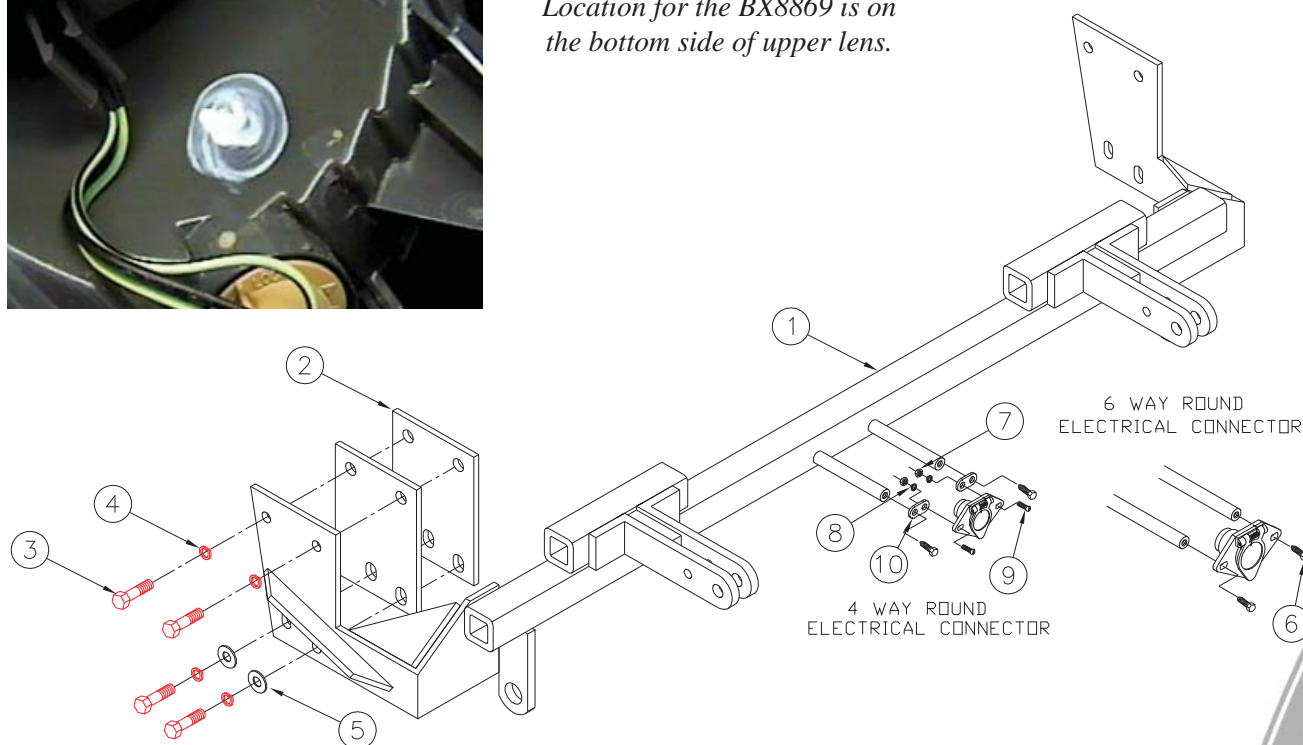

IMPORTANT: Use only genuine factory replacement parts on your Base Plate. Do not substitute homemade or nontypical parts. If a bolt is lost or in need of replacement, for your safety and the preservation of your Base Plate, be sure to use a replacement bolt of the same grade (Usually Grade 5, refer to parts list). Repair parts may be ordered through your nearest **Blue Ox** dealer or distributor.