



Baseplate Installation Instructions

BX2612 2008 Ford F-150 FX2 Sport (2WD) Installation Instructions

Serial Number

Please read BOTH these Installation Instructions and the General Towing Instructions before attempting to install or operate this equipment.

- Blue Ox® towing products and accessories are intended to be installed by Blue Ox® Dealers who are familiar with our products and have the equipment and knowledge to do “fit work”. When necessary, Blue Ox® Dealers can be found at www.blueox.us or by contacting our Customer Care Department at (888) 425-5382
- Many Blue Ox® Baseplates are designed to use existing holes and hardware to mount the baseplate to the towed vehicle. Even though bolts are there, do not assume they are adequate for baseplate mounting. Always use hardware supplied in the hardware kit or existing hardware specified in the Baseplate Installation Instructions.

Attachment Tab Height: 17”
Attachment Tab Width: 24”

Bolt Torque Specifications

Torque in Foot-Pounds for Metric Bolts

Bolt Size	Grade 8.8	Grade 10.9
6MM	6	8
8MM	16	22
10MM	31	40
12MM	54	70
14MM	89	117

Confirm the towability and pre-towing procedures for your vehicle with the owner’s manual or contact the vehicle’s manufacturer for specific towing procedures.

Bolt Torque Specifications

Torque in Foot-Pounds for Inch Bolts

Bolt Size	Grade 5	Grade 8
1/4”	10	14
5/16”	19	29
3/8”	33	47
7/16”	54	78
1/2”	78	119
5/8”	154	230



! WARNING

Failure to read and follow these instructions could result in separation of the towed vehicle from the tow bar, causing property damage, loss of towed vehicle, personal injury or death.

BX2612

2008 Ford F-150 FX2 Sport (2WD)

Installation Instructions

Parts List

Ref. No.	Qty.	Part #	Description
1	1	61-6654	Weldment, Baseplate, BX2612
2	4	61-4029	Weldment, 1/2 Nut Wire Common
3	8	201-0068	1/2-13 X 1 3/4 Hex Bolt Grd.5, ZP
4	8	203-0012	1/2 Lock Washer, ZP
5	4	202-0094	1/2-13 Hex Nylon Insert Lock Nut, ZP
6	2	201-0553	1/4-20 X 1/2 Hex.Washer.Type F Tcs, ZP
7	2	201-0192	10-32 X 1/2 Slot, RD. HD. Screw
8	2	203-0054	#10 Lock Washer
9	2	202-0047	#10-32 Hex Nut
10	2	101-5822	Adapter, 4 Way Connector
11	2	62-3468	Att. Tab Assembly Rem, SF/SB, 1 Hole
	2	226-0049	Baseplate Safety Cable, 36" CL IV (Not Shown)
	4	229-0512	Quicklink, 1/2, ZP (Not Shown)
	2	290-0437	Cap Plug, Black (Not Shown)

Tools Required

8MM Socket	Reciprocating Saw
10MM Socket	Tape Measure
21MM Socket	1" Hole Saw
3/4" Socket/Wrench	3/32" Drill Bit
3/8" Nut Driver	17/32" Drill Bit
Large Vise Grips	Loctite® RED

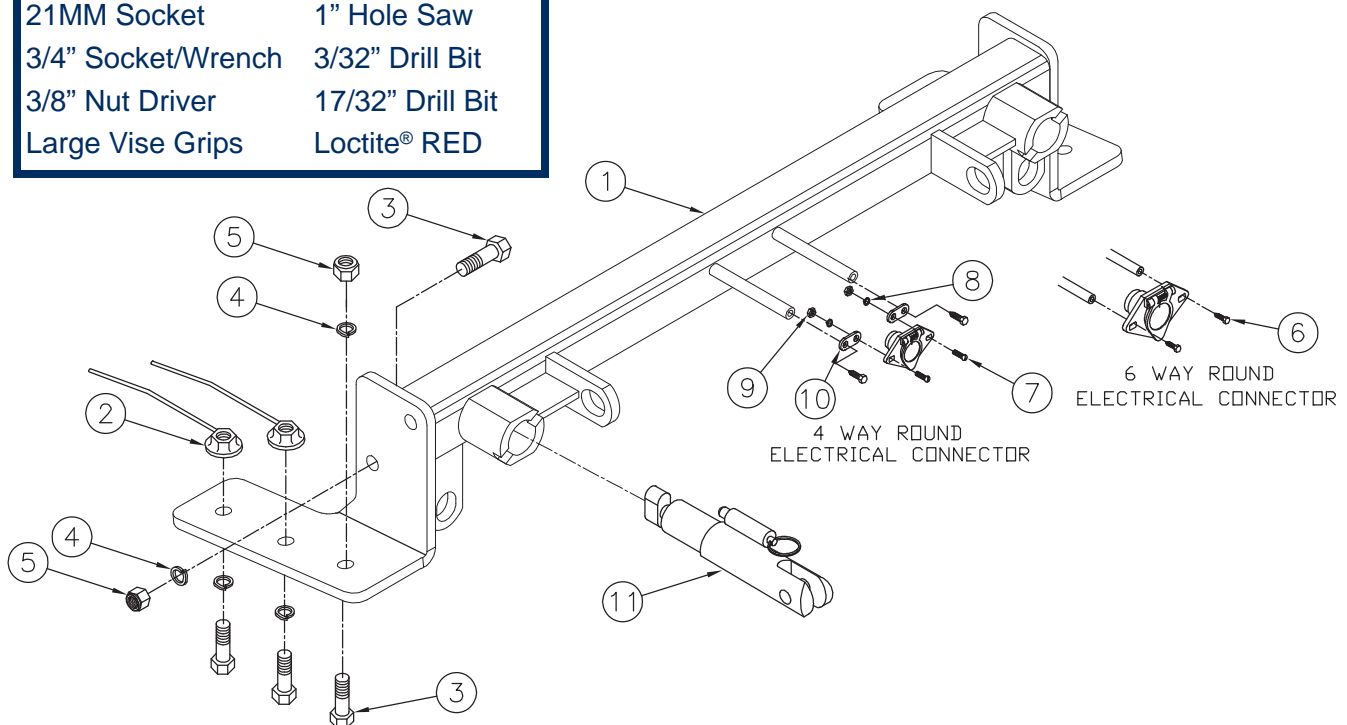

Important:

Use only genuine factory replacement parts on your baseplate. Do **NOT** substitute homemade or non-typical parts. If a bolt is lost or in need of replacement, for your safety and the preservation of your baseplate, be sure to use a replacement bolt of the same grade (In most cases it will be Grade 5, please reference the parts list above). Replacement parts may be ordered through your nearest Blue Ox® Dealer or Distributor.

BX2612 2008 Ford F-150 FX2 Sport (2WD) Installation Instructions

Attachment Tabs:

Due to the design of the removable tabs, the RangeFinderII and Ambassador tow bars can not be used. Adapters, except the BX8833 and BX88151, can not be used with this baseplate.

Installation Notes: The grille, front fascia and blinker assemblies are removed and replaced during installation. Drilling is required. The air dam must be trimmed.

The dimensional variations between otherwise identical vehicles can be considerable. While the baseplate was designed for easy installation, it may be necessary to tailor the baseplate slightly to compensate for auto manufacturer's tolerances. These minor adjustments may include filing a hole slightly, bending electrical rods, and/ or bending end plates.

The BX8869 Bulb and Socket Wiring Kit is recommended for this vehicle.

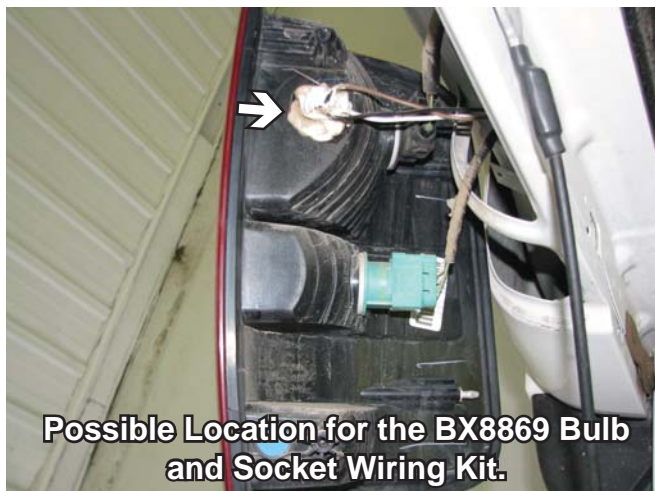

Installation Instructions:



1. Remove three push pins from underneath the front of the fascia. Do this to both sides of the vehicle. Set the pins aside to reinstall later.



2. Using a 21MM socket, remove two bolts on each side from underneath the plastic. Do this on both sides of the vehicle. Set bolts aside to be reinstalled later.

BX2612
2008 Ford F-150 FX2 Sport (2WD)
Installation Instructions



3. Inside the hood, using a 10MM socket remove one bolt on each side. Set bolts aside to be reinstalled later.



4. Using the 8MM socket, remove three bolts just behind the fascia across the front. Remove the fascia and set aside.

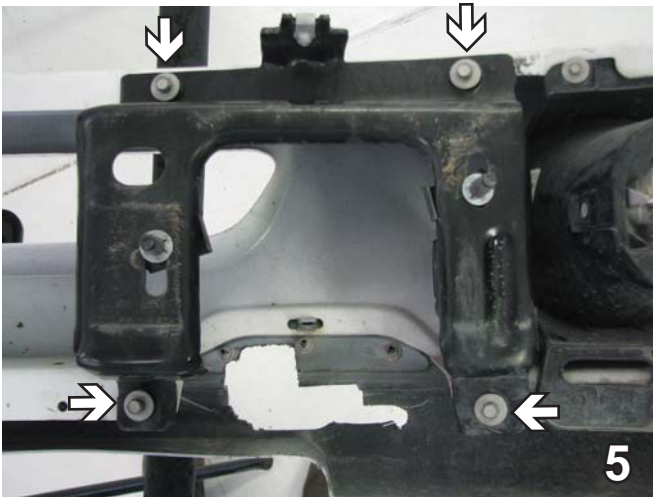

5. On the back side of the fascia, using a 10MM socket, remove the four bolts from the bracket. Do this to both sides. Remount the bracket onto the vehicle for the baseplate to go inside on both sides. Leave the bracket loose until the bumper is back on and in its original position.



6. Slide the baseplate up, start the two bottom bolts into the existing holes. Use 1/2-13 x 1 3/4" hex bolts with loctite, 1/2" lock washers and 1/2-13 whiz nuts. Using the baseplate as a template, drill the remaining hole (gray arrow). Do this on both sides of the vehicle.

BE SURE TO USE LOCTITE® RED ON ALL BOLTS BEFORE TIGHTENING. TIGHTEN ALL BOLTS ACCORDING TO THE TORQUE CHART ON THE FRONT PAGE OF THESE INSTRUCTIONS OR ON PAGE 3 OF THE BASEPLATE TOWING GENERAL INSTRUCTIONS.

BX2612
2008 Ford F-150 FX2 Sport (2WD)
Installation Instructions



7. Insert 1/2-13 x 1 3/4" hex bolts, 1/2" lock washers and 1/2-13 hex nylon insert lock nuts. Be sure to use loctite. Do this on both sides of the vehicle.

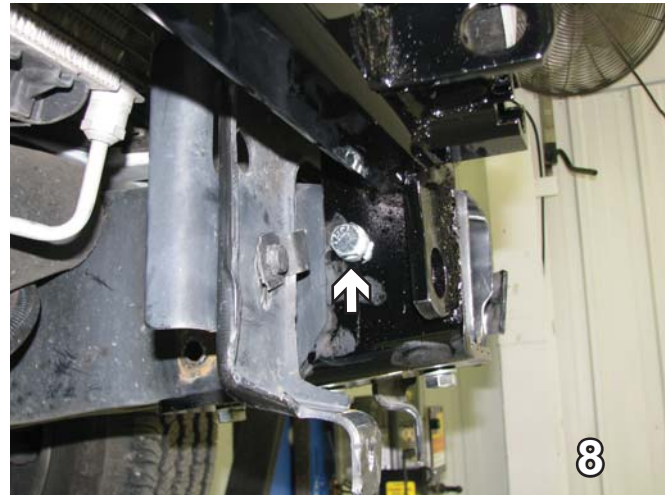

8. On the inside, using the baseplate as a template drill another hole. Attach 1/2-13 x 1 3/4" hex bolts, 1/2" lock washers and 1/2-13 hex nylon insert lock nuts. Be sure to use loctite. Do this on both sides of the vehicle.

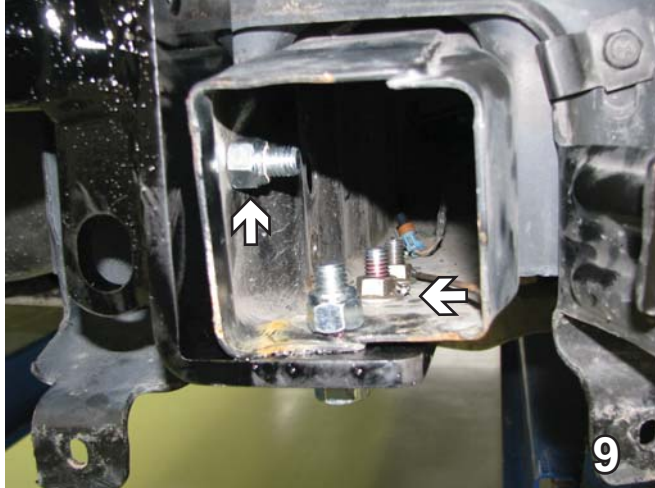

9. View of the frame end, showing all the bolts installed.



10. Attach the permanent baseplate safety cables to the provided convenience link on the baseplate (see gray arrow). The photo above shows the recommended installation of the permanent baseplate safety cables to frame of the vehicle (see white arrow). Additional options may interfere with suggested mounting, in this case secure the cables to a solid piece of the frame as described in the instructions included with the permanent baseplate safety cables. Be sure the safety cables do not rub against any hoses or moving parts.

BX2612
2008 Ford F-150 FX2 Sport (2WD)
Installation Instructions

Be sure that **ALL** electrical connections are plugged in properly and functioning **BEFORE** installing the fascia.

11. Replace the fascia, reinstalling all the nuts, pins and screws.

Install the tow bar and safety cables according to the instructions provided in their packages. When demonstrating this to the customer, be sure to include all the contents and packages.

Do **NOT** substitute other devices if the tow bar pins and clips are misplaced.



DEALER or INSTALLER:
Be certain the user receives the instruction sheets for their products.

CUSTOMER SERVICE COMMITMENT

Blue Ox is committed to providing you with exceptional customer care throughout your lifetime with our products. Our team is here to assist you with any questions you may have regarding the performance of your product. Simply call 1-800-228-9289 and you can speak with our customer care team.

Additionally, please visit our website to see which rallies our Destination America team will be attending. For a nominal fee, our service technician will service your towing system to ensure it's in proper working condition. Also as a commitment to our customers, should you visit our factory you can stay at our full service Blue Ox campground at no charge along with enjoying a factory tour.

Again thank you for being our customer and for the confidence you have shown in the performance of our products. It is because of customers like you we enjoy the success we have today.



© 2009 Blue Ox
One Mill Road, Industrial Park
Pender, Nebraska 68047
Phone: (402) 385-3051 • Fax: (402) 385-3360
www.blueox.us