



Baseplate Installation Instructions

BX2624
2010 Ford F350

Commercial Application Only Installation Instructions

Serial Number

Please read BOTH these Installation Instructions and the General Towing Instructions before attempting to install or operate this equipment.

1. Blue Ox® towing products and accessories are intended to be installed by Blue Ox® Dealers who are familiar with our products and have the equipment and knowledge to do “fit work.” When necessary, Blue Ox® Dealers can be found at www.blueox.com or by contacting our Customer Care Department at (402) 385-3051.

Attachment Tab Height: 22 1/4”

Attachment Tab Width: 31 7/8”

2. Many Blue Ox® Baseplates are designed to use existing holes and hardware to mount the baseplate to the towed vehicle. Even though bolts are there, do not assume they are adequate for baseplate mounting. Always use hardware supplied in the hardware kit or existing hardware specified in the Baseplate Towing Installation Instructions.

Bolt Torque Specifications

Torque in Foot-Pounds for Metric Bolts

Bolt Size	Grade 8.8	Grade 10.9
6MM	6	8
8MM	16	22
10MM	31	40
12MM	54	70
14MM	89	117

Confirm the towability and pre-towing procedures for your vehicle with the owner’s manual or contact the vehicle’s manufacturer for specific towing procedures.

Bolt Torque Specifications

Torque in Foot-Pounds for Inch Bolts

Bolt Size	Grade 5	Grade 8
1/4”	10	14
5/16”	19	29
3/8”	33	47
7/16”	54	78
1/2”	78	119
5/8”	154	230



If the front of your vehicle looks different than this, call us at (402) 385-3051.

WARNING

Failure to read and follow these instructions could result in separation of the towed vehicle from the tow bar, causing property damage, loss of towed vehicle, personal injury or death.

BX2624

2010 Ford F350 Commercial Application Only

Installation Instructions

Parts List

Ref. No.	Qty.	Part #	Description
1	1	61-6789	WELDMNT, BP, DS, BX2624
2	1	61-6790	WELDMNT, BP, PS, BX2624
3	1	101-6739	BRACKET, ELECTRICAL, BX2908
4	6	201-0369	1/2-13 X 3 1/2 HEX BOLT,GRD.5, ZP
5	6	203-0012	1/2 LOCK WASHER, ZP
6	12	203-0005	1/2 FLAT WASHER, ZP
7	6	202-0094	1/2-13 HEX NYL. INS. LOCK NUT, ZP
8	8	201-0351	5/8-11 X 2 HEX BOLT, GRD 5, ZP.
9	8	203-0006	5/8 FLAT WASHER, ZP
10	8	203-0013	5/8 LOCK WASHER, ZP
11	8	202-0064	5/8-11 HEX NYL. INS. LOCK NUT, ZP
12	4	201-0050	1/4-20 X 3/4 HEX BOLT GRD.5, ZP
13	2	203-0008	1/4 LOCK WASHER, ZP
14	4	203-0001	1/4 FLAT WASHER, ZP
15	4	202-0069	1/4-20 HEX FLANGE WHIZ LOCK NUT, ZP
	2	226-0049	BASEPLATE SAFETY CABLE, 36" CL IV
	2	229-0512	QUICKLINK, 1/2, ZP

Tools Required

8MM Socket	15/16" Socket/Wrench	Tape Measure
15MM Socket	Large Vise Grip	21/32" Drill Bit
18MM Socket	Drill	17/32" Drill Bit
3/4" Socket/Wrench	Torque Wrench	Loctite® RED

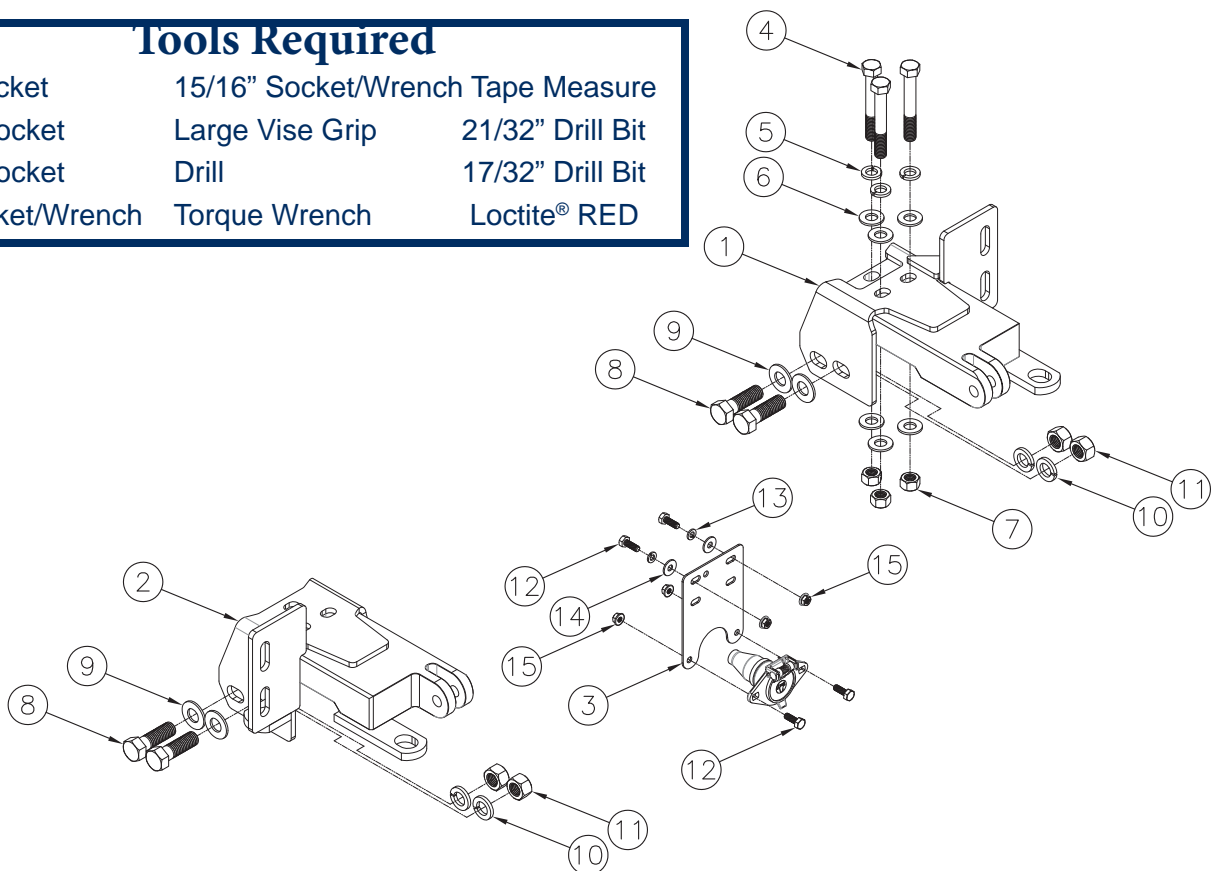

Important:

Use only genuine factory replacement parts on your baseplate. Do **NOT** substitute homemade or non-typical parts. If a bolt is lost or in need of replacement, for your safety and the preservation of your baseplate, be sure to use a replacement bolt of the same grade (In most cases it will be Grade 5, please reference the parts list above). Replacement parts may be ordered through your nearest Blue Ox® Dealer or Distributor. Failing to follow and/or altering these installation instructions in either installation or required equipment will void the manufacturer's warranty. Towing behind a non-motorized vehicle will void the warranty.

BX2624
2010 Ford F350
Commercial Application Only
Installation Instructions

Vehicle Weight:

Due to the weight of this vehicle, use of the BX7520P towbar is required. This baseplate will not work with standard Blue Ox towbar lugs or adapters due to the design of the attachment tabs. Also, you must insure your hitch rating is adequate for towing this vehicle.

Installation Notes: The fascia is removed for installation. Some drilling is required. Tow hooks must be removed and remain off the vehicle after installation.

The dimensional variations between otherwise identical vehicles can be considerable. While the baseplate was designed for easy installation, it may be necessary to tailor the baseplate slightly to compensate for auto manufacturer's tolerances. These minor adjustments may include filing a hole slightly, bending electrical rods or bending end plates.

The BX8869 Bulb & Socket Wiring Kit is recommended for this vehicle.



Installation Instructions:



1. Using a 13MM socket, remove two metric bolts located just forward of the front tire. Do this to both sides of the vehicle. Set bolts aside to be reinstalled later.



2. Remove three push pins from the bottom edge of the plastic cover. Set cover and push pins aside to be reinstalled later.

Handling of some cosmetic parts when installing this product may require the use of protective covers, rags, specialty tools, etc. to prevent damage.

BX2624
2010 Ford F350
Commercial Application Only
Installation Instructions

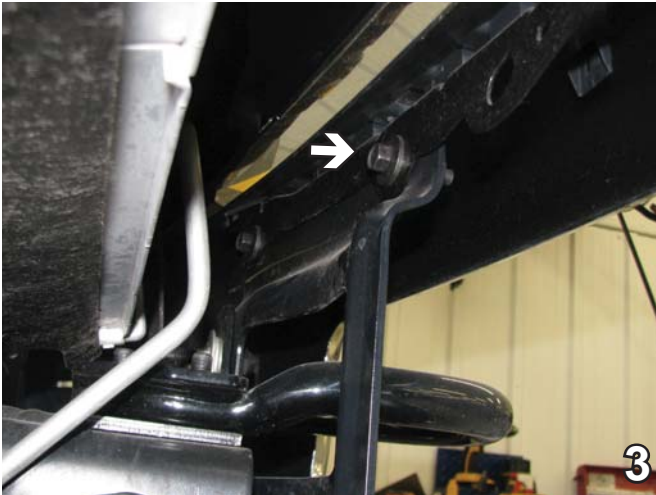

3. Remove the bolt which is exposed after removal of the cover. Set the bolt aside to be reinstalled later.



4. Remove the two bolts from the side of the tow hook cover. Do this on both sides of the vehicle. Set the bolts aside to be reinstalled later. Some vehicles may need to have the fog lights removed. If so use an 8MM socket to remove the three metric bolts on both sides.

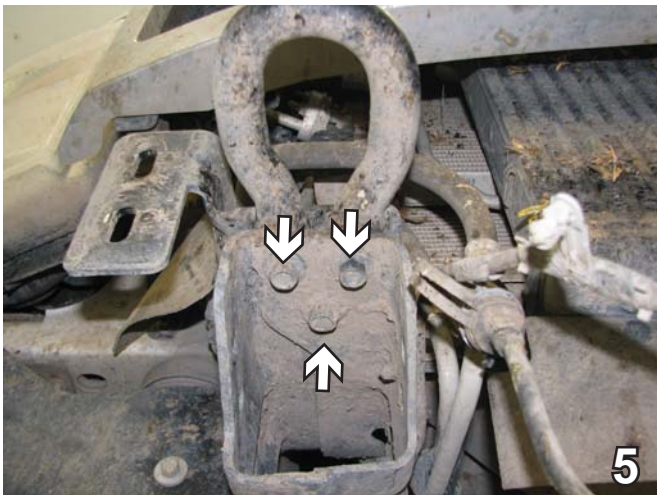

5. Remove the three 15mm bolts on the underside of the tow hook. Set tow hooks and bolts aside, they will not be reused. Use a 17/32" drill bit to ream the two front holes. Do this to both sides.

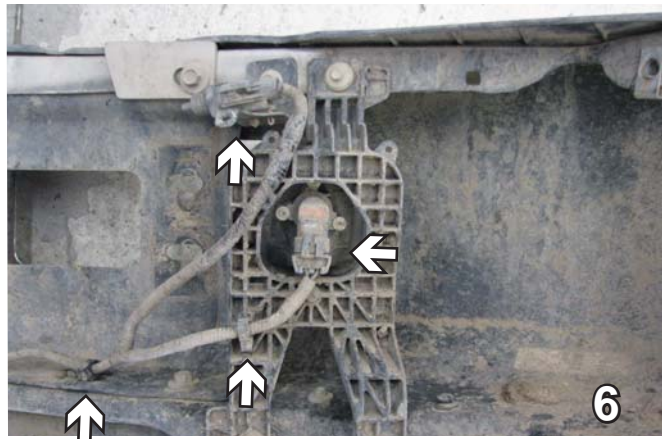

6. Some vehicles may contain a temperature sensor on the passenger side behind the bumper. On these models release the Christmas tree pin and release the extension pin from the end of the frame rail.



7. Remove the push pin from the back bottom lower radiator on the passenger side. Set the pin and the air dam aside to be reinstalled later.

BX2624
2010 Ford F350
Commercial Application Only
Installation Instructions

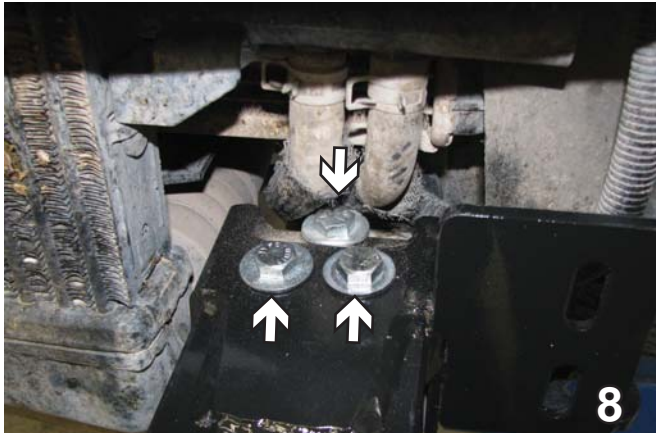

8. Slide the baseplate over the frame rail. Align with the top holes. Insert 1/2-13 x 3 1/2" hex bolts with 1/2" flat washer on the top. Attached to 1/2" lock washers and 1/2-13 hex nuts. Do this on both sides. Tighten with Loctite Red.

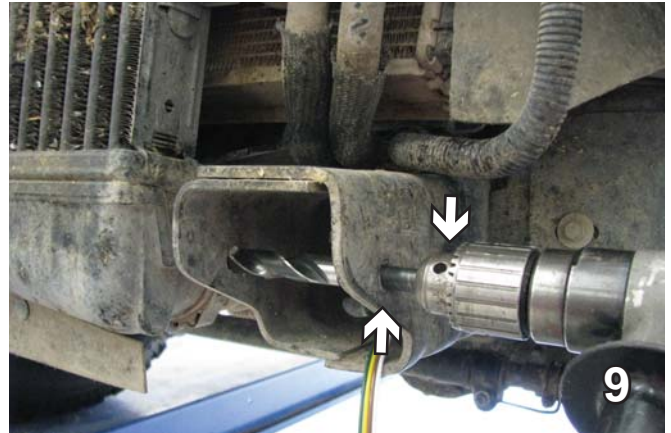

9. Align the baseplate with the existing holes in the frame. With the baseplate as a template, use a 17/32" drill bit to ream out the holes on both sides of the frame rail if needed. Do this on both sides of the vehicle.

BE SURE TO USE LOCTITE® RED ON ALL BOLTS BEFORE TIGHTENING. TIGHTEN ALL BOLTS ACCORDING TO THE TORQUE CHART ON THE FRONT PAGE OF THESE INSTRUCTIONS OR ON PAGE 3 OF THE BASEPLATE TOWING GENERAL INSTRUCTIONS.

When using power drills be aware of the dangers of torque and drill bit length.

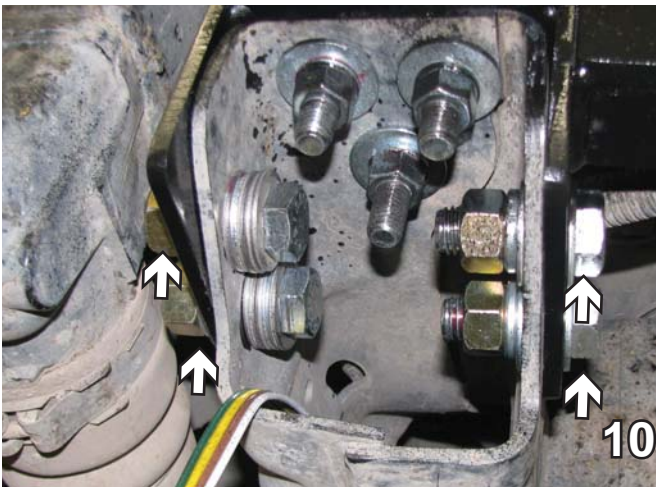

10. Loosely install all four 5/8-11 x 2" bolts with 5/8 flat washers attached to 5/8" lock washers and 5/8-11 hex nuts on the inside. Then use Loctite Red and tighten. Do this on both sides.

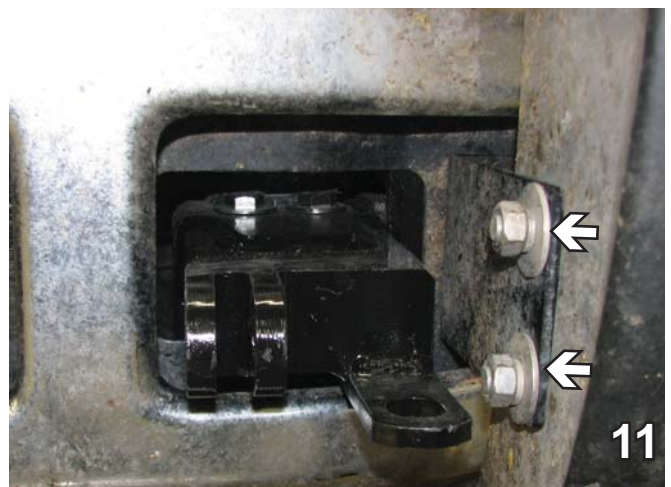

11. Reinstall the bolts attaching the tow hook covers. Do this on both sides.

BX2624
2010 Ford F350
Commercial Application Only
Installation Instructions



12. Attach the permanent baseplate safety cables to the provided convenience link on the baseplate. The photo above shows the recommended installation of the cables to frame of vehicle (see white arrow). Additional options may interfere with suggested mounting; in this case secure the cables to a solid piece of the frame as described in the instructions included with the permanent baseplate safety cables. Be sure the safety cables do not rub against any hoses or moving parts. Do this to both sides of the vehicle.

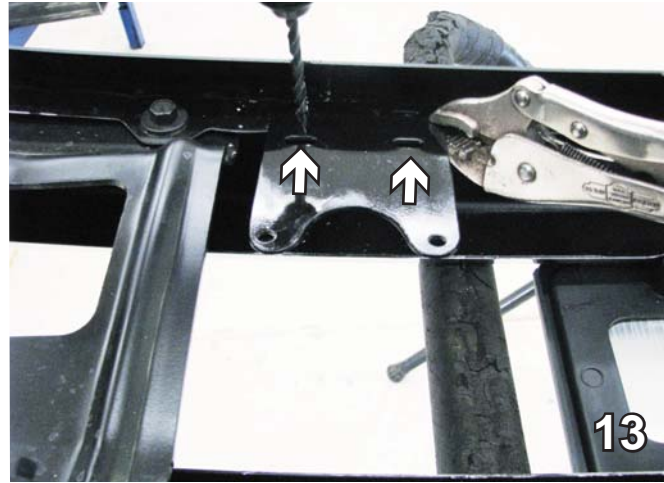

13. Place the metal bumper face down. Position the electrical bracket over the two existing holes on the inside top driver's side. Drill out the hole on the left using a 5/16" drill bit.



14. Install 1/4-20 x 3/4" bolts with 1/4" flat washers, 1/4 lock washers and 1/4-20 whiz nuts.



15. Install the electrical plug on the front of the fascia.

Be sure that **ALL** electrical connections are plugged in properly and functioning **BEFORE** installing the fascia.

16. Reinstall bumper, bolts and reconnect wiring. The installation of the baseplate is complete.

BX2624
2010 Ford F350
Commercial Application Only
Installation Instructions

DEALER or INSTALLER:
Be certain the user receives the
instruction sheets for their products.

Install the tow bar and safety cables according to the instructions provided in their packages. When demonstrating this to the customer, be sure to give all the contents and packages to the consumer.

Do **NOT** substitute other devices if the tow bar pins and clips are misplaced.



With standard attachment tabs.

If the baseplate is in an accident, it must be replaced. **DO NOT** use it again! An accident can cause unseen damage and using it again could result in more damage or serious injury. **DO NOT** use the baseplate if it is damaged or missing parts.

CUSTOMER SERVICE COMMITMENT

Blue Ox is committed to providing you with exceptional customer care throughout your lifetime with our products. Our team is here to assist you with any questions you may have regarding the performance of your product. Simply call (402) 385-3051 and you can speak with our customer care team.

Additionally, please visit our website to see which rallies our Destination America team will be attending. For a nominal fee, our service technician will service your towing system to ensure it's in proper working condition. Also as a commitment to our customers, should you visit our factory you can stay at our full service Blue Ox campground at no charge along with enjoying a factory tour.

Again thank you for being our customer and for the confidence you have shown in the performance of our products. It is because of customers like you we enjoy the success we have today.



© 2010 Blue Ox
One Mill Road, Industrial Park
Pender, Nebraska 68047
Phone: (402) 385-3051 • Fax: (402) 385-3360
www.blueox.com