



BX2625

2011-15 Lincoln MKX (includes Adaptive Cruise Control) Installation Instructions

Serial Number

Attachment Tab Height: 18-1/4"

Attachment Tab Width: 22"

Please read BOTH these Installation Instructions and the General Instructions prior to installing or operating this equipment.

- Blue Ox® towing products and accessories are intended to be installed by Blue Ox® Dealers who are familiar with our products and have the equipment and knowledge necessary to do "fit work". If needed, Blue Ox® Dealers can be found at www.blueox.com or by contacting our Customer Care Department at (402) 385-3051.
- Many Blue Ox® baseplates are designed to use existing holes and hardware to mount the baseplate to the towed vehicle. Even though bolts are there, do not assume they are adequate for baseplate mounting. Always use the hardware supplied in the hardware kit and existing hardware as specified in the installation instructions.

Bolt Torque Specifications
Torque in Foot-Pounds for Metric Bolts

Bolt Size	Grade 8.8	Grade 10.9
6MM	6	8
8MM	16	22
10MM	31	40
12MM	54	70
14MM	89	117

Bolt Torque Specifications
Torque in Foot-Pounds for Inch Bolts

Bolt Size	Grade 5	Grade 8
1/4"	10	14
5/16"	19	29
3/8"	33	47
7/16"	54	78
1/2"	78	119
5/8"	154	230



If the front of your vehicle looks different than this, please contact us at (402)385-3051.

Reference your vehicle owner's manual for manufacturer's towing specifications.

! WARNING

Failure to read and follow these instructions could result in separation of the towed vehicle from the tow bar, causing property damage, loss of towed vehicle, personal injury or death.

BX2625
2011-15 Lincoln MKX (includes Adaptive Cruise Control)
Installation Instructions

Instruction Notes: The fascia, ACC Box, coolant lines and windshield washer fluid reservoir are removed and reinstalled for the baseplate installation. The metal bumper is removed and is not reinstalled. Some drilling and trimming is required.

Place all components that are removed on a flat, sturdy surface. All items will be reinstalled unless otherwise noted after the baseplate is installed.

The dimensional variations between otherwise identical vehicles can be considerable. While the baseplate was designed for easy installation, it may be necessary to tailor the baseplate slightly to compensate for vehicle manufacturer's tolerances.

NOTICE

- Handling of some cosmetic parts when installing this product may require the use of protective covers, rags, specialty tools, etc. to prevent damage.
- When using power drills be aware of the dangers of torque and drill bit length.
- When using a reciprocating saw be aware of objects behind the cutting surface.
- Use a good quality paint to spray cut edges of frame to prevent rusting.
- Be sure that **ALL** electrical connections are plugged in and accessories are functioning properly before reinstalling the fascia.
- Do not use the towed vehicle for storing luggage, equipment, etc. This may cause you to exceed the towing capacity of the tow bar, baseplate and its accessories.
- Be sure to use Loctite® Red on all bolts before tightening. Tighten all bolts according to the torque chart provided.
- Dealer or installer be certain the user receives these instruction sheet.
- If the baseplate is in an accident, it must be replaced. **DO NOT** use it again! An accident can cause unseen damage and using it again could result in more damage or serious injury. **DO NOT** use the baseplate if it is damaged or missing parts.

BX2625

2011-15 Lincoln MKX (includes Adaptive Cruise Control)

Installation Instructions

Tools Required

Large Vise Grip
 Flat Screwdriver
 Utility Knife
 Phillips Screwdriver
 Torque Wrench
 Drill
 Reciprocating Saw
 Tape Measure
 Loctite® RED
 1-1/4" Holesaw
 1/4" Drill Bit
 13/32" Drill Bit
 17/32" Bit
 5.5MM Socket
 8MM Socket
 10MM Socket
 13MM Socket
 9/16" Socket
 9/16" Wrench
 3/4" Wrench
 3/4" Socket

THESE BOLTS & NUTS
TO BE USED IF EQUIPPED
WITH COOLANT LINES
DESCRIBED IN THE INSTRUCTIONS

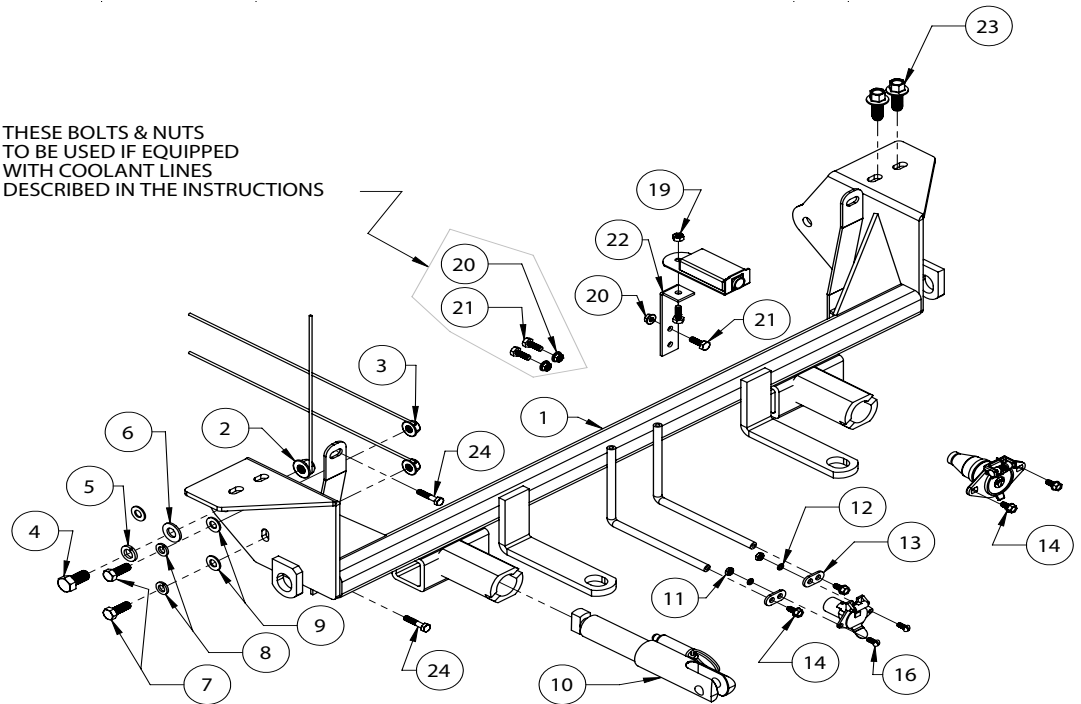

Item No.	Part No.	Description	C
1	61-6800	BX2625 Baseplate	1
2	61-4029	1/2"-13 Whiz Nut w/ 10" Wire	2
3	61-4978	3/8"-16 Whiz Nut w/ 14" Wire	4
4	201-0060	1/2"-13 x 1" Hex Head Bolt, Grade 5, ZP	2
5	203-0012	1/2" Lock Washer, ZP	2
6	203-0005	1/2" Flat Washer, ZP	2
7	201-0443	3/8"-16 x 1" Hex Head Bolt, Grade 5, ZP	4
8	203-0010	3/8" Lock Washer, ZP	4
9	203-0003	3/8" Flat Washer, ZP	4
10	62-3469	Attachment Tab	2
11	202-0047	#10-32 Hex Nut	2
12	203-0054	#10 Lock Washer	2
13	101-5822	4-Way Connector Adapter	2
14	201-0553	1/4"-20 x 1/2" Hex Type F TCS, ZP	2
15	226-0049(not shown)	36" Class IV Safety Cable	2
16	201-0192	#10-32 x 1/2" Round Head Screw	2
17	229-0512(not shown)	1/2" Quick Link, ZP	4
18	290-0437(not shown)	Black Cap Plug Receiver	2
19	202-0102	1/4"-20 Hex Nylon Nut, ZP	1
20	202-0069	1/4"-20 Hex Whiz Lock Nut	3
21	201-0050	1/4"-20 x 3/4" Hex Head Bolt, Grade 5, ZP	4
22	102-7186	Breakaway Bracket	1
23	Existing	Top Bumper Bolt	4
24	Existing	Face Bumper Bolt	4

Important:

Use only genuine factory replacement parts on your baseplate. Do **NOT** substitute homemade or non-typical parts. If a bolt is lost or in need of replacement, for your safety and the preservation of your baseplate, be sure to use a replacement bolt of the same grade (In most cases it will be Grade 5, please reference the parts list above). Replacement parts may be ordered through your nearest Blue Ox® Dealer or Distributor. Failing to follow and/or altering these installation instructions in either installation or required equipment will void the manufacturer's warranty. Towing behind a non-motorized vehicle will void the warranty.

BX2625
2011-15 Lincoln MKX (includes Adaptive Cruise Control)
Installation Instructions

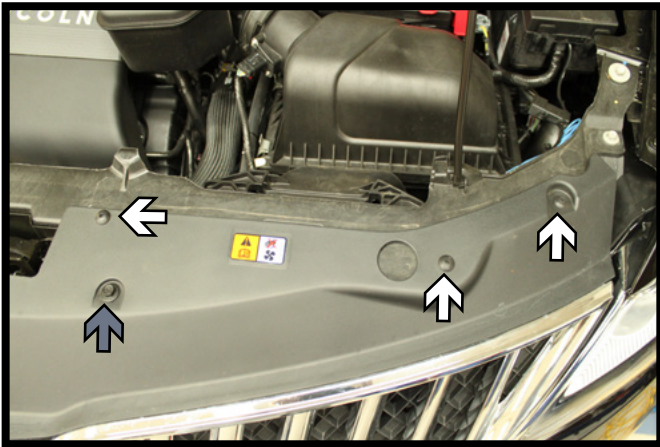

1. Remove the three (3) push pins (white) and then, using a 10MM socket, remove the one (1) screw (gray) from the plastic radiator cover. Do this to both sides of the vehicle.



2. Using a 5.5MM socket, remove the three (3) screws just forward of the front tire in the wheel well. Do this to both sides of the vehicle.

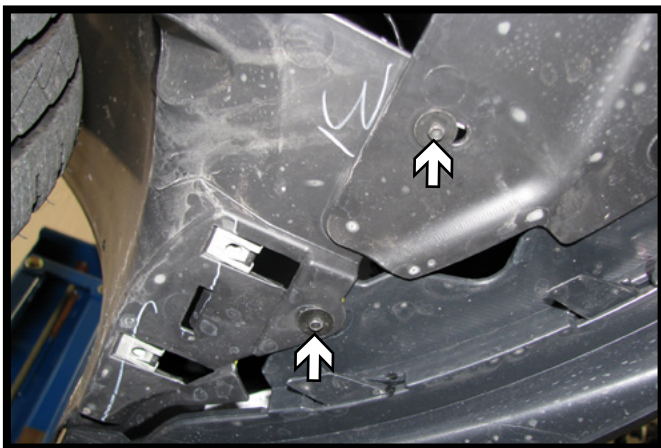

3. Using a 5.5MM socket, remove the two (2) screws from underneath the front edge of fascia. Do this to both sides of the vehicle.

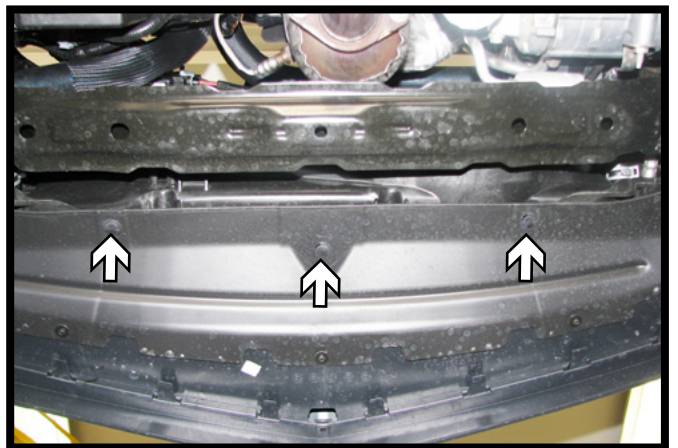

4. Remove the three (3) push pins that are located in the center of vehicle on the underside of the fascia. Then on the corners of the fascia pull out to the side and forward to remove. Set fascia aside.

BX2625
2011-15 Lincoln MKX (includes Adaptive Cruise Control)
Installation Instructions

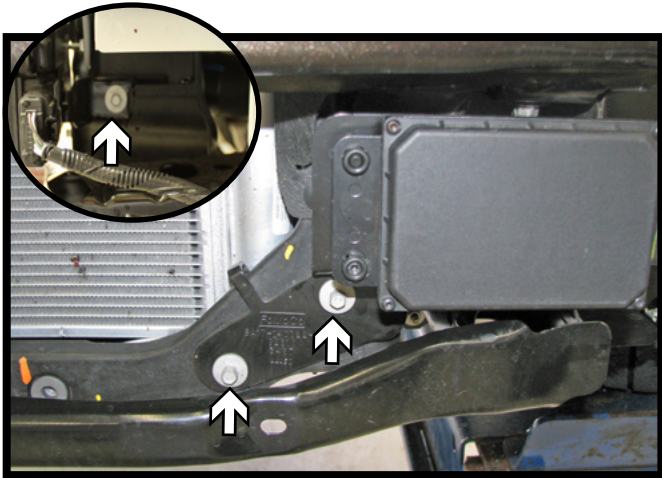

5. If vehicle is equipped with ACC, on the drivers side only, using an 8mm socket remove the two (2) bolts from the front and the one (1) on the back side of the cruise control box.

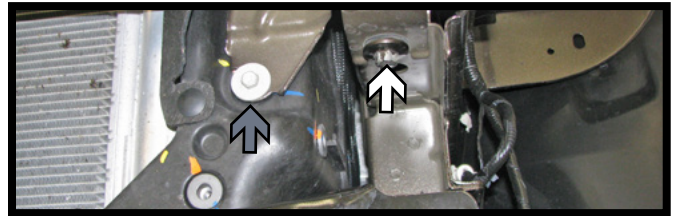
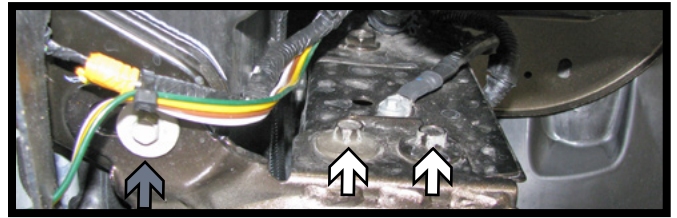

6. Using a 13MM socket, remove the two (2) bolts from the top of the metal bumper and one (1) bolt from the bottom (white). Then using a 10MM socket, remove the one (1) bolt from the top and bottom of the bumper (gray). Do this to both sides of the vehicle. Remove the metal bumper from the vehicle.

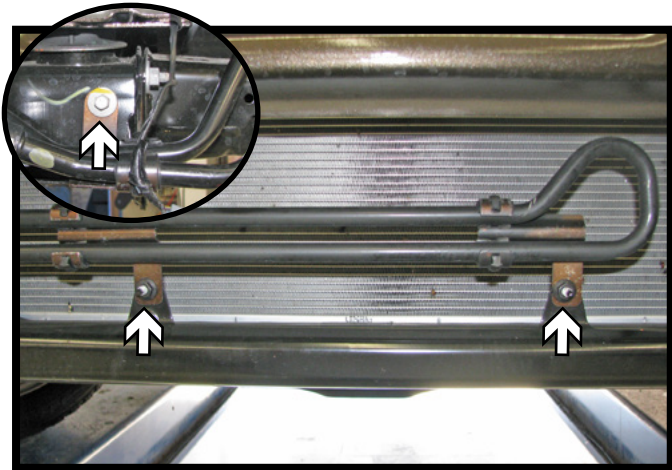

7. On the passenger side front of the vehicle, using a 10MM socket remove the two (2) bolts (white) from the lower coolant line. Then using a 8MM socket, remove the one (1) bolt (gray) located on the side of the vehicle. The lower coolant line now can be swung out of the way.

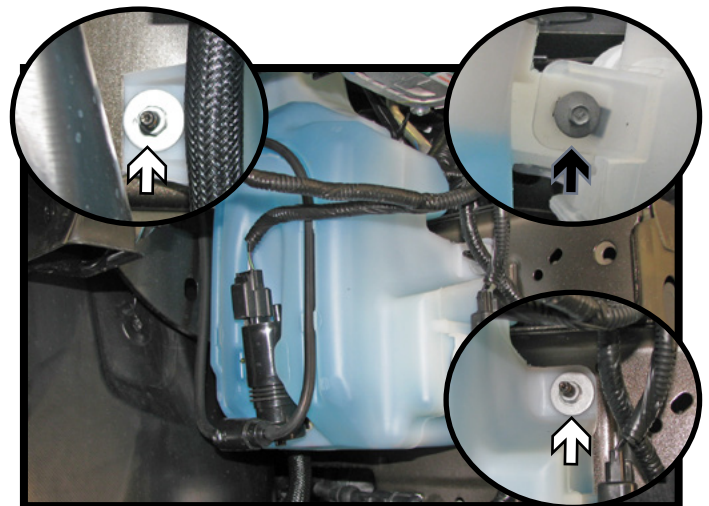

8. On the passengers side, using an 8MM socket remove the bolt on the top (black). With the 10MM socket remove the two (2) nuts on either side (white). Unplug the hoses and electrical lines and remove the washer fluid reservoir.

BX2625
2011-15 Lincoln MKX (includes Adaptive Cruise Control)
Installation Instructions

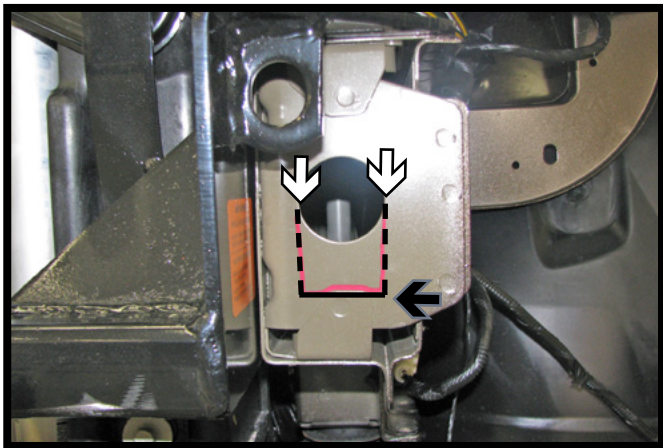

9. Using a reciprocating saw, make the two (2) vertical cuts (white) to approximately the bend line (black). Bend the cut area into the frame end and as far down as possible. Do this to both sides of the vehicle.



10. Using a reciprocating saw, cut off the tabs that the lower coolant line were attached to, being careful not to cut into the radiator.

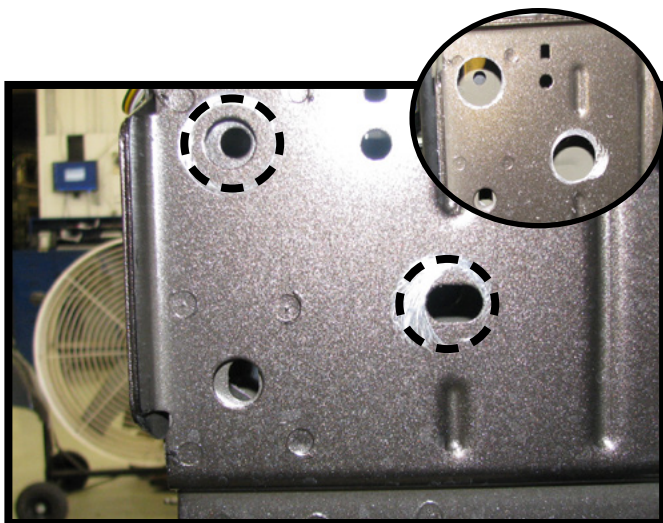

11. Using a 1 1/4" hole saw, drill two (2) 1-1/4" holes into the frame, utilizing the two (2) existing holes in the side of the frame. This gives an access hole to tighten fasteners. Do this to both sides of the vehicle.

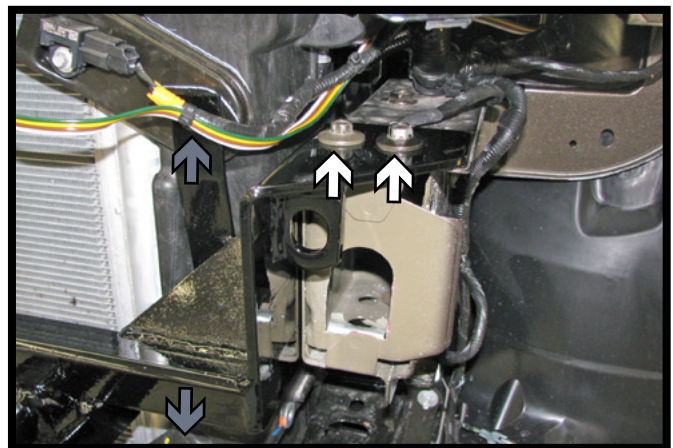

12. Place baseplate on top of frame and line up the holes in the baseplate with the two (2) existing holes on top of the frame. Reinstall the four (4) existing bolts from step 6, two (2) on the top (white) and (2) on the face (gray). Do this to both sides of the vehicle.

BX2625
2011-15 Lincoln MKX (includes Adaptive Cruise Control)
Installation Instructions

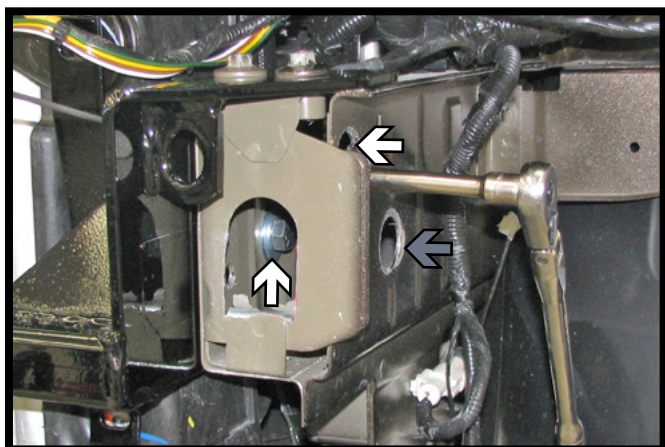

13. Align lower base plate holes to the existing holes. They may need to be reamed out using a 13/32" or 17/32" drill bit. Install a 3/8"-16 x 1" bolt, 3/8" lock washer, 3/8" flat washer and a 3/8" nut w/ wire into the front holes and tighten down (white). Then install a 1/2"-13 x 1" bolt, 1/2" lock washer, 1/2" flat washer and a 1/2" nut plate into rear hole (gray). Do this to both sides of the vehicle.

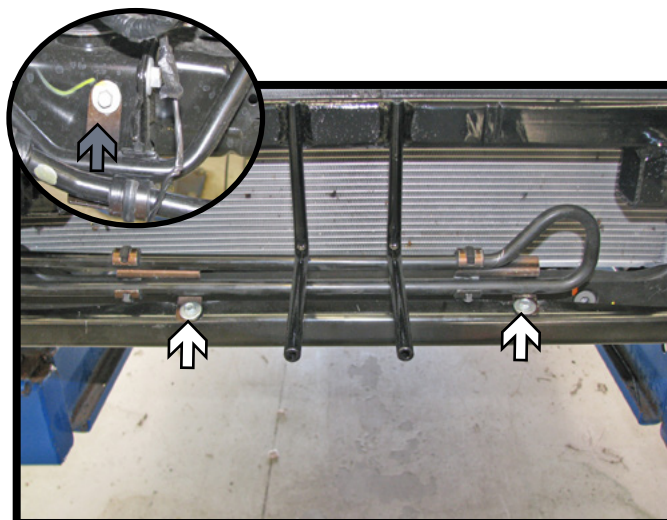

15. Remove coolant line brackets from the back side and relocate to the front of the coolant line. Using the bracket as a template, drill 1/4" holes into the lower cross member and install 1/4"-20 x 3/4" bolts and 1/4"-20 nuts on the back side of the cross member (white). Reinstall the bolt located on the side of the vehicle for the lower coolant line (gray).



16. Attach the permanent baseplate safety cables to the provided convenience link on the baseplate. The photo beside shows the recommended installation of the cables to frame of vehicle. Additional options may interfere with suggested mounting; in this case, secure the cables to a solid piece of the frame as described in the instructions included with the permanent baseplate safety cables. Be sure the safety cables do not rub against any hoses or moving parts. Do this on **BOTH** sides of the vehicle.

BX2625
2011-15 Lincoln MKX (includes Adaptive Cruise Control)
Installation Instructions

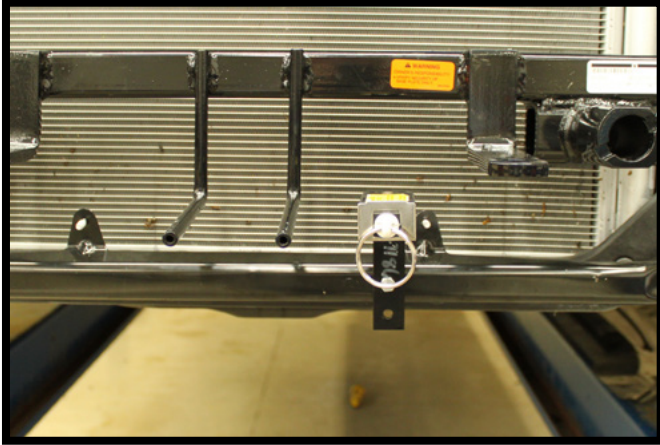

17. **OPTIONAL:** Install the breakaway bracket and breakaway on the driver's side of the vehicle between the convenience link and electrical rods. Drill a 1/4" hole into the frame located below the radiator. Attach the bracket to frame of vehicle with 1/4"-20 x 3/4" bolt and 1/4"-20 nylon nut. Attach the breakaway to the bracket with a 1/4"-20 x 3/4" bolt and 1/4"-20 locking nut.

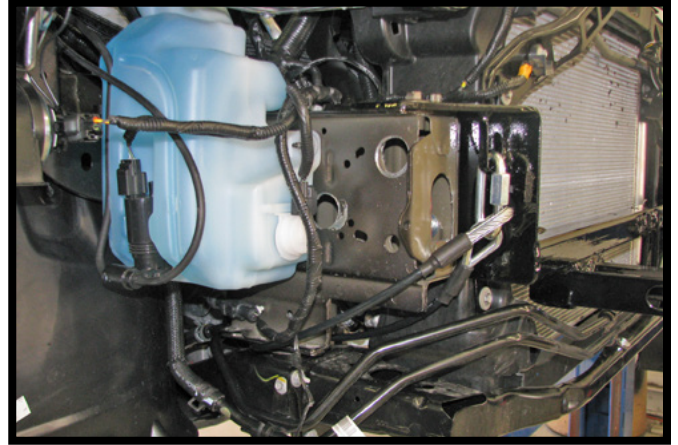

18. Reinstall the washer fluid reservoir, cruise control box. Hold the fascia as close to its original position. Mark and trim for the attachment tabs and convenience links. Reinstall the fascia.

CUSTOMER SERVICE COMMITMENT

Blue Ox® is committed to providing you with exceptional customer care throughout your lifetime with our products. Our team is here to assist you with any questions you may have regarding the performance of your product. Simply call (402) 385-3051 and you can speak with our customer care team.

Additionally, please visit our website to see which rallies our Destination America team will be attending. For a nominal fee, our service technician will service your towing system to ensure it's in proper working condition. Also, as a commitment to our customers, should you visit our factory, you can stay at our full service Blue Ox® campground at no charge along with enjoying a factory tour.

Again, thank you for being our customer and for the confidence you have shown in the performance of our products. It is because of customers like you we enjoy the success we have today.

© 2012 Blue Ox
One Mill Road, Industrial Park
Pender, Nebraska 68047
Phone: (402) 385-3051
Fax: (402) 385-3360
www.blueox.com