

Please read **BOTH** these Installation Instructions and the General Towing Instructions before attempting to install or operate this equipment.

- Blue Ox® towing products and accessories are intended to be installed by Blue Ox® Dealers who are familiar with our products and have the equipment and knowledge to do “fit work.” When necessary, Blue Ox® Dealers can be found at www.blueox.us or by contacting our 24/7 Customer Care Department at (888) 425-5382.
- Many Blue Ox® Baseplates are designed to use existing holes and hardware to mount the baseplate to the towed vehicle. Even though bolts are there, do not assume they are adequate for baseplate mounting. Always use hardware supplied in the hardware kit or existing hardware specified in the Baseplate Towing Installation Instructions.

Attachment Tab Height: 11 1/2”
Attachment Tab Width: 18”

Bolt Torque Specifications

Torque in Foot-Pounds per Metric Bolts

Bolt Size	Grade 8.8	Grade 10.9
6MM	6	8
8MM	16	22
10MM	31	40
12MM	54	70
14MM	89	117

Confirm the towability and pre-towing procedures for your vehicle with the owner’s manual or contact the vehicle’s manufacturer for specific towing procedures. You can also contact REMCO for additional information at 1(800)228-2481.

Bolt Torque Specifications

Torque in Foot-Pounds per Inch Bolts

Bolt Size	Grade 5	Grade 8
1/4”	10	14
5/16”	19	29
3/8”	33	47
7/16”	54	78
1/2”	78	119
5/8”	154	230



! WARNING

Failure to read and follow these instructions could result in separation of the towed vehicle from the tow bar, causing property damage, loss of towed vehicle, personal injury or death.

BX2712 2007 Kia Rondo Installation Instructions

Parts List

Ref. No.	Qty.	Part #	Description
1	1	61-6442	WLDM'T, BASEPLATE, BX2712
2	6	61-5208	WLDT, NUT PLT, 1/4X1X1, 3/8 BLT WIR
3	6	201-0368	3/8-16 X 1 1/4 HEX HEAD BOLT,GRD. 5
4	6	203-0010	3/8 LOCK WASHER, ZP
5	4	201-0004	5/16-18 X 1 1/4 HEX TAP BOLT GRD.5
6	9	203-0009	5/16 LOCK WASHER, ZP
7	4	202-0070	5/16-18 HEX FLANGE WHIZ LOCK NUT ZP
8	1	201-0702	6MM-1.00 X 45MM HEX BOLT, GRD 8.8,
9	3	201-0655	6MM-1.0 X 30MM HEX BOLT, GRD8.8,ZP
10	1	203-0002	5/16 FLAT WASHER, ZP
11	2	201-0553	1/4-20 X 1/2 HX.WSHD.TYPE F TCS, ZP
12	2	201-0192	10-32 X 1/2 SLOT, RD. HD. SCREW
13	2	203-0054	#10 LOCK WASHER
14	2	202-0047	#10-32 HEX NUT
15	2	101-5822	ADAPTER, 4 WAY CONNECTOR
16	2	62-3468	ATT TAB ASSY, REM, SF/SB, 1 HOLE
	2	290-0437	RECEIVER, CAP PLUG (BLK) (Not Shown)
	2	229-0359	QUICKLINK, 3/8, ZP (Not Shown)
	2	226-0046	BASEPLATE SAFETY CABLE, 36" CL III (Not Shown)

Tools Required

8MM Socket	11/32" Drill Bit
10MM Socket	13/32" Drill Bit
12MM Socket	Flat Screwdriver
9/16" Socket	Phillips Screwdriver
1/2" Socket	Large Vise Grips
Loctite® RED	Needle Nose Pliers
	Reciprocating Saw

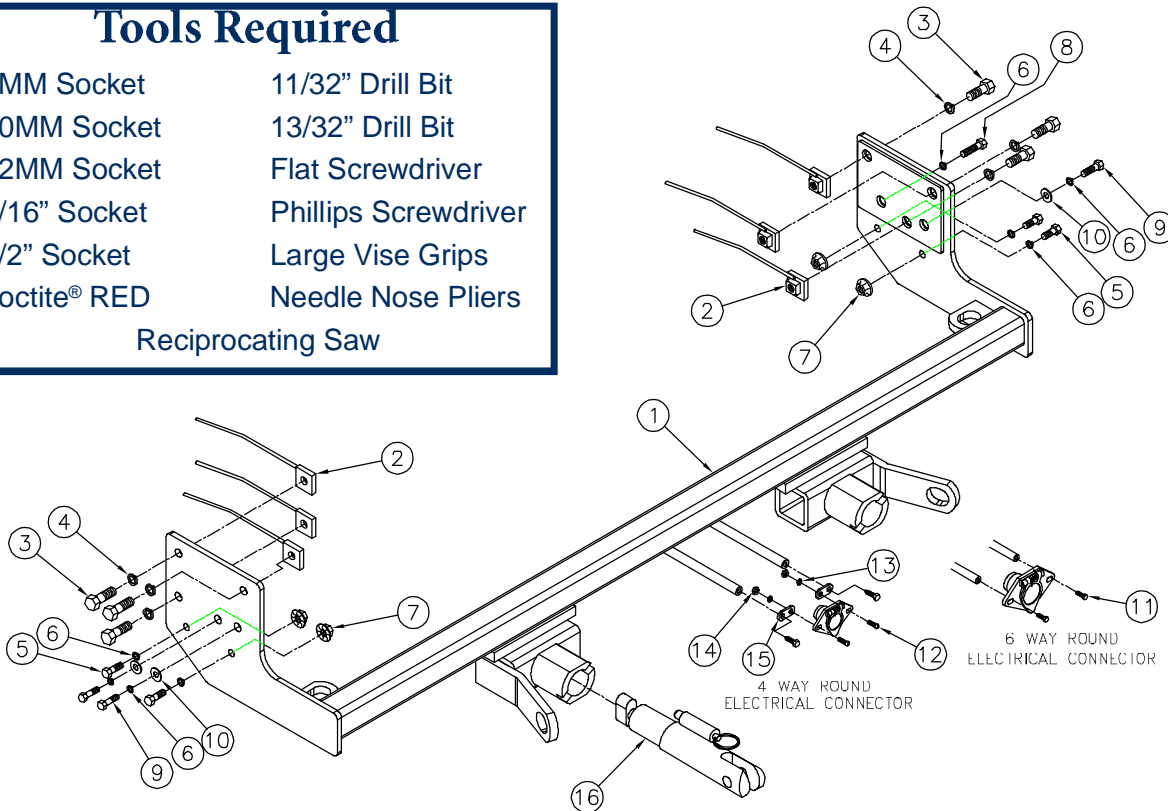

Important:

Use only genuine factory replacement parts on your baseplate. Do **NOT** substitute homemade or non-typical parts. If a bolt is lost or in need of replacement, for your safety and the preservation of your baseplate, be sure to use a replacement bolt of the same grade (In most cases it will be Grade 5, please reference the parts list above). Replacement parts may be ordered through your nearest Blue Ox® Dealer or Distributor.

BX2712 2007 Kia Rondo Installation Instructions

Vehicle Weight:

The weight of this vehicle is near the Class III, 5,000 lb. rating limitations. Some models, depending on options, may well exceed this 5,000 lb rating. Be sure to confirm the weight of your individual vehicle before towing. As of 1999 the Aventa® II is now 10,000 lbs. and either the Aventa® II or the Aventa® LX tow bar must be used for these applications.

Tow Bar Adapters are NOT to be used with vehicles weighing over 5,000 lbs.

Installation Notes: Trimming of the fascia is required.

The dimensional variations between otherwise identical vehicles can be considerable. While the baseplate was designed for easy installation, it may be necessary to tailor the baseplate slightly to compensate for auto manufacturer's tolerances. These minor adjustments may include filing a hole slightly, bending electrical rods and/ or bending end plates.

The BX8869 Bulb & Socket Wiring Kit is recommended for this vehicle.

Installation Instructions:



1. Using a flat screwdriver, remove three push pins from the top edge of the fascia. Do this to both sides of the vehicle. Set push pins aside to be reinstalled later.

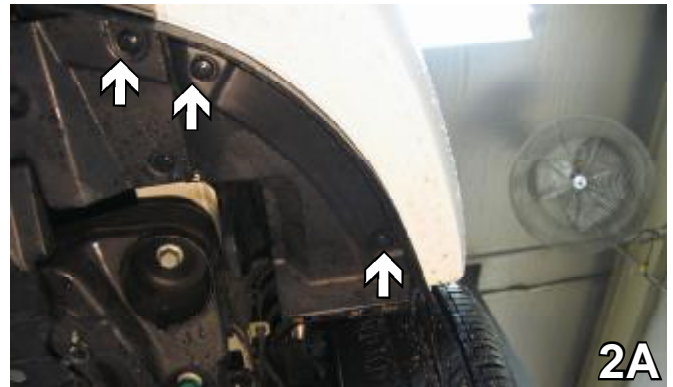

2. Using a flat screwdriver, remove thirteen push pins under the fascia. There are three in each corner and seven more across the middle. Set push pins aside to be reinstalled later.

BX2712 2007 Kia Rondo Installation Instructions



3. Using a 10MM socket, remove four metric bolts from under the fascia across the front. Set bolts aside to be reinstalled later.



4. Using an 8MM socket remove the bolt in fascia corner in front of the tire. Do this to both sides of the vehicle. Set the bolt aside.



5. Using a flat screwdriver, remove ten push pins on top of the fascia. The four on the left are also on the other side (grey arrows, Step 6). Set push pins aside to be reinstalled later.



6. Using a 10MM socket, remove the two bolts from the air breather. Set bolts aside to be reinstalled later. Remove black plastic radiator covering.

7. Using a 10MM socket, remove the two bolts by the headlight. Do this on both sides. Set bolts aside to be reinstalled later.



BX2712 2007 Kia Rondo Installation Instructions

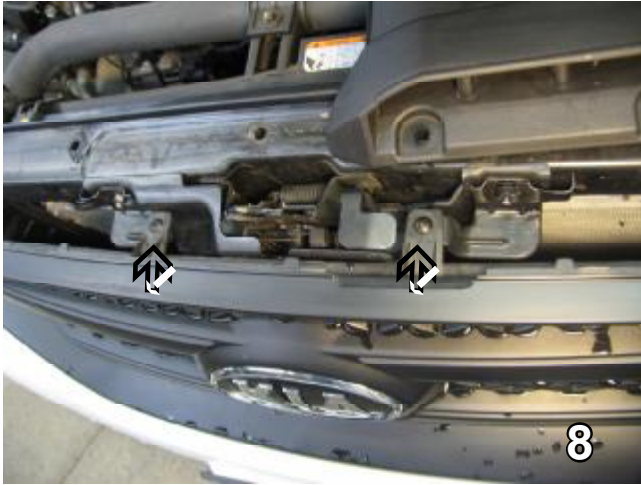

8. Using a Phillips screwdriver, remove the two screws from the top edge of the fascia. Pull fascia corners out to the side of the vehicle on both sides, then forward. Carefully set fascia and screws aside to be later reinstallation.

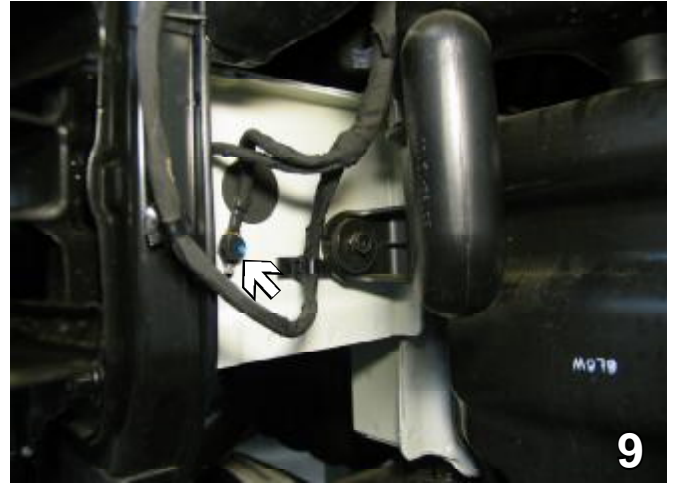

9. On the driver's side, relocate the ground wires. They will be reconnected later.

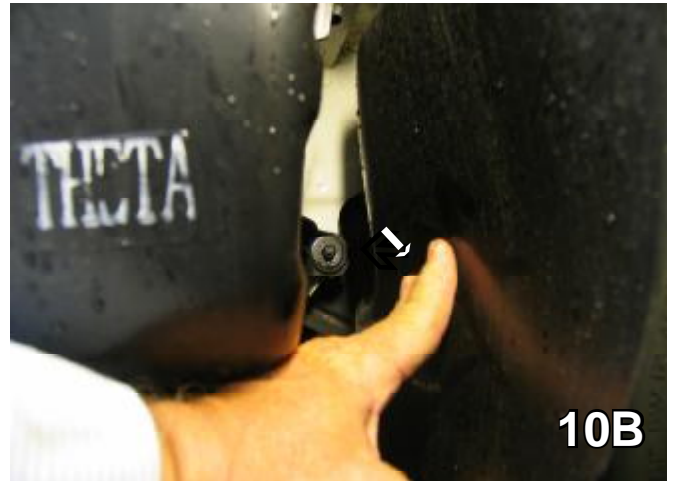

10. Remove the air baffle by using a 10MM socket to remove the bolt on top and one behind the wheel well cover in front of the tire. Set bolts and air baffle aside for later reinstallation.



11. Using a needle nose pliers squeeze the pin on top of the washer reservoir and pull it up. Disconnect all hoses and electrical wires.

BX2712 2007 Kia Rondo Installation Instructions

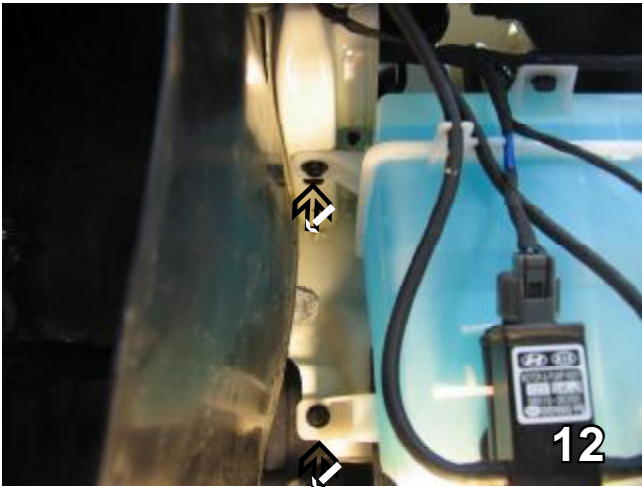

12. Using a 10MM socket, remove two metric bolts from the washer reservoir. Set bolts aside to be reinstalled later.

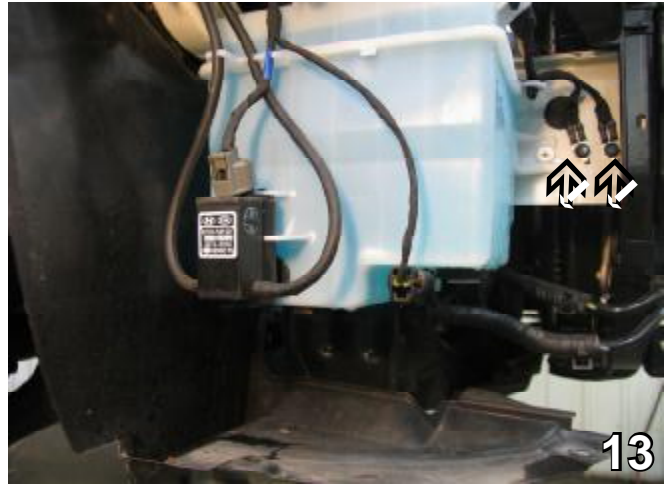

13. The washer reservoir will now slide back toward the tire to release the front pin. Then remove with a Phillips screwdriver. The wire connectors on the back will need to be removed with a 10MM socket. Set aside for later reinstallation.



14. Using a 12MM socket, remove the bumper bolt. Do this on both sides.



15A

15. On the passenger side, using a 10MM socket, remove the three bolts holding the transmission fluid line. Let the line swing down during installation of the baseplate. Set bolts aside for later reinstallation.



15B

BX2712 2007 Kia Rondo Installation Instructions



16. Using a 10MM socket, remove the bolt holding the bracket which was under the transmission line. It will be reinstalled after the transmission line is reinstalled.

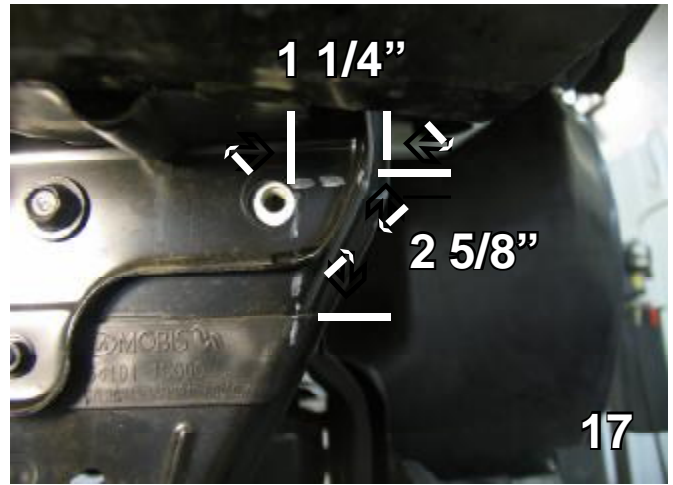

17. Using a reciprocating saw, cut straight across from the top of the hole 1 1/4" and down 2 5/8" through all three layers.

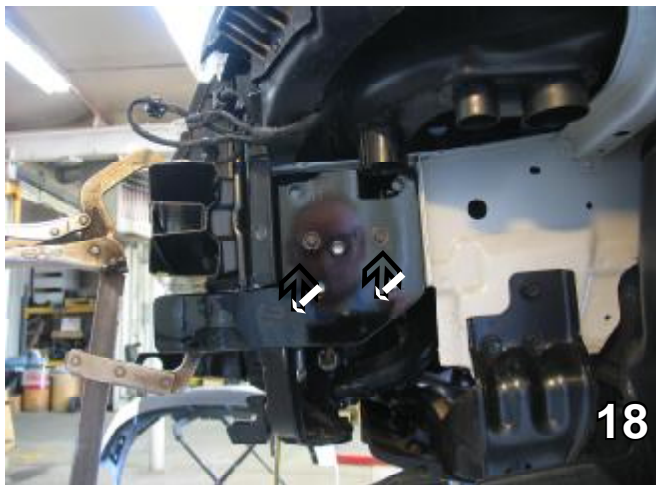

18. Slide the baseplate up to trimmed area. Start 6MM-1 x 30MM hex bolts in the existing holes. Clamp the baseplate to the bumper. Do this on both sides.

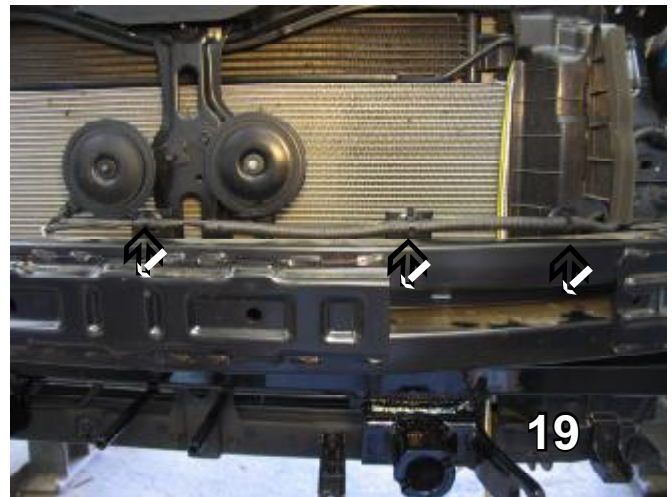

19. Remove the three plastic clips above the bumper with a flat screw driver.

20. Remove the three bolts holding the bumper, use a 10MM socket to remove the bolt in the middle (grey arrow) and a 12MM socket to remove the other two. Do this on both sides. Set bolts aside for later reinstallation.

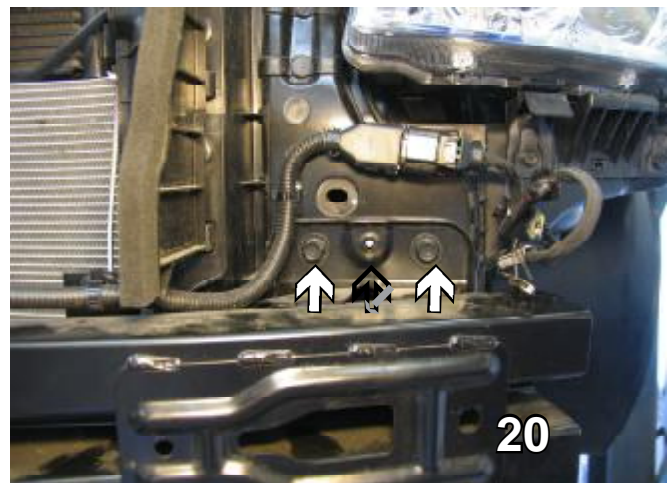

BX2712 2007 Kia Rondo Installation Instructions



21. Using a 12MM socket, remove the metric bolts from under the bumper. You should be able to do that with the baseplate on. Do this on both sides. Set bolts aside to be reinstalled later. Take the bumper off. This will make it possible to put the nut plates inside the hole which is now exposed.

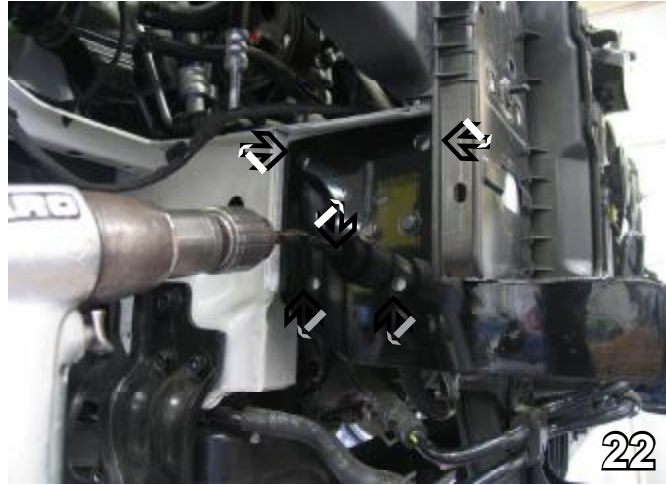

22. Use the baseplate as a template with a 13/32" drill bit, drill the three holes on passenger's side (white arrows). Drill the remaining two holes with a 11/32" drill bit (grey arrows). Do to both sides.



23. Use 5/16-18 x 1 1/4" hex bolts with 5/16" lock washers and 5/16" whiz nuts in the bottom two holes on both sides. Use 3/8-16 x 1 1/4" hex bolts with 3/8" lock washers and 1" nut plates in the other three. Insert nut plate in the hole exposed after bumper was removed. Tighten with Loctite Red. Do the same thing on the other side. Reinstall metal bumper with existing bolts.



24. Replace the air baffle using a 6MM-1 x 45MM hex bolt.

BE SURE TO USE LOCTITE® RED ON ALL BOLTS BEFORE TIGHTENING. TIGHTEN ALL BOLTS ACCORDING TO THE TORQUE CHART ON THE FRONT PAGE OF THESE INSTRUCTIONS OR ON PAGE 3 OF THE BASEPLATE TOWING GENERAL INSTRUCTIONS.

BX2712 2007 Kia Rondo Installation Instructions



25. Reconnect the washer reservoir using existing back bolts and a 6MM-1 x 30MM hex bolt with 5/16" flat and lock washer on the front (grey arrow). Reconnect hoses and wires. Reconnect wire loom to its original placement with a 6MM-1.0 x 30MM hex bolt with 5/6" flat and lock washer. Do this to both sides.
27. Reinstall transmission fluid line, fascia, bolts, push pins and screws.

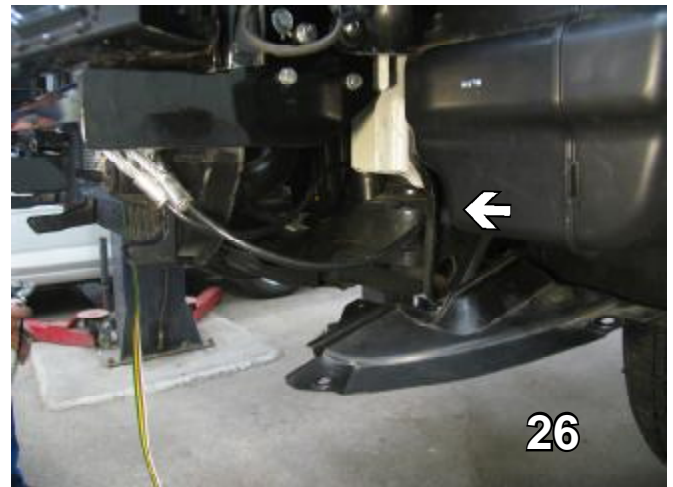

26. Attach baseplate safety cables around the lower frame extension, or as close as possible. If you are unable to place safety cables in this position, position the cables around a solid piece of the frame.

Be sure that **ALL** electrical connections are plugged in properly and functioning **BEFORE** installing the fascia.

BX2712 2007 Kia Rondo Installation Instructions

Install the tow bar and safety cables according to the instructions provided in their packages. When demonstrating this to the customer, be sure to include all the contents and packages.

Do **NOT** substitute other devices if the tow bar pins and clips are misplaced.

DEALER or INSTALLER:
Be certain the user receives the instruction sheets for their products.



Customer Service Commitment

Blue Ox® is focused on providing exemplary customer service, as observed in our mission statement and guiding principles. In accordance with this objective, Blue Ox® is proud to provide services such as repairs and general maintenance of Blue Ox® products at over 150 RV Rallies. Look for our Destination America or Blue Ox® Racing service crews at the next rally or race that you attend. If you were not present, you will find an informative, personalized note explaining any services that may have been performed to your Blue Ox® products.

Blue Ox® also offers educational seminars at rallies and through our Park and Resort teams. In addition, Blue Ox® customers visiting our factory may take advantage of the well-equipped Blue Ox® RV park at no charge to you, our valued and appreciated customer.



© 2007 Blue Ox
One Mill Road, Industrial Park
Pender, Nebraska 68047
Phone: (402) 385-3051 • Fax: (402) 385-3360
www.blueox.us