



BX3204 Installation Instructions 1992-97 Oldsmobile Achieva 1997 Buick Skylark

Utilization of Blue Ox baseplates with any tow bar not approved by Automatic Equipment Mfg. Company invalidates the limited warranty.

1. Read the General Instruction Sheet included with this baseplate.
2. The baseplate bolts to the bottom of the metal inner bumper and braces down to the frame using four bolts provided in the kit.
3. Below and behind the bumper there is a black plastic air dam. Remove the bolts (10mm wrench) and set the parts aside for later replacement.

Skylark

4. There are three screws on each end of the bumper that hold it to the fender well molding. Remove these so you are able to reach the bolts (use 10mm wrench, 10mm socket and long extension) that hold the bumper to each quarter panel.
5. There are two bolts that hold the grill (use 7mm wrench) to the frame. On the bottom of the grill, tabs slide into a slot. You can pop out the tabs with a screwdriver. Once the grill is off there are two pop rivets that need to be taken off, and two more on the underside of the bumper. Remove all the small bolts on the underside of the bumper (use a 7mm wrench) and remove the bumper.
6. Locate the center of the metal bumper and mark. The next steps will locate the holes front-to-back on the metal bumper.
7. Behind the air dam's mounting location there are two arms that are bolted to the frame with four bolts. Remove the inside bolt on each arm and set them aside, they will not be used to install the baseplate. Start the 12mm bolts and lock washers (Items 7 & 11) through the rear hole in the brackets (Item 3) and the spacers (Item 4) and into the frame where you removed the inside bolts on the arms. Loosely bolt the brackets (Item 3) to the baseplate (Item 1) using the 1/2 x 1 1/2 bolts and lock washers (Items 6 & 10) provided. The nuts are welded to the baseplate (see drawing on page two). Use Loctite, but do not tighten yet.

Achieva

8. Slide the baseplate up behind the bumper plastic and under the metal bumper. The tow bar tabs will stick out in front of the bumper.
9. Attach the two brackets (Item 3), as shown in the drawing on page two, to the baseplate (Item 1). Use the 1/2 x 1 1/2" bolts (Item 6) and the lock washers (Items 10). The other end of the braces will bolt to the two inside areas of the frame (see drawing on page two). Start the 12mm bolts and lock washers (Items 7 & 11) through the rear hole in the brackets (Item 3) and the spacers (Item 4) and into the frame where you removed the inside bolts on the arms. Use Loctite and snug the bolts, but do not tighten completely.

Both Models

10. Clamp the baseplate (Item 1) to the center of the frame. Once you have the baseplate in position drill a 17/32" hole using the holes of the baseplate as a template (see side diagram). Bolt the baseplate (Item 1) to the frame using the bolt plate (Item 2) and the 1/2" nut (Item 8) and 1/2" washers (Item 9 & 10). Be sure to use Loctite on all bolts and tighten.
11. Hold the air dam up in position. You will need to notch the air dam in two places to clear the brackets. With the notches cut, replace the air dam.

Skylark

12. Replace the bumper

Both Models

13. The dimensional variations between otherwise identical cars can be considerable. While the location and size of the holes in the baseplate were designed to allow for easy installation, it may be necessary to file a hole slightly to allow a bolt to clear.
14. Install the tow bar and safety cables according to the instructions included in their packages.

Automatic

15. Do not substitute other devices if the tow bar pin and clip are lost.

16. DEALER OR INSTALLER: BE CERTAIN THE USER RECEIVES THE INSTRUCTION SHEET.

Tools Required

10mm Wrench
3/4" Wrench
Drill

19mm Wrench
Utility Knife
17/32" Drill Bit

17mm Wrench
Loctite Blue

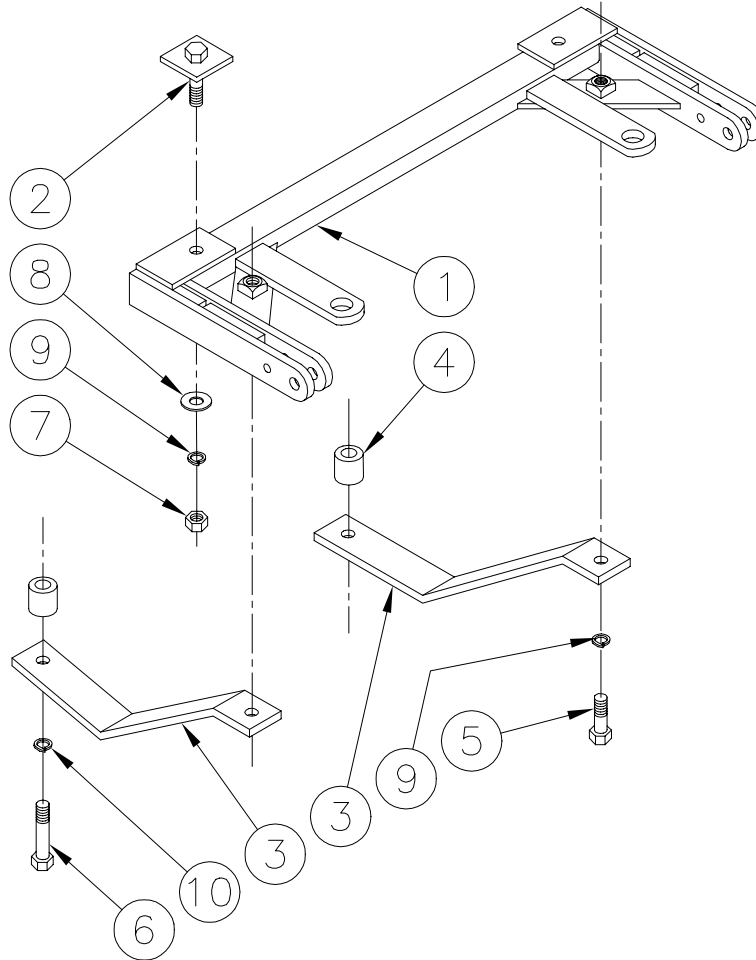

Parts List

| Ref. No. | Qty. | Part No. | Description |
|----------|------|----------|--------------------------------------|
| 1 | 1 | 61-4808 | Baseplate, BX3204 |
| 2 | 2 | 61-4809 | Bolt Assembly, BX3204 |
| 3 | 2 | 102-5108 | Frame Mounting Bracket, BX3204 |
| 4 | 2 | 107-2009 | Spacer, 1 1/8 Dia. x 1 1/8 |
| 5 | 2 | 201-0051 | 1/2-13 x 1-1/2 Hex Bolt, Grade 5 |
| 6 | 2 | 201-0590 | 12mm-1.75 x 65mm Hex Bolt, Grade 8.8 |
| 7 | 2 | 202-0005 | 1/2-13 Hex Nut |
| 8 | 2 | 203-0005 | 1/2 Flat Washer |
| 9 | 4 | 203-0012 | 1/2 Lock Washer |
| 10 | 2 | 203-0105 | 12mm Lock Washer |