



Baseplate Installation Instructions

BX3330

# 2007-10 Saturn Outlook Installation Instructions

Serial Number

Please read BOTH these Installation Instructions and the General Towing Instructions before attempting to install or operate this equipment.

1. Blue Ox® towing products and accessories are intended to be installed by Blue Ox® Dealers who are familiar with our products and have the equipment and knowledge to do “fit work.” When necessary, Blue Ox® Dealers can be found at [www.blueox.com](http://www.blueox.com) or by contacting our Customer Care Department at (402) 385-3051.

Attachment Tab Height: 16 1/2”  
Attachment Tab Width: 23”

2. Many Blue Ox® baseplates are designed to use existing holes and hardware to mount the baseplate to the towed vehicle. Even though bolts are there, do not assume they are adequate for baseplate mounting. Always use hardware supplied in the hardware kit or existing hardware specified in the Baseplate Towing Installation Instructions.

### Bolt Torque Specifications

Torque in Foot-Pounds for Metric Bolts

Bolt Size	Grade 8.8	Grade 10.9
6MM	6	8
8MM	16	22
10MM	31	40
12MM	54	70
14MM	89	117

Confirm the towability and pre-towing procedures for your vehicle with the owner’s manual or contact the vehicle’s manufacturer for specific towing procedures.

### Bolt Torque Specifications

Torque in Foot-Pounds for Inch Bolts

Bolt Size	Grade 5	Grade 8
1/4”	10	14
5/16”	19	29
3/8”	33	47
7/16”	54	78
1/2”	78	119
5/8”	154	230

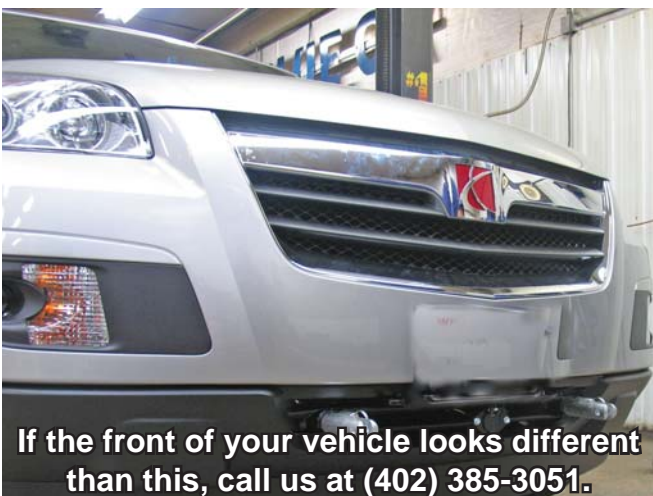

If the front of your vehicle looks different than this, call us at (402) 385-3051.

## WARNING

Failure to read and follow these instructions could result in separation of the towed vehicle from the tow bar, causing property damage, loss of towed vehicle, personal injury or death.

BX3330  
2007-10 Saturn Outlook  
Installation Instructions

## Parts List

Ref. No.	Qty.	Part #	Description
1	1	61-6364	Weldment, Baseplate, BX3330
2	4	201-0051	1/2-13 x 1 1/2" Hex Bolt, GRD. 5, ZP
3	4	203-0012	1/2" Lock Washer, ZP
4	4	61-4029	Weldment, 1/2" Nut Wire, Common
5	2	201-0553	1/4-20x1/2" Hex WSHD, Type F Screw
6	2	201-0192	#10-32x1/2" Slot, Round Head Screw
7	2	203-0054	#10 Lock Washer
8	2	202-0047	#10-32 Hex Nut
9	2	101-5822	Adapter, 4 Way Connector
10	2	62-3468	Attachment, Assembly, SF/SB, 1 Hole
	2	290-0437	Cap Plug, Black (Not Shown)
	2	229-0359	Quicklink, 3/8", ZP (Not Shown)
	2	226-0046	Baseplate Safety Cable, 36" Class III (Not Shown)
E	4		Existing Bolts

### Tools Required

Loctite® RED  
Phillips Screwdriver  
7MM Socket  
10MM Socket  
15MM Socket  
17/32" Drill Bit  
Reciprocating Saw  
Utility Knife

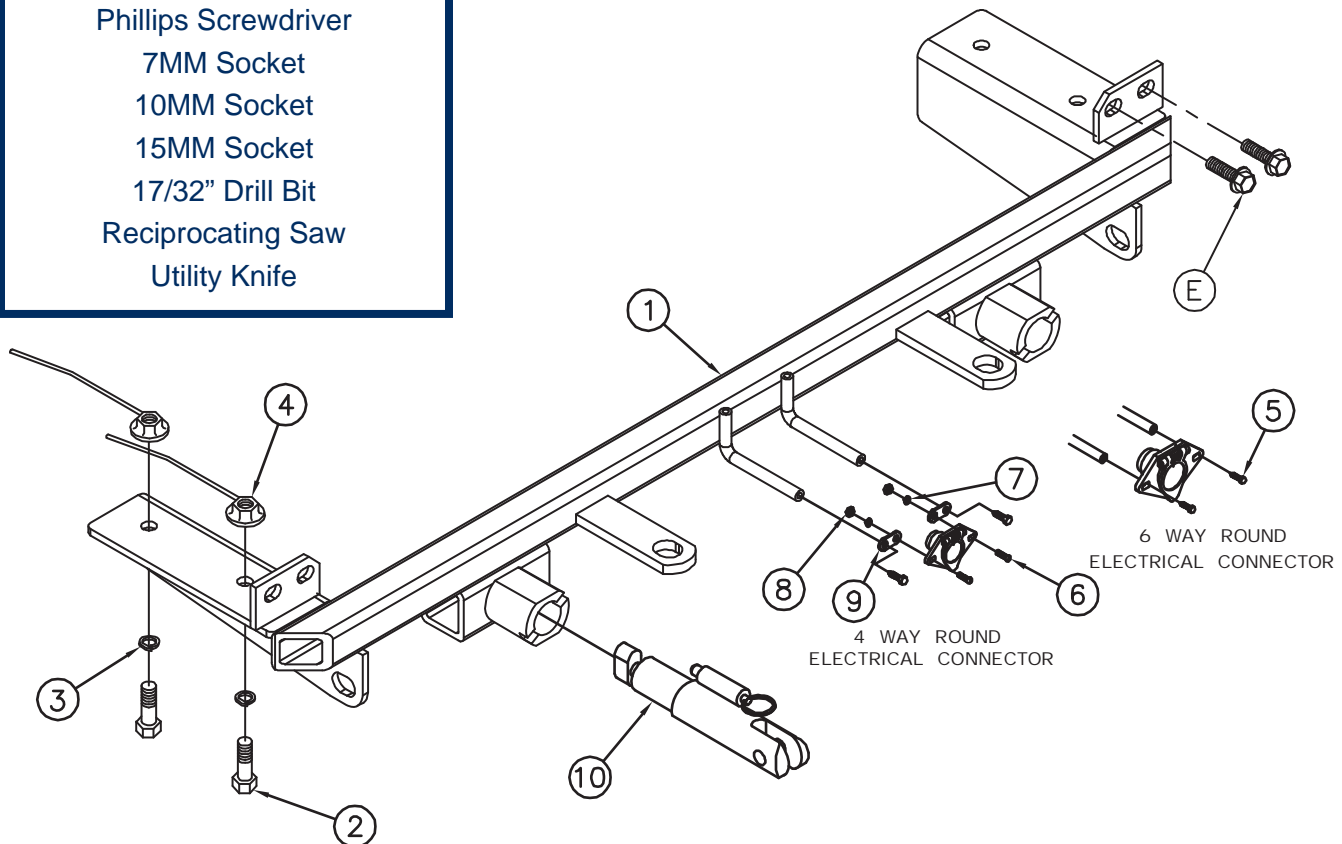

### Important:

Use only genuine factory replacement parts on your baseplate. Do **NOT** substitute homemade or non-typical parts. If a bolt is lost or in need of replacement, for your safety and the preservation of your baseplate, be sure to use a replacement bolt of the same grade (In most cases it will be Grade 5, please reference the parts list above). Replacement parts may be ordered through your nearest Blue Ox® Dealer or Distributor. Failing to follow and/or altering these installation instructions in either installation or required equipment will void the manufacturer's warranty.

BX3330

# 2007-10 Saturn Outlook

## Installation Instructions

### Attachment Tabs:

Due to the design of the removable tabs, the RangeFinder II and Ambassador tow bars can not be used. Adapters, except the BX8833 and BX88151, can be used with this baseplate.

**Installation Notes:** The fascia is removed and reinstalled during installation of the baseplate. Drilling is required. Trimming of the fascia is required.

The dimensional variations between otherwise identical vehicles can be considerable. While the baseplate was designed for easy installation, it may be necessary to tailor the baseplate slightly to compensate for auto manufacturer's tolerances. These minor adjustments may include filing a hole slightly, bending electrical rods or bending end plates.

The BX8869 Bulb and Socket Wiring Kit is recommended for this vehicle.



Handling of some cosmetic parts when installing this product may require the use of protective covers, rags, specialty tools, etc. to prevent damage.

### Installation Instructions:



1. Using a flat screwdriver, remove 4 push pins from the flat plastic piece on top. Do this to both sides of the vehicle. Set push pins aside to be reinstalled later.



BX3330  
2007-10 Saturn Outlook  
Installation Instructions

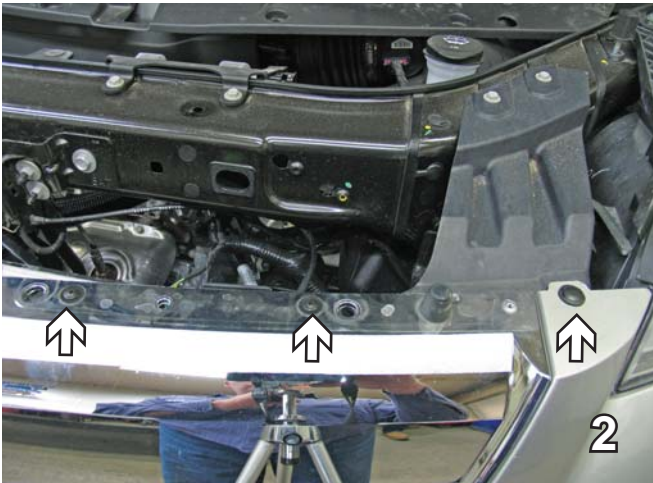

2. Using a phillips screwdriver, remove two phillips screws on top of the fascia and using a flat screwdriver, remove one pushpin from the top outside edge. Do this to both sides of the vehicle. Set screws and push pins aside to be reinstalled later.

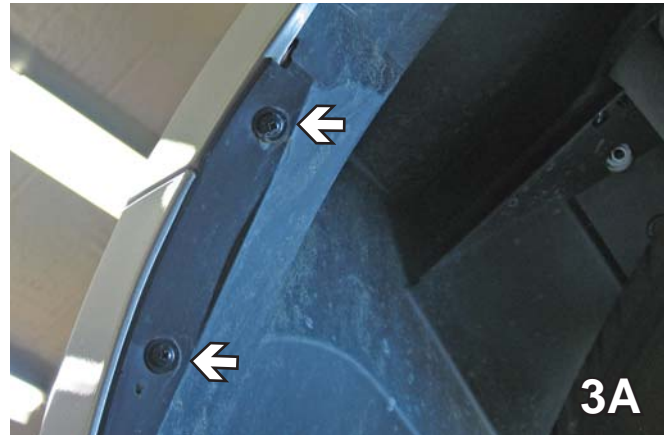

3. Using a phillips screwdriver, remove four phillips screws just forward of the front tire, on the wheel well. Set screws aside to be reinstalled later. Do this to both sides of the vehicle.



4. Using a phillips screwdriver, remove two screws from just forward of the front tire underneath. Set screws aside to be reinstalled later. Do this to both sides of the vehicle.



5. After removing the screws in Step 1 and 2, pull plastic back to get to a bolt. Using a 7MM socket, remove bolt and set aside to be reinstalled later. Do this to both sides of the vehicle.

BX3330  
2007-10 Saturn Outlook  
Installation Instructions

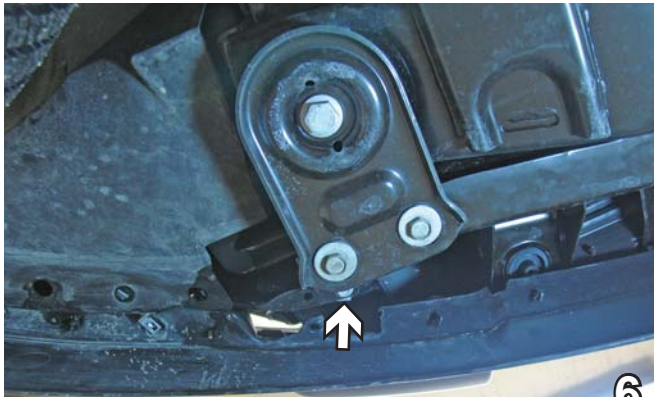

6. Using a 10MM socket, remove a bolt from the brace for the fog light. In the picture above, the bolt is hidden slightly (see white arrow). Set bolt aside to be reinstalled later. Do this to both sides of the vehicle. The fascia is then ready to be removed from the vehicle and carefully set aside to be reinstalled later.

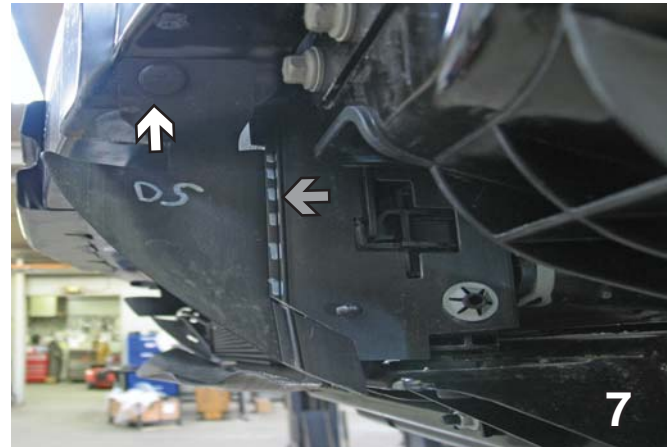

7. Using a flat screwdriver, remove pushpin (see white arrow) and then using a utility knife, cut along dashed line shown in the photo above (see grey arrow). The plastic piece will not be reinstalled and can be discarded. Do this to both sides of the vehicle.

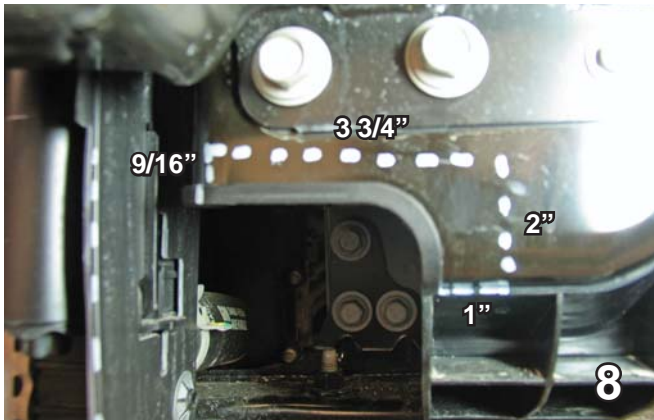

8. Mark and cut out frame according to the photo above, using a reciprocating saw. Do this to both sides of the vehicle.

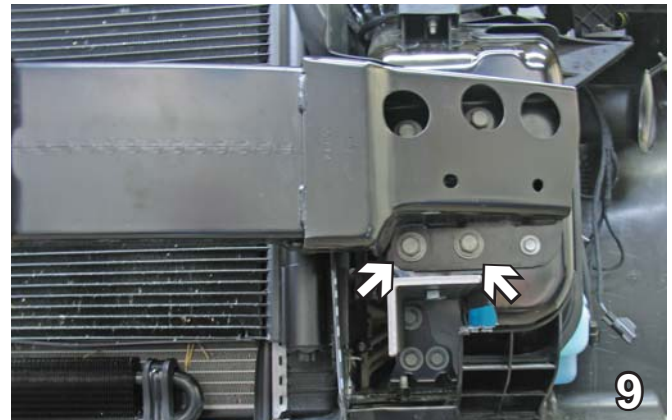

9. Using a 15MM socket, remove two bolts from the front of the bumper. Set bolts aside to be reinstalled later. Do this to both sides of the vehicle.

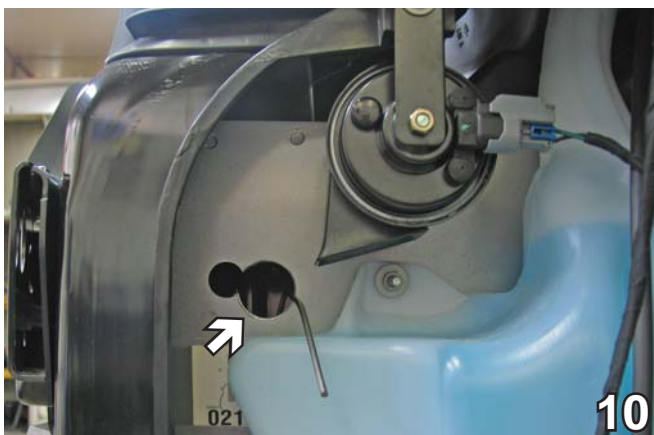

10. Drill a 1 1/4" hole into the frame, so the nut plates can go through. Do this to both sides of the vehicle.

When using power drills, be aware of the dangers of torque and drill bit length.



BX3330  
2007-10 Saturn Outlook  
Installation Instructions



11. Slide baseplate up, so it matches up with the existing holes of the bumper. Insert the existing bolts from the bumper and tighten them down with a 15MM socket so they are snug. Do this to both sides of the vehicle.



12. Using the baseplate as a template, drill the two bottom holes into the frame with a 17/32" drill bit. Insert the 1/2" nut plates into the frame and align with drilled holes. Insert a 1/2-13x1 1/2" hex bolt and 1/2" lock washer into each hole and tighten down with a 3/4" socket. Do this to both sides of the vehicle.



13. Attach permanent baseplate safety cables to the convenience link on the baseplate (see photo 12A). Photo 12B shows recommended installation of the cables to frame of vehicle. If vehicle has additional options (not shown above) which interfere with mounting permanent baseplate safety cables, secure the cables to a solid piece of the vehicle frame as described in instructions included with the permanent baseplate safety cables.

**BE SURE TO USE LOCTITE® RED ON ALL BOLTS BEFORE TIGHTENING. TIGHTEN ALL BOLTS ACCORDING TO THE TORQUE CHART ON THE FRONT PAGE OF THESE INSTRUCTIONS OR ON PAGE 3 OF THE BASEPLATE TOWING GENERAL INSTRUCTIONS.**



14. Align the fascia to its original position, and using a hack saw knife, trim out the opening in the grille for the attachment tabs, using the photo above as a template. Do this to both sides of the vehicle.

**Be sure that ALL electrical connections are plugged in properly and functioning BEFORE installing the fascia.**

BX3330

# 2007-10 Saturn Outlook

## Installation Instructions

Install the tow bar and safety cables according to the instructions provided in their packages. When demonstrating this to the customer, be sure to include all the contents and packages.

Do **NOT** substitute other devices if the tow bar pins and clips are misplaced.

**DEALER or INSTALLER:**  
Be certain the user receives the instruction sheets for their products.

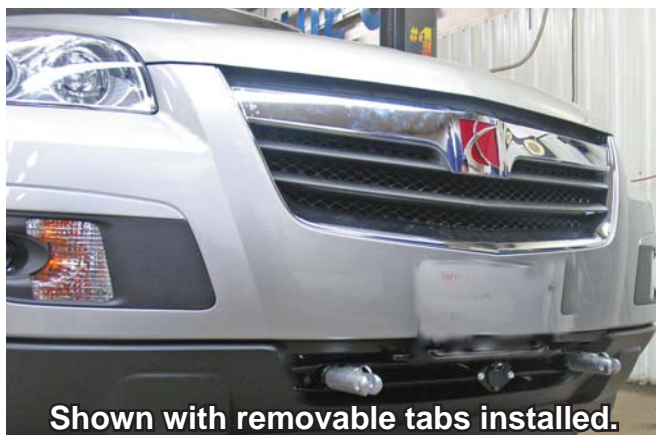

If the baseplate is in an accident, it must be replaced. **DO NOT** use it again! An accident can cause unseen damage and using it again could result in more damage or serious injury. **DO NOT** use the baseplate if it is damaged or missing parts.

### CUSTOMER SERVICE COMMITMENT

Blue Ox is committed to providing you with exceptional customer care throughout your lifetime with our products. Our team is here to assist you with any questions you may have regarding the performance of your product. Simply call 1-800-228-9289 and you can speak with our customer care team.

Additionally, please visit our website to see which rallies our Destination America team will be attending. For a nominal fee, our service technician will service your towing system to ensure it's in proper working condition. Also, as a commitment to our customers, should you visit our factory you can stay at our full service Blue Ox campground at no charge along with enjoying a factory tour.

Again, thank you for being our customer and for the confidence you have shown in the performance of our products. It is because of customers like you we enjoy the success we have today.



© 2007, 08, 11 Blue Ox  
One Mill Road, Industrial Park  
Pender, Nebraska 68047  
Phone: (402) 385-3051 • Fax: (402) 385-3360  
www.blueox.com