



BLUE OX®

Baseplate Installation Instructions

BX3335

2006-07 Saturn Vue No Red Line Edition

Installation Instructions

Serial Number

Please read BOTH these Installation Instructions and the General Instructions before attempting to install or operate this equipment.

- Blue Ox® towing products and accessories are intended to be installed by Blue Ox® Dealers who are familiar with our products and have the equipment necessary and knowledge to do "fit work". When necessary Blue Ox® Dealers can be found at www.blueox.com or by contacting our Customer Care Department at (402) 385-3051.
- Many Blue Ox® Baseplates are designed to use existing holes and hardware to mount the baseplate to the towed vehicle. Even though bolts are there, do not assume they are adequate for baseplate mounting. Always use hardware supplied in the hardware kit and existing hardware specified in the Baseplate Installation Instructions.

Attachment Tab Height: 15"

Attachment Tab Width: 18"

Bolt Torque Specifications

Torque in Foot-Pounds for Metric Bolts

Bolt Size	Grade 8.8	Grade 10.9
6MM	6	8
8MM	16	22
10MM	31	40
12MM	54	70
14MM	89	117

Confirm the towability and pre-towing procedures for your vehicle with the owner's manual or contact the vehicle's manufacturer for specific towing procedures.

Bolt Torque Specifications

Torque in Foot-Pounds for Inch Bolts

Bolt Size	Grade 5	Grade 8
1/4"	10	14
5/16"	19	29
3/8"	33	47
7/16"	54	78
1/2"	78	119
5/8"	154	230



If the front of your vehicle looks different than this, call us at (402) 385-3051.

⚠ WARNING

Failure to read and follow these instructions could result in separation of the towed vehicle from the tow bar, causing property damage, loss of towed vehicle, personal injury or death.

BX3335

2006-07 Saturn Vue

No Red Line Edition

Installation Instructions

Parts List

Ref. No.	Qty.	Part #	Description
1	1	61-6780	Weldment, Base Plate, BX3335
2	6	61-5208	3/8-16 Nut Plate
3	6	201-0444	3/8-16 x 2 Bolt, Grade 5, ZP
4	6	203-0010	3/8 Lock Washer, ZP
5	2	201-0553	1/4-20 x 1/2" Hx. Wshd, Type F Screw
6	2	201-0192	#10-32 x 1/2" Slot Rd. Hd. Screw
7	2	203-0054	#10 Lock Washer
8	2	202-0047	#10-32 Hex Nut
9	2	101-5822	Adapter, 4 Way Connector
10	2	62-3468	Attachment, Assembly SB/SF (R)
	1	101-6845	Electrical Bracket (Not Shown)
	2	226-0046	Baseplate Safety Cable, 36" CL III (Not Shown)
	4	229-0359	Quicklink, 3/8, ZP (Not Shown)
	2	290-0437	Cap Plug Receiver (Not Shown)

Tools Required

- 7MM Socket
- 10MM Socket
- 9/16" Socket
- Large Vise Grips
- Reciprocating Saw
- Drill
- Flat Screwdriver
- Utility Knife
- Torque Wrench
- Tape Measure
- 13/32" Drill Bit
- Loctite® RED

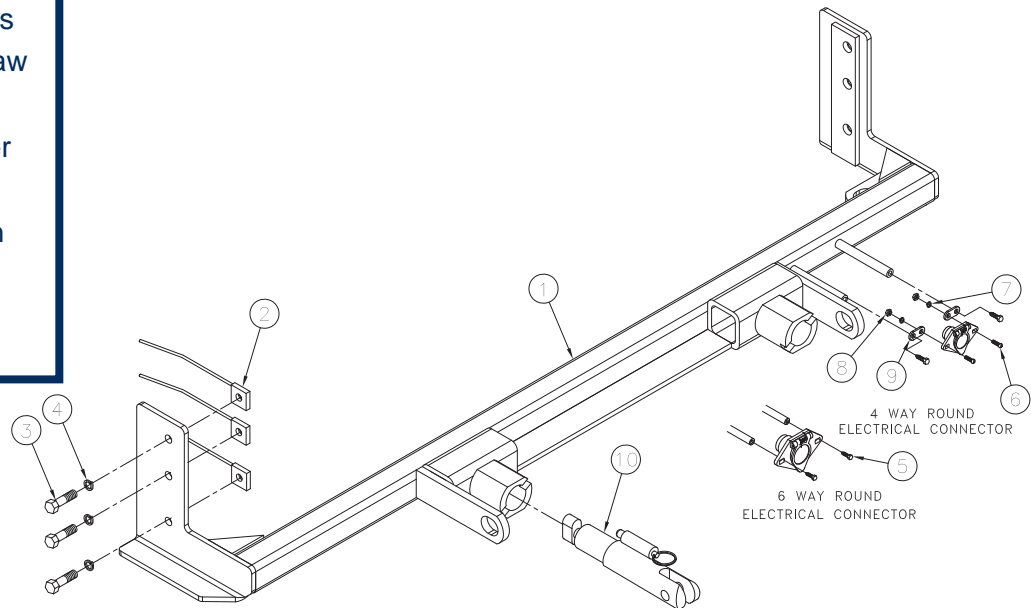

Important:

Use only genuine factory replacement parts on your baseplate. Do NOT substitute homemade or non-typical parts. If a bolt is lost or in need of replacement, for your safety and the preservation of your baseplate, be sure to use a replacement bolt of the same grade (In most cases it will be Grade 5, please reference the parts list above). Replacement parts may be ordered through your nearest Blue Ox® Dealer or Distributor, or call our Customer Care Team at (402)385-3051. Failing to follow and/or altering these installation instructions in either installation or required equipment will void the manufacturer's warranty. Towing behind a non-motorized vehicle will void the warranty.

BX3335

2006-07 Saturn Vue

No Red Line Edition

Installation Instructions

Attachment Tabs:

Motorhome mount tow bars are recommended for use with this baseplate. Due to the design of the removable tabs, the RangeFinder II, Adventurer and Ambassador tow bars can not be used. The Acclaim tow bar may be used, but will not fold and store on the front of the vehicle. Adapters, except the BX8833 and BX88151, can not be used with this baseplate.

Instructions:

The front fascia and styrofoam bumper are removed and reinstalled during the baseplate installation. Drilling is required. Trimming of the bumper bracket and styrofoam bumper is required.

Some vehicles fascias may need trimming. The dimensional variations between otherwise identical vehicles can be considerable. While the baseplate was designed for easy installation, it may be necessary to tailor the baseplate slightly to compensate for auto manufacturer's tolerances. These minor adjustments may include filing a hole slightly, bending electrical rods, or bending end plates.

The BX8869 Bulb and Socket Wiring Kit is recommended for this vehicle.



Installation Instructions:



1. Remove four metric bolts with hood bumpers from the top side of the front fascia using a 7MM socket. Set aside to be reinstalled later.



2. Just forward of the front tires, on the edge of the wheel well, remove five push pins. Set aside to be reinstalled later. This is done to both sides of the vehicle, the driver's side is shown.

Handling of some cosmetic parts when installing this product may require the use of protective covers, rags, specialty tools, etc. to prevent damage.

BX3335
2006-07 Saturn Vue
No Red Line Edition
Installation Instructions



3. Pull wheel well cover back and remove one metric bolt from the fascia's corner using a 10MM socket. Set aside to be reinstalled later. This is done on both sides, the driver's side is shown.

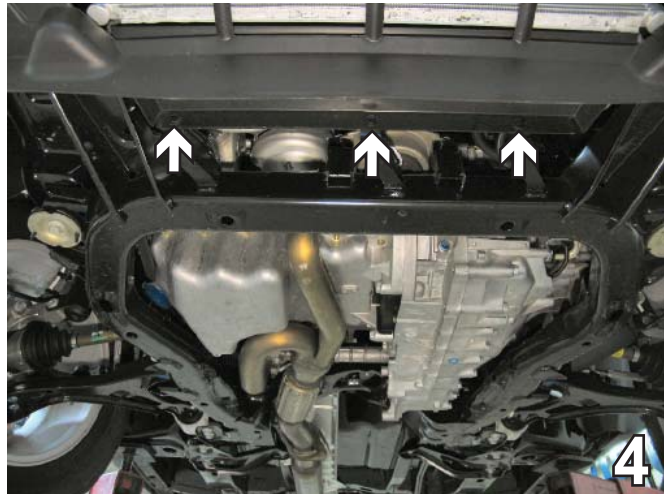

4. Remove three push pins from lower edge of fascia, just behind fascia's lower air dam. Set aside to be reinstalled later.

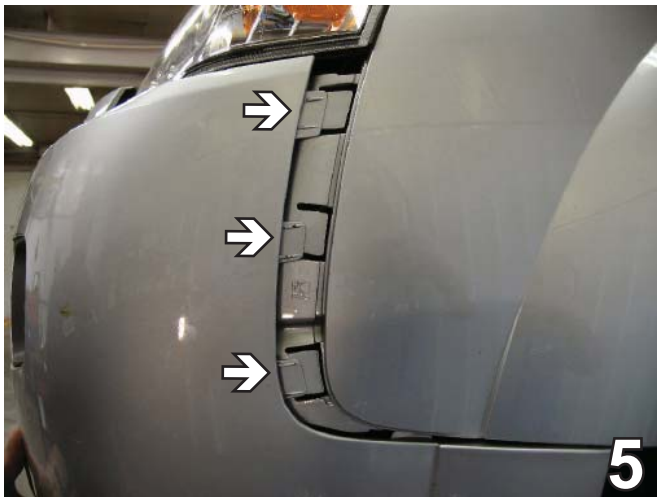

5. Locate the three clips behind fascia, just forward of the front tire, inside wheel well. While pulling the fascia forward, release the clips-starting with the lower one and working your way up-by pulling the clips toward the radiator with a small flat screwdriver. Do this to both sides of the vehicle, the driver's side is shown. **BE CAREFUL! DO NOT BREAK OFF FASCIA'S CLIPS.** Pull fascia forward, unplug the electrical connections if vehicle has fog/ running lights, and set the fascia aside carefully to be reinstalled later..

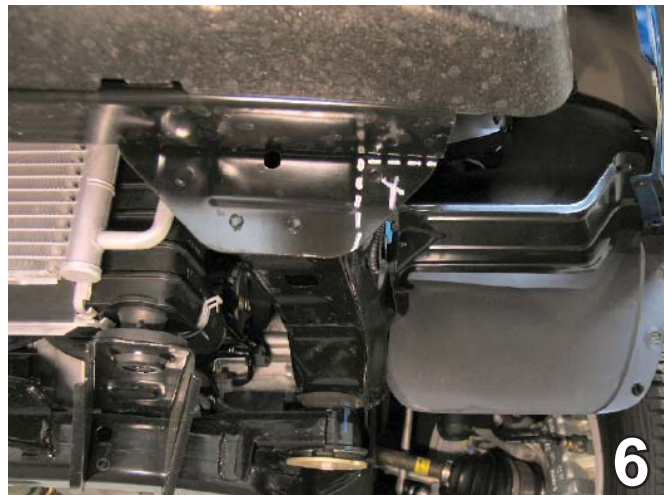

6. Using a reciprocating saw, make a horizontal cut just below the metal bumper on the bumper bracket into the outside edge of the frame. Do this on both sides of the vehicle. Make a vertical cut on the bumper bracket flush with the outside of the frame channel. Do this on both sides of the vehicle. **BE sure NOT to cut into the frame channel with either of these cuts.** This will open the area to prepare it for baseplate installation. The driver's side is shown.

When using power drills be aware of the dangers of torque and drill bit length.

BE SURE TO USE LOCTITE® RED ON ALL BOLTS BEFORE TIGHTENING. TIGHTEN ALL BOLTS ACCORDING TO THE TORQUE CHART ON THE FRONT PAGE OF THESE INSTRUCTIONS OR ON PAGE 3 OF THE BASEPLATE TOWING GENERAL INSTRUCTIONS.

BX3335

2006-07 Saturn Vue

No Red Line Edition

Installation Instructions



7. Remove two large push pins from the Styrofoam bumper. Set Styrofoam and push pins aside to be reinstalled later.



8. Slide the baseplate onto the outside of the frame rail just behind bumper bracket and up as far as possible. Clamp the baseplate to the end of the metal bumper on both sides of the vehicle. Using the baseplate as a template, drill three holes into the side of the frame rail with the 13/32" drill bit. Do this to both sides, the driver's side is shown.

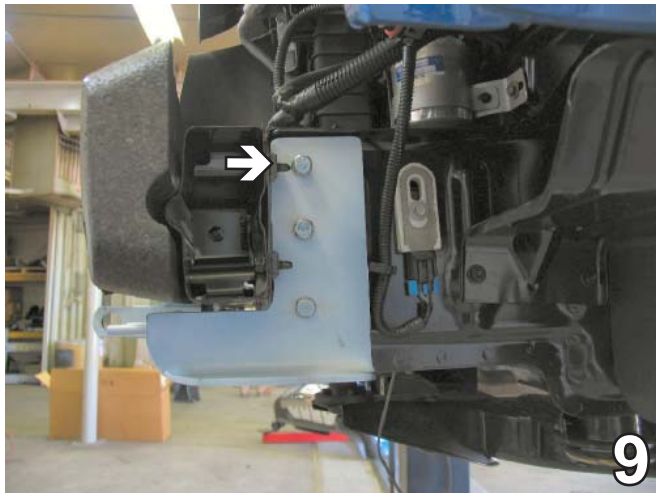

9. Locate the square opening on the bottom side of the frame rail. Insert the 3/8-16 nut plate with the wire into the square opening and align with drilled holes inside the frame. Insert 3/8-16 x 2" hex bolts and 3/8" lock washers into baseplate holes and tighten into nut plates. Do this to both sides, the driver's side is shown.

10. Attach the permanent baseplate safety cables to the provided convenience link on the baseplate. Secure the cables to a solid piece of the frame as described in the instructions included with the permanent baseplate safety cables, additional options may interfere with suggested mounting. Be sure the safety cables do not rub against any hoses or moving parts. Do this to both sides of the vehicle.

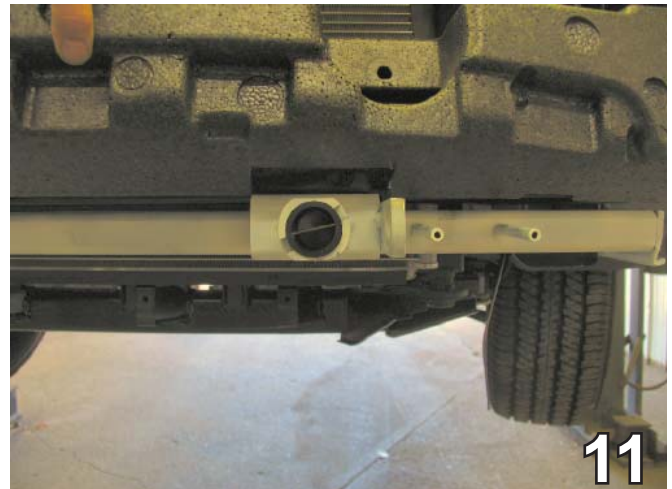

11. With baseplate installation completed, set Styrofoam as close to its original position as possible. Mark and cut the bottom of the Styrofoam 1/2" deep around the attachment tab receiver area with a utility knife and remove this portion of the Styrofoam. This is done to both sides of the vehicle, the driver's side is shown. Reinstall Styrofoam with the existing two large push pins.

Be sure that ALL electrical connections are plugged in properly and functioning BEFORE installing the fascia.

12. Reinstall the fascia.

BX3335
2006-07 Saturn Vue
No Red Line Edition
Installation Instructions

Install the tow bar and safety cables according to the instructions provided in their packages. When demonstrating this to the customer, be sure to include all the contents and packages.

Do **NOT** substitute other devices if the tow bar pins and clips are misplaced.



If the baseplate is in an accident, it must be replaced. DO NOT use it again! An accident can cause unseen damage and using it again could result in more damage or serious injury. DO NOT use the baseplate if it is damaged or missing parts.

DEALER or INSTALLER:
Be certain the user receives the instruction sheets for their products.

CUSTOMER SERVICE COMMITMENT

Blue Ox is committed to providing you with exceptional customer care throughout your lifetime with our products. Our team is here to assist you with any questions you may have regarding the performance of your product. Simply call (402) 385-3051 and you can speak with our customer care team.

Additionally, please visit our website to see which rallies our Destination America team will be attending. For a nominal fee, our service technician will service your towing system to ensure it's in proper working condition. Also as a commitment to our customers, should you visit our factory you can stay at our full service Blue Ox campground at no charge along with enjoying a factory tour.

Again thank you for being our customer and for the confidence you have shown in the performance of our products. It is because of customers like you we enjoy the success we have today.



© 2010 Blue Ox
One Mill Road, Industrial Park
Pender, Nebraska 68047
Phone: (402) 385-3051
Toll Free: (888) 425-5382
Fax: (402) 385-3360
www.blueox.com