



# BX3617

## 2011-14 Subaru Outback Installation Instructions

Serial Number

**Attachment Tab Height: 17"**

**Attachment Tab Width: 24"**

**Please read BOTH these Installation Instructions and the General Instructions prior to installing or operating this equipment.**

- Blue Ox® towing products and accessories are intended to be installed by Blue Ox® Dealers who are familiar with our products and have the equipment and knowledge necessary to do "fit work". If needed, Blue Ox® Dealers can be found at [www.blueox.com](http://www.blueox.com) or by contacting our Customer Care Department at (402) 385-3051.
- Many Blue Ox® baseplates are designed to use existing holes and hardware to mount the baseplate to the towed vehicle. Even though bolts are there, do not assume they are adequate for baseplate mounting. Always use the hardware supplied in the hardware kit and existing hardware as specified in the installation instructions.

**Bolt Torque Specifications**  
Torque in Foot-Pounds for Inch Bolts

Bolt Size	Grade 5	Grade 8
1/4"	10	14
5/16"	19	29
3/8"	33	47
7/16"	54	78
1/2"	78	119
5/8"	154	230
3/4"	257	380



**Bolt Torque Specifications**  
Torque in Foot-Pounds for Metric Bolts

Bolt Size	Grade 8.8	Grade 10.9
6MM	6	8
8MM	16	22
10MM	31	40
12MM	54	70
14MM	89	117
16MM	161	230
18MM	222	318

If the front of your vehicle looks different than this, please contact us at (402)385-3051.

**Reference your vehicle owner's manual for manufacturer's towing specifications.**

WARNING

Failure to read and follow these instructions could result in separation of the towed vehicle from the tow bar, causing property damage, loss of towed vehicle, personal injury or death.

# BX3617

## 2011-14 Subaru Outback

### Installation Instructions

#### Parts List

Ref. No.	Qty.	Part #	Description
1	1	61-6684	BX3617 BASEPLATE
2	6	61-5208	WLD, NUT PLT, 1/4X1X1, 3/8"/14"WIRE
3	2	107-1753	SPACER TUBE, 3/4 OD X .406 IDX 3/4"
4	4	201-0440	3/8-16 X 1 1/2 HEX BOLT, GRD.5, ZP
5	2	201-0444	3/8-16 X 2 HEX BOLT GRADE 5 ZP.
6	6	203-0010	3/8 LOCK WASHER, ZP
7	2	201-0553	1/4-20 X 1/2 HX.WSHD.TYPE F TCS, ZP
8	2	201-0192	10-32 X 1/2 SLOT, RD. HD. SCREW
9	2	203-0054	#10 LOCK WASHER
10	2	202-0047	#10-32 HEX NUT
11	2	101-5822	ADAPTER, 4 WAY CONNECTOR
12	2	62-3468	ATT TAB ASSY, REM, SF/SB, 1 HOLE
13	1	102-7056	BREAKAWAY / COOLANT BRACKET
14	2	201-0050	1/4-20 X 3/4 HEX BOLT GRD.5, ZP
15	2	202-0102	1/4-20 HEX NYL NUT, ZP
	2	226-0046	BASEPLATE SAFETY CABLE, 36" CL III (Not Shown)
	2	229-0359	QUICKLINK, 3/8, ZP (Not Shown)
	2	290-0437	RECEIVER, CAP PLUG (BLK) (Not Shown)
	1	201-0654	#10-16 X 1 SELF-DRILLING SCREW (Not Shown) *

#### Tools Required

12MM Socket	Phillips Screw Driver
9/16" Socket	Utility Knife
Large Vise Grip	1 1/4" Hole Saw
Drill	13/32" Drill Bit
Flat Screwdriver	Loctite® RED

\* **NOTE - 2012 -13 MODELS ONLY:** Baseplates manufactured November 1, 2011 and later will include the #10-16 X 1 Self-Drilling Screw. Should you require this hardware for installation of the baseplate on a 2012 Subaru Outback, please contact Blue Ox Manufacturing Customer Care Department at (402) 385-3051.

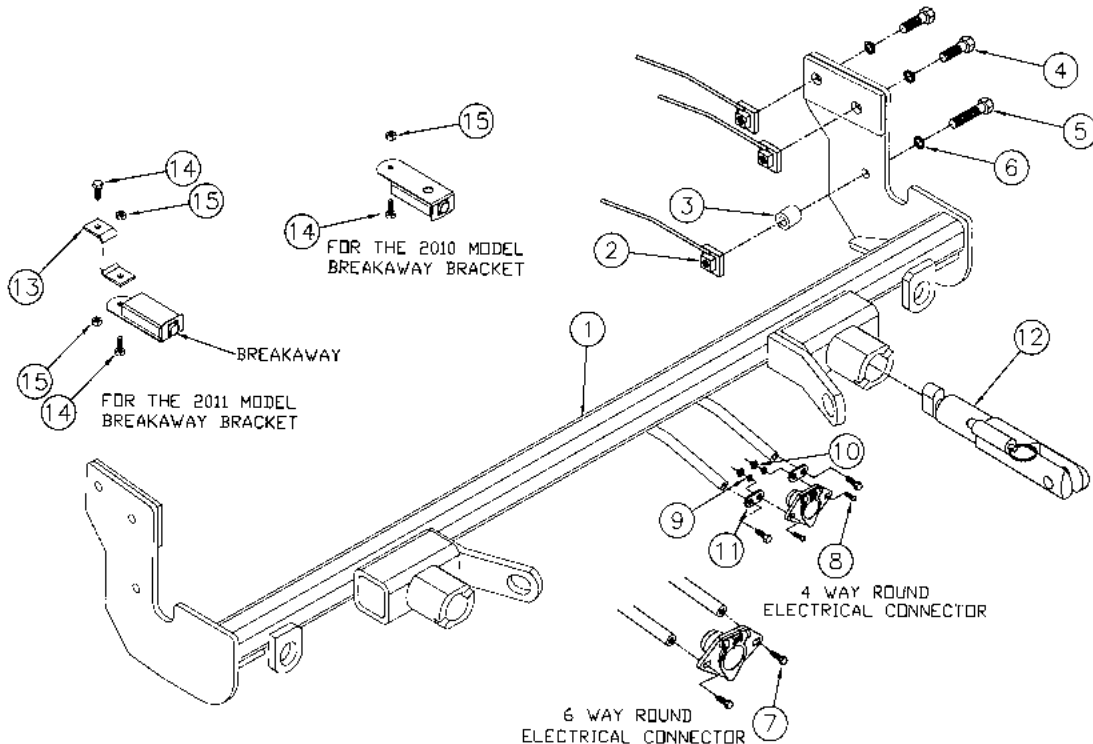

#### Important:

Use only genuine factory replacement parts on your baseplate. Do **NOT** substitute homemade or non-typical parts. If a bolt is lost or in need of replacement, for your safety and the preservation of your baseplate, be sure to use a replacement bolt of the same grade (In most cases it will be Grade 5, please reference the parts list above). Replacement parts may be ordered through your nearest Blue Ox® Dealer or Distributor. Failing to follow and/or altering these installation instructions in either installation or required equipment will void the manufacturer's warranty. Towing behind a non-motorized vehicle will void the warranty.

BX3617  
2011-14 Subaru Outback  
Installation Instructions

**Vehicle Weight:** Due to the design of the removable tabs, the RangeFinder II tow bar can not be used. Adapters, except the BX8833 and the BX88151, can not be used with this baseplate.

**Installation Notes:** The front fascia, headlight assembly and metal bumper are removed and reinstalled during installation of the baseplate. Temperature sensor is relocated. Drilling is required. Trimming of the air dam is required.

The dimensional variations between otherwise identical vehicles can be considerable. While the baseplate was designed for easy installation, it may be necessary to tailor the baseplate slightly to compensate for auto manufacturer's tolerances. These minor adjustments may include filing a hole slightly, bending electrical rods or bending end plates.

The BX8869 Bulb and Socket Wiring Kit is recommended for this vehicle.

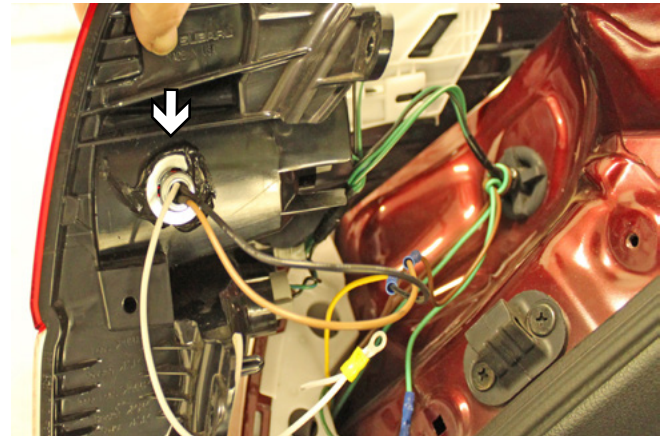

Possible location for the Bulb and Socket Wiring Kit (BX8869).

Handling of some cosmetic parts when installing this product may require the use of protective covers, rags, specialty tools, etc. to prevent damage.

Do not use the towed vehicle for storing luggage, equipment, etc. This may cause you to exceed the towing capacity of the tow bar, baseplate, and its accessories.

## Installation Instructions:

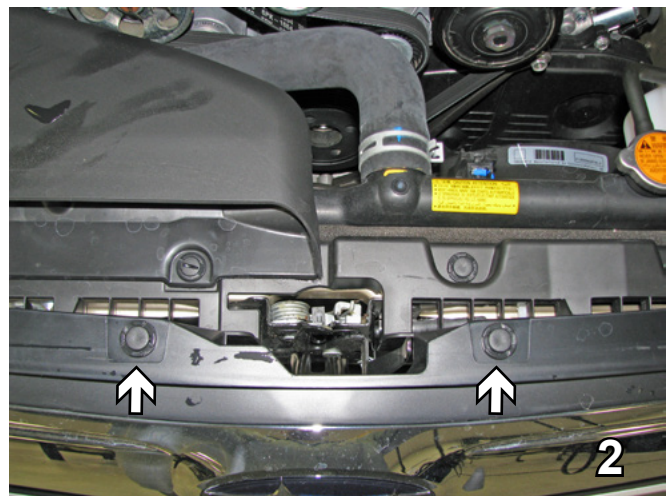
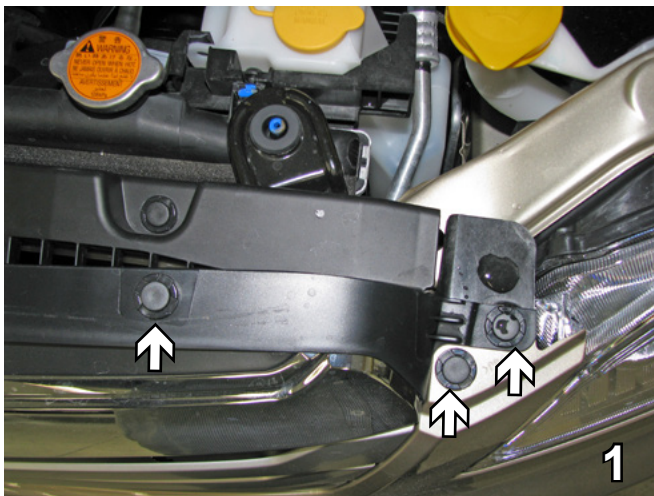

1. Using a flat screwdriver remove the three push pins from the flat top edge of fascia. Do this on both sides. Set push pins aside to be reinstalled later.
2. Using a flat screw driver, remove the two push pins from the center of the fascia. Set aside for later reinstallation.



BX3617  
2011-14 Subaru Outback  
Installation Instructions

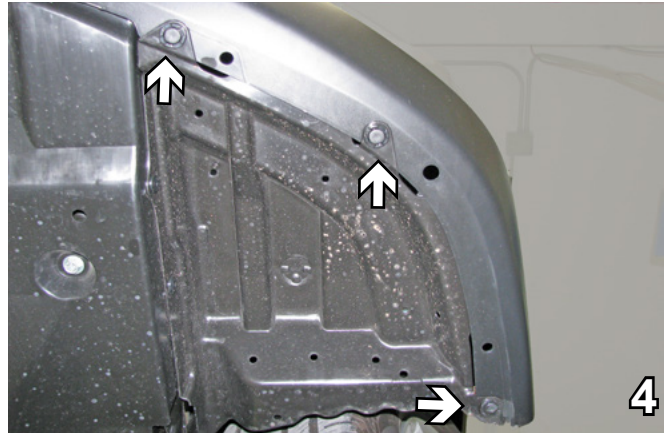

3. Underneath in front of the tire, use a flat screw driver to remove the push pin in the corner. Do this to both sides and set aside for later reinstallation.
4. Using a flat screwdriver, remove three push pins from up underneath. Do this on both sides. Set push pins aside for later reinstallation.



5. Remove the push pin from the tab on the lower edge of the fascia. Do this on both sides. Set push pins aside for later reinstallation.
6. Remove push pin from the tab on the lower center edge of the fascia. Set aside for later reinstallation.

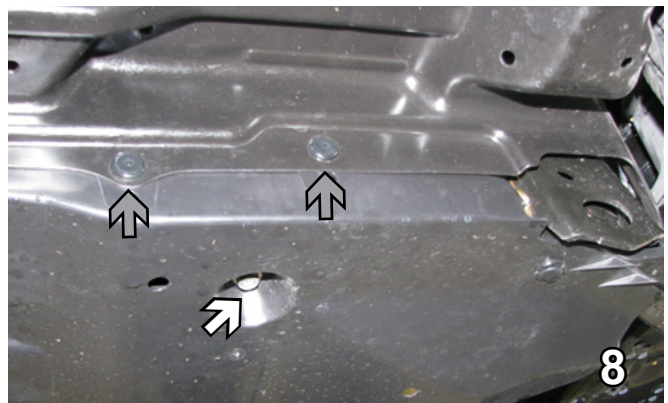

7. If the vehicle is equipped with foglights, disconnect them. Pull fascia corners out to the side of vehicle on both sides, then pull fascia forward and set it aside carefully for later reinstallation.
8. Using the 12MM socket, remove the bolt (white arrow) from underneath the air dam. On the side above (gray arrows), remove two Phillips push pins. Do this on both sides. Set bolt and push pins aside for later reinstallation.



BX3617  
2011-14 Subaru Outback  
Installation Instructions

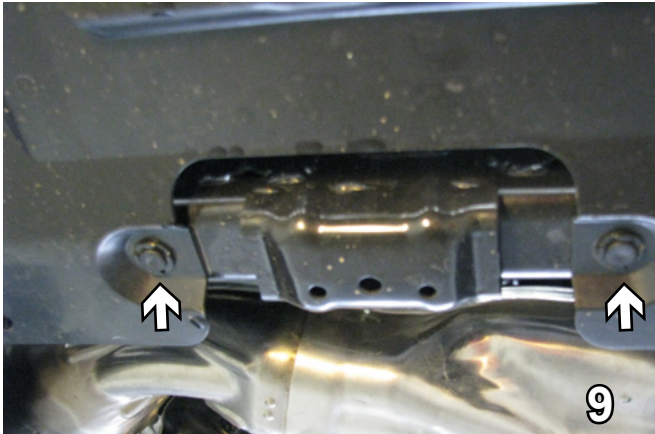

9. In the middle under the vehicle, remove two push pins. The cover will now hang out of the way in order to get the baseplate in underneath it. Set the push pins aside for later reinstallation.

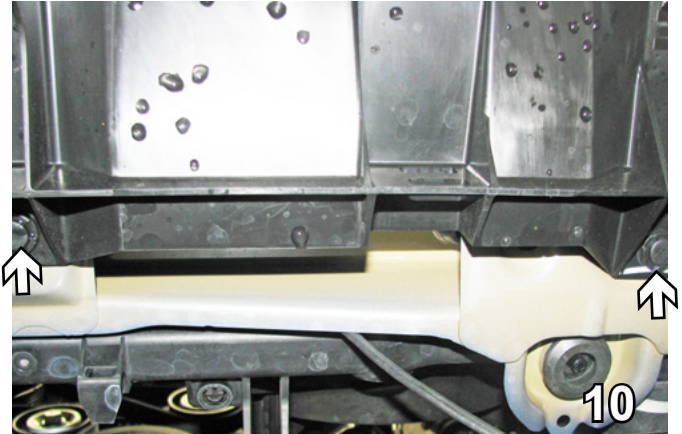

10. Underneath the cover in order to remove the air dam, remove three push pins. One on each side and one in the middle. Set the push pins aside for later reinstallation.

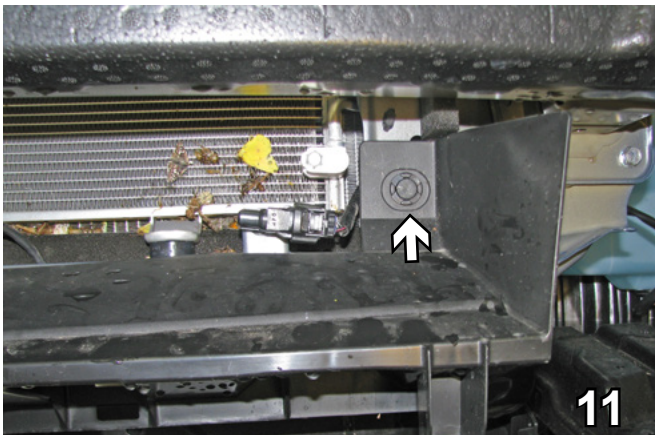

11. On the front of the air dam, remove three push pins one on each side and one in the middle. Set the push pins aside for later reinstallation. The middle pin will not be reattached.

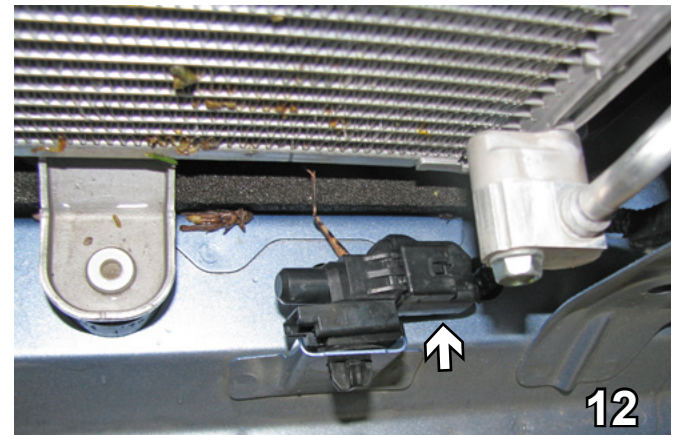

12. Relocate the temperature sensor to the backside of the bracket.

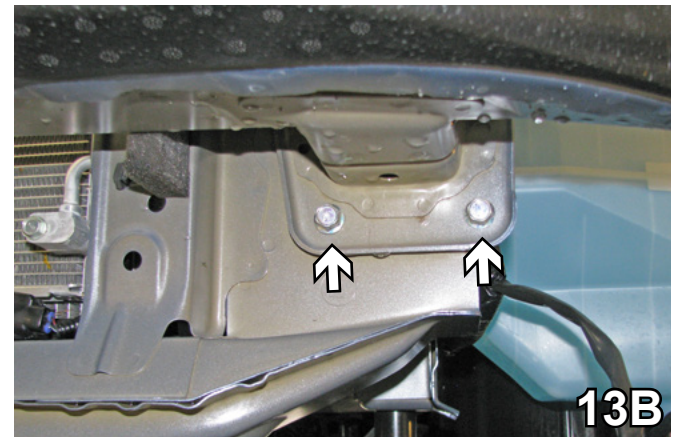
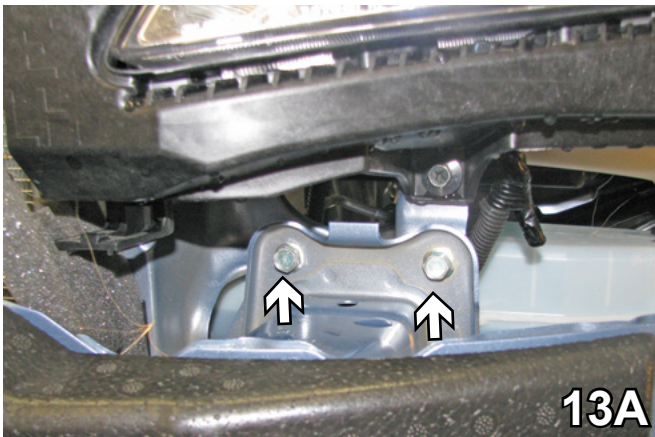

13. Using a 12MM socket, remove four metric bolts from the metal bumper, two on the top and two on the bottom. Do this on both sides. Pull the bumper forward and set it and the bolts aside to be reinstalled later.



BX3617  
2011-14 Subaru Outback  
Installation Instructions

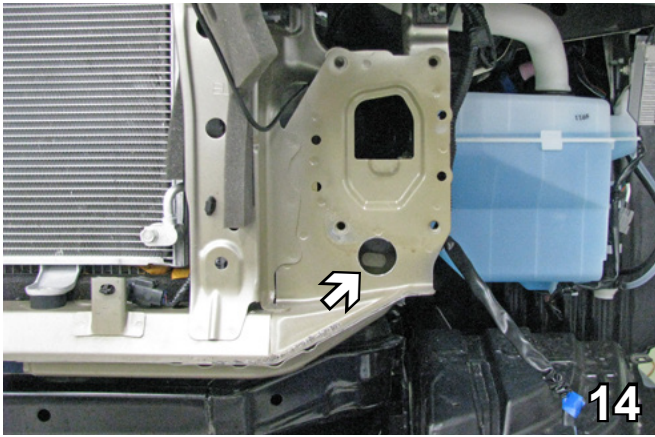

14. Using the 1 1/4" hole saw, drill out the existing larger hole in the frame rail. Do this on both sides.

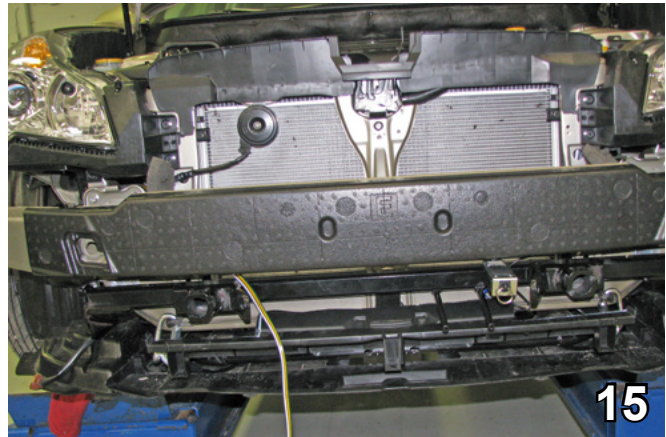

15. **2010 Model:** Hold the baseplate up in front of the air dam. Using the baseplate as a template, mark and cut where necessary using a utility knife.

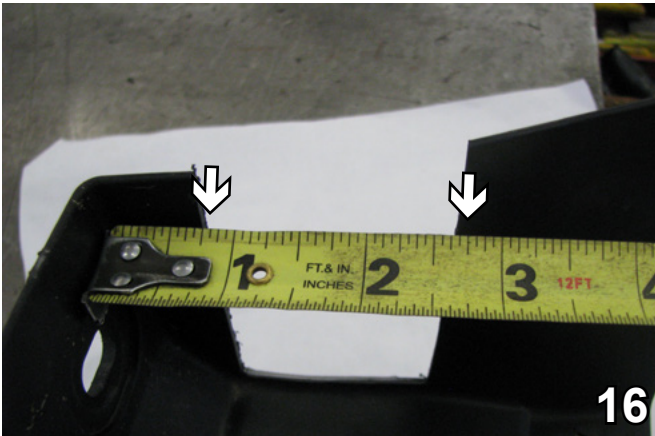

16. **2011 thru 2013 Models:** Trim starting 3/4" over from the enclosed corner straight down to the edge. Go over to 2 3/4" and cut straight down, then across removing this section. Do this on both sides.

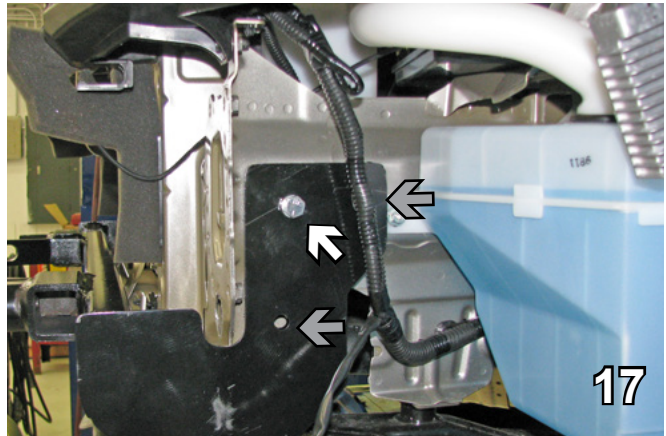

17. Slide the baseplate up to align with existing hole on the frame. Be sure the baseplate is level with the vehicle. Start 3/8-16 x 1 1/2" bolts in existing hole (white arrow) with lock washers and attach to 3/8-16 nut plates. Use Loctite and tighten. Using the baseplate as a template, with a 13/32" drill bit, drill out the existing hole (gray arrow) on top. Drill the hole on the bottom (gray arrow). Do this on both sides.

**When using power drills be aware of the dangers of torque and drill bit length.**

**BE SURE TO USE LOCTITE® RED ON ALL BOLTS BEFORE TIGHTENING. TIGHTEN ALL BOLTS ACCORDING TO THE TORQUE CHART ON THE FRONT PAGE OF THESE INSTRUCTIONS OR ON PAGE 3 OF THE BASEPLATE TOWING GENERAL INSTRUCTIONS.**

BX3617  
2011-14 Subaru Outback  
Installation Instructions

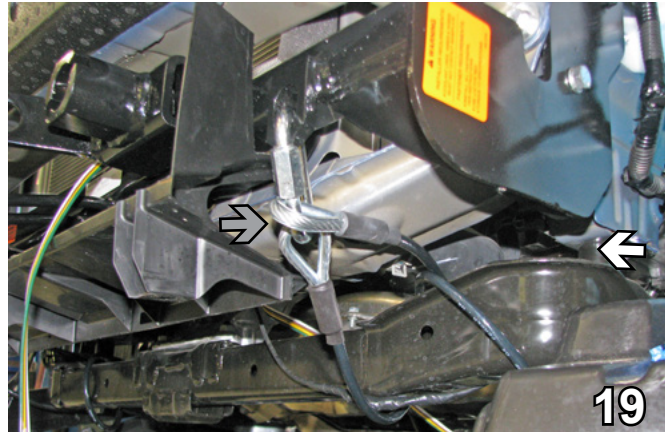
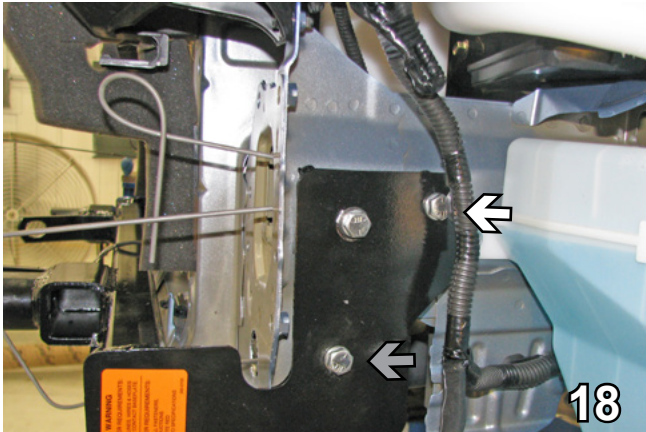

18. Start 3/8-16 x 1 1/2" bolts in top hole (white arrow) with lock washers and attach to 3/8-16 nut plates. Insert 3/8-16 x 2" bolts in the bottom hole (gray arrow) attach to a spacer and 3/8-16 nut plate inserted into the end of the frame rail. Use Loctite on all bolts before tightening.
19. Attach the permanent baseplate safety cables to the provided convenience link on the baseplate (gray arrow). The photo above shows the recommended installation of the cables to frame of vehicle (white arrow). Additional options may interfere with suggested mounting; in this case secure the cables to a solid piece of the frame as described in the instructions included with the permanent baseplate safety cables. Be sure the safety cables do not rub against any hoses or moving parts. Do this to both sides of the vehicle.

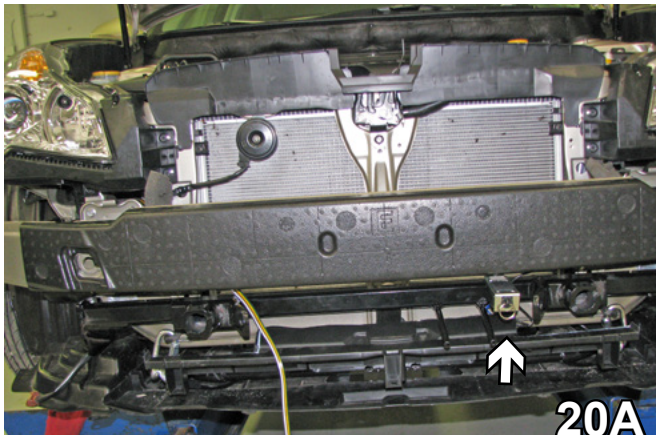

**OPTIONAL:**

20. **2010 Models:** On the driver side, align the breakaway to the bottom of the metal bumper just outside of the electrical plug. Mark and drill a hole on the bottom of the bumper. Install the breakaway with 1/4-20 hex bolt and 1/4-20 hex nut. (20A)
20. **2011 Models:** On the passenger side, place the breakaway bracket on the bottom of the bumper close to the center of the baseplate. Mark and drill a hole on the bottom of the bumper. Install the breakaway bracket to the bumper and attach the breakaway to the bracket with 1/4-20 hex bolt and 1/4-20 hex nut. (20B)
20. **2012 Models:** On the passenger side, place the breakaway bracket on the bottom of the bumper close to the center of the baseplate. Install the breakaway bracket with a 10-16 x 1" self-drilling screw and attach the breakaway to the bracket with 1/4-20 hex bolt and 1/4-20 hex nut. **NOTE: Only baseplates manufactured November 1, 2011 and later will include the 10-16 x 1" self-drilling screw. Should you require this hardware for baseplate installation on a 2012 Subaru Outback, please contact Blue Ox Manufacturing Customer Care Department at (402) 385-3051.**
20. **2013 Models:** On the driver side, place the breakaway bracket on the bottom of the bumper close to the center of the baseplate. Install the breakaway bracket with a 10-16 x 1" self-drilling screw and attach the breakaway to the bracket with 1/4-20 hex bolt and 1/4-20 hex nut



BX3617  
2011-14 Subaru Outback  
Installation Instructions

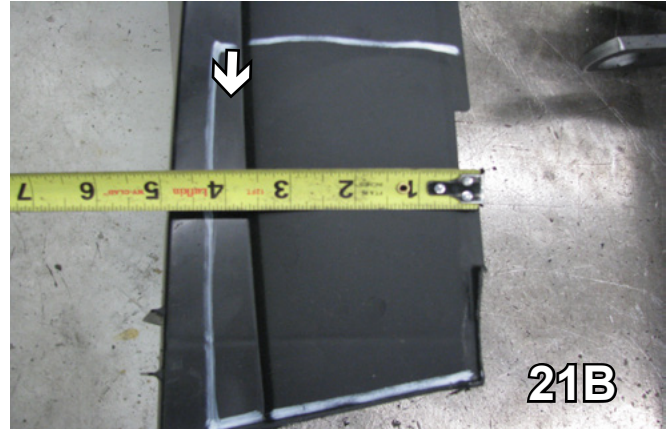
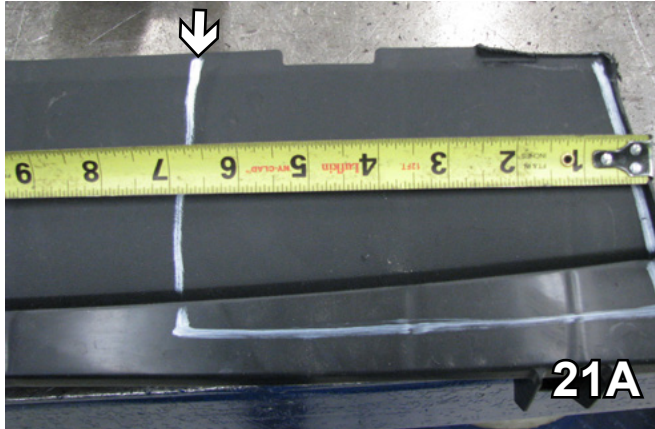

21. **2010 Models:** Using the utility knife, trim both ends completely off of the plastic cover. Then trim starting 6 1/2" from the edge straight down 4 1/4". Do this on both sides.
22. Install the tow bar and safety cables according to the instructions provided in their packages. When demonstrating this to the customer, be sure to include all the contents and packages.

Do **NOT** substitute other devices if the tow bar pins and clips are misplaced.

**DEALER or INSTALLER:**  
Be certain the user receives the  
instruction sheets for their products.

Be sure that **ALL** electrical connections  
are plugged in properly and functioning  
**BEFORE** installing the fascia.

**If the baseplate is in an accident, it must be replaced. DO NOT use it again! An accident can cause unseen damage and using it again could result in more damage or serious injury. DO NOT use the baseplate if it is damaged or missing parts.**

### CUSTOMER SERVICE COMMITMENT

Blue Ox® is committed to providing you with exceptional customer care throughout your lifetime with our products. Our team is here to assist you with any questions you may have regarding the performance of your product. Simply call (402) 385-3051 and you can speak with our customer care team.

Additionally, please visit our website to see which rallies our Destination America team will be attending. For a nominal fee, our service technician will service your towing system to ensure it's in proper working condition. Also, as a commitment to our customers, should you visit our factory, you can stay at our full service Blue Ox® campground at no charge along with enjoying a factory tour.

Again, thank you for being our customer and for the confidence you have shown in the performance of our products. It is because of customers like you we enjoy the success we have today.

© 2013 Blue Ox  
One Mill Road, Industrial Park  
Pender, Nebraska 68047  
Phone: (402) 385-3051  
Fax: (402) 385-3360  
www.blueox.com