



BX3735 Installation Instructions
'99-2002 Toyota Solara SLE, V-6

1998-'99 Toyota Avalon

Serial No.

Avalon: Rock guard needs to be removed. Front fascia lower opening has two sections that need to be removed. Existing holes are to be drilled out. The attachment tabs are 24 inches center to center. Vehicle factory tie down brackets will be utilized for the safety cable.

Solara: The front fascia is removed for baseplate installation. Holes need to be drilled. Temperature sensor will be relocated. The attachment tabs are 24 inches center to center. Vehicle factory tie down brackets will be utilized for the safety cable.

Both the Avalon and the Solara can be fitted with the BX8869 (see photo on page 2).



1. *Remove phillips screw from blinker assembly pull forward, unplug, and set aside.*



2. *Just under blinker assembly is one push pin to remove.*



3. *Using the 10MM socket remove the metric bolts from the top side of grill.*



4. *Remove one metric nut with 8MM socket just behind head light assembly, both sides.*



5. *Remove metric bolts from the inside of fascia end.*



6. *Remove two metric bolts from the inside front wheel well both sides and the six metric bolt from the underside of the fascia using the 10MM socket.*



Strong As An Ox™



7. Remove two push pins and using the 10MM socket remove six from under fascia. Unplug all electrical connections, pull fascia forward, and set aside.



9. **For the Solara**, use a hammer to drive the stud into the frame and drill out holes with the 13/32" drill bit. Insert items 3 and 5 into 1" hole to align with stud holes. **For the Solara and Avalon:** Hold base plate into position and tighten items 5, 6, and 7 to item 3 (refer to drawing on last page). **Be sure and use loctite on all bolts before tightening.**



8. Drill 1" hole on the outside of frame ends (refer to photo for location).



10. Using the base plate as a template drill the holes on the bottom side of the metal bumper. Insert item 2 into bumper end to align with holes and tighten items 4 and 6. **Be sure and use loctite on all bolts before tightening.** Center item 9 and use the bracket as a template, drill two holes with 5/32" drill bit, and install with item 8 (refer to drawing on last page).

11. Reinstall fascia, blinker assembly, and plug in all electrical connections. Trimming of the grill is needed for the 1998 Avalon.

12. The dimensional variations between otherwise identical cars can be considerable. While the location and size of the holes in the baseplate were designed to allow for easy installation, it may be necessary to file a hole slightly to allow a bolt to clear.

13. Install the tow bar and safety cables according to the instructions included in their packages.

14. Do **not** substitute other devices if the tow bar pin and clip are lost.

15. **DEALER OR INSTALLER: BE CERTAIN THE USER RECEIVES THE INSTRUCTION SHEET.**



Location for the BX8869.



Tools Required

10MM Socket
9/16" Socket
1" Hole Saw

Loctite Blue
Vise Grips

17/32" Drill Bit
5/32" Drill Bit

Parts List

Ref. No.	Qty.	Part No.	Description
1	1	61-5230	Weldment, Base Plate, BX3735
2	2	61-5231	Weldment, 3/8-16, Nut Plate
3	4	61-5285	Weldment, 3/8-16 x 1 1/2, with Wire
4	2	201-0368	3/8-16 x 1 1/4 Hex Bolt, Grd. 5, ZP
5	8	203-0003	3/8 Flat Washer, ZP
6	6	203-0010	3/8 Lock Washer, ZP
7	4	202-0003	3/8-16 Hex Nut, ZP
8	2	201-0654	#10-16, Self Tapping Screw
9	1	61-5488	Weldment, Electrical Bracket
10	2	201-0553	1/4-20 x 1/2 Hx. Wshd, Type F Screw
11	2	202-0047	#10-32 Hex Nut
12	2	203-0054	#10 Lock Washer
13	2	201-0192	#10-32 x 1/2 Slot, Rd. Hd. Screw
14	2	101-5822	Adapter, 4 Way Connector
	2	226-0046	Baseplate Safety Cable, 36" CL III (Not Shown)
	2	229-0359	Quicklink, 3/8, ZP (Not Shown)



Solara 2001

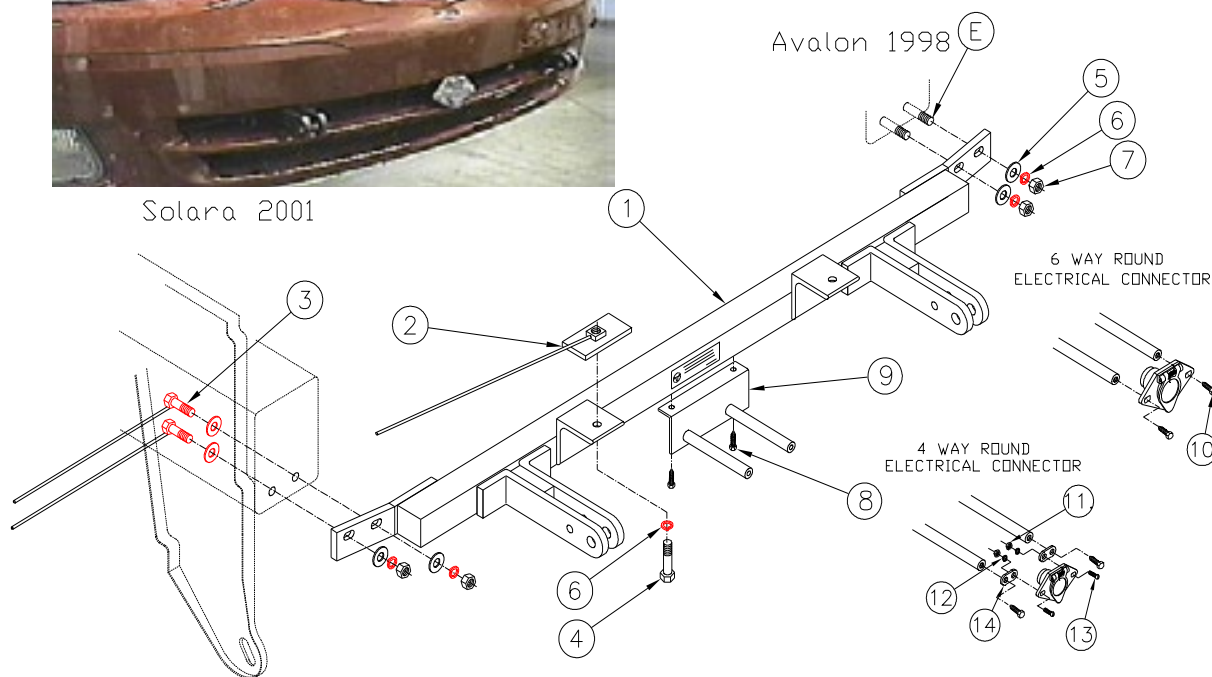

IMPORTANT: Use only genuine factory replacement parts on your Base Plate. Do not substitute homemade or nontypical parts. If a bolt is lost or in need of replacement, for your safety and the preservation of your Base Plate, be sure to use a replacement bolt of the same grade (Usually Grade 5, refer to parts list). Repair parts may be ordered through your nearest **Blue Ox** dealer or distributor.