



BX3741 2000-03 Toyota Echo Installation Instructions

Serial No.

The front bumper fascia and metal bumper are removed for baseplate installation. Holes need to be drilled and the plastic shrouds for the radiator and grill need to be trimmed.



Figure 1



Figure 2



Figure 3



Figure 4

1. Open the hood and remove the push pins and snaps which hold the top grill above the bumper fascia, figure 1 and 2. Set the small grill piece off to the side.

2. Remove the push pins from the top of the plastic fascia (same as ones in step 1) and the Hex bolts from bottom of the plastic fascia, figure 3.

3. Hold the fender well molding out just in front of the tire and remove the push pin and Hex bolt. (each side). Remove bumper fascia.

4. After plastic fascia is off remove the four bolts (two on each side) holding metal, figure 4. Remove the horn wire fastened to the bumper and pull bumper off (driver side).

5. Remove the nuts holding the bumper brackets and set brackets aside, figure 5.

6. Remove drivers side towing bracket, figure 6.

7. On passenger's side, remove the lower bolt to the washer fluid reservoir so the baseplate can be placed properly on frame, figure 7.

8. Notice one inch hole on front of frame (passenger side), drill similar hole for the drivers side, figure 8.

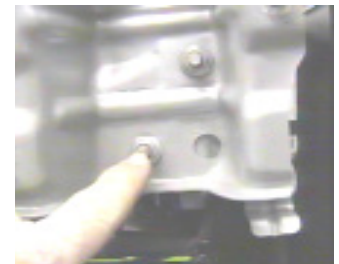

Figure 5

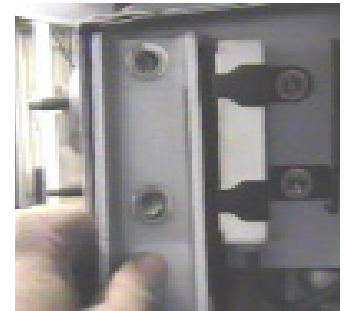

Figure 6



Figure 7



Figure 8

BX3741
2000-03 Toyota Echo
Installation Instructions

9. Remove the plastic pieces on each side of the radiator, figure 12.



Figure 9



Figure 10



Figure 11

10. When placing the baseplate on the frame the top of the side plates should go in first with the baseplate at an angle to avoid hitting the tubing, figure 9. Be sure to have the side plate on the passenger side sandwiched between the washer reservoir and the frame, figure 10. Reuse the bolts from the tow bracket on driver side plate. Use the 6MM bolt from the kit (replacing reservoir bolt) to help hold baseplate on the passenger side. Drill remaining holes and use the hardware according to the drawing on the last page. Use the baseplate as a template to drill the remaining holes (3/8") for the inside braces, figure 11.

11. The wire nuts can be inserted into the frame through the large holes on front of the frame, figure 8. Apply Loctite to each nut.

12. Trim the plastic pieces which were on each side of the radiator to fit around the baseplate and replace the horn wire, figure 12.

13. Hold the bumper fascia up to its original position and mark area needed to be trimmed on the plastic grill to allow the attachment tabs to extend through, figure 13. Replace bumper fascia and any electrical wiring disconnected during the installation. **DEALER OR INSTALLER: BE CERTAIN THE USER RECEIVES THE INSTRUCTION SHEET.**

14. The dimensional variations between otherwise identical cars can be considerable. While the location and size of the holes in the baseplate were designed to allow for easy installation, it may be necessary to file a hole slightly to allow a bolt to clear.



Figure 12



Figure 13

Tools Required

12MM Socket
14MM Socket

9/16" Socket
3/4" Socket

Loctite Blue
7/16" Socket

1" Hole Saw
Utility Knife

BX3741

2000-03 Toyota Echo

Installation Instructions

Parts List

Ref. No.	Qty.	Part No.	Description
1	1	61-5498	Weldment, Baseplate, BX3741
2	9	203-0010	3/8 Lock Washer, ZP
3	9	203-0003	3/8 Flat Washer, ZP
4	9	201-0368	3/8-16 x 1 1/4 Hex Bolt, Grade 5
5	1	201-0655	6MM-1 x 30 MM Hex Bolt, Grade 8.8
6	7	61-4978	3/8 Whiz Nut with Wire
7	2	201-0553	1/4-20 x 1/2 Self Tapping Hex Nut
8	2	202-0047	#10-32 Hex Nut
9	2	203-0054	#10 Lock washer
10	2	201-0192	#10-32 x 1/2 Slot, Rd. Hd Screw
11	2	101-5822	Adapter, 4 way Connector
12	2	202-0003	Hex Nut, ZP
	2		Existing Bolts, Tie Down Brackets

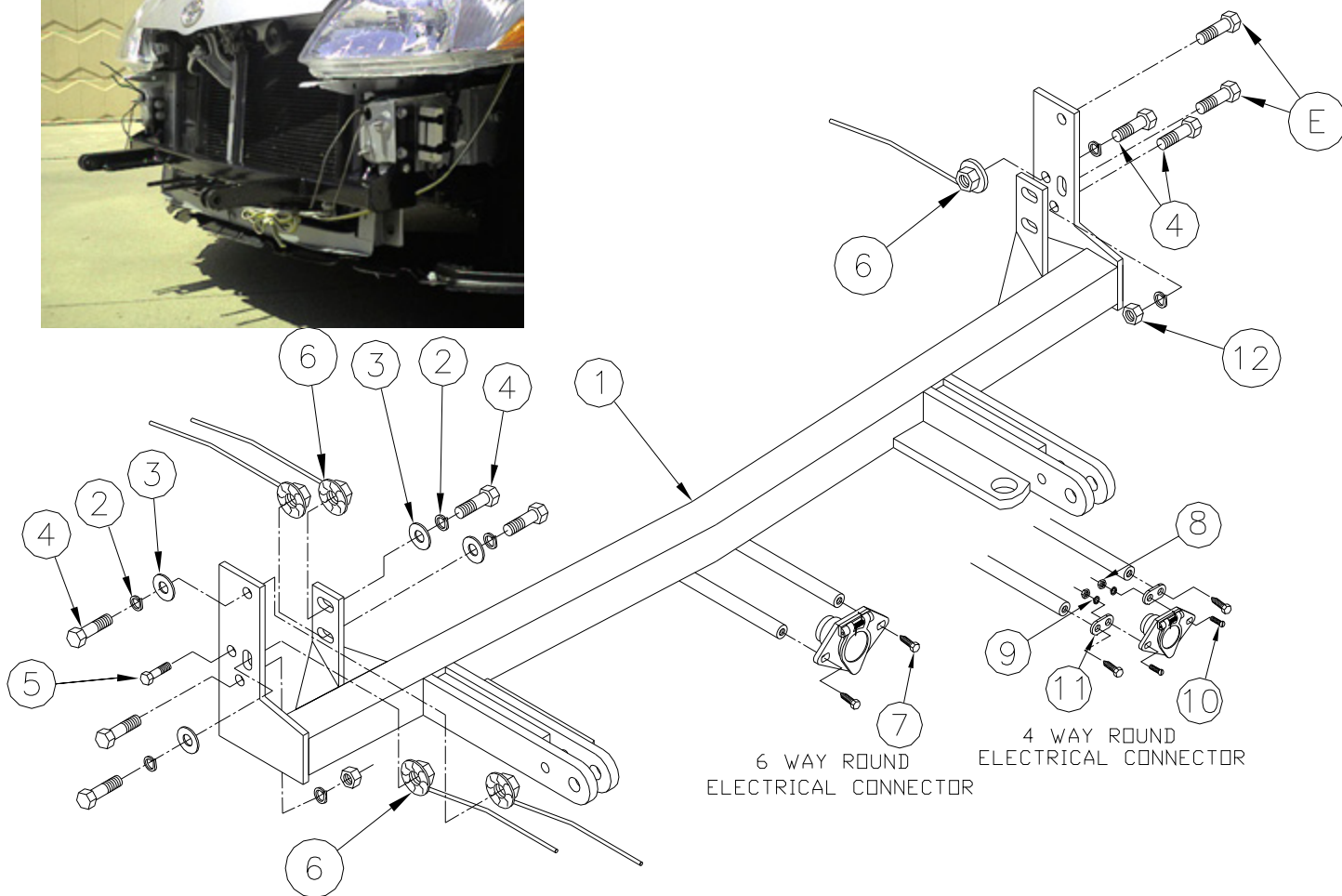

IMPORTANT: Use only genuine factory replacement parts on your Base Plate. Do not substitute homemade or nontypical parts. If a bolt is lost or in need of replacement, for your safety and the preservation of your Base Plate, be sure to use a replacement bolt of the same grade (Usually Grade 5, refer to parts list). Repair parts may be ordered through your nearest **Blue Ox** dealer or distributor.