



Strong As An Ox™

## BX3755 Installation Instructions 2002-04 Toyota Camry LE

Serial No.

The front fascia and metal bumper are removed for baseplate installation. Holes need to be drilled. The BX8869 is available for the vehicle. Attachment Tabs are 20 inches center to center and a height of 13 1/2 inches.



1. Remove two metric bolts with the 10MM socket, both sides, and one push pin on top side of fascia.



2. Using the 10MM socket, remove seven metric bolts on the bottom side of fascia.



3. Just forward of front tires, on fascia's corner, remove one metric bolt with the 10MM socket, both sides.



4. Just outside of head light, pull fascia corners to the side and forward to relieve fascia retainer clip, both sides, and set fascia aside.



5. Disconnect wire harness from back and top side of metal bumper. Pull molded styrofoam forward and set aside.



6. Using the 14MM socket, remove 6 metric bolts from the metal bumper, pull forward and set aside.



Strong As An Ox™

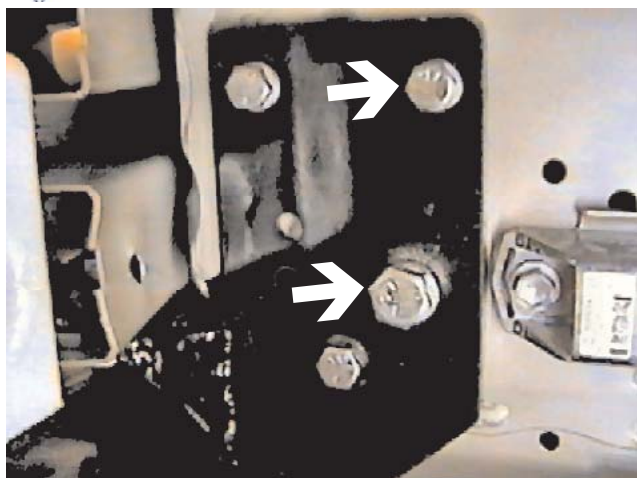

7. Align back holes on baseplate with existing holes on frame and clamp to frame with the vise grips. **Some models may require these holes to be drilled out.** Then insert 1/2" whiz nut into frame end to align with existing lower back hole, fasten 1/2" hex bolt and lock washer, both sides. Insert 3/8" nut plate into frame end to align with the upper existing hole, fasten 3/8" hex bolt and lock washer, both sides. While maintaining a level position for the attachment tabs, tighten all bolts. Using the baseplate as a template drill remaining holes into frame with the 13/32" drill bit. Insert small 3/8" nut plate into frame end to align with the two front drilled holes, tighten 3/8" hex bolt and lock washer, both sides. Install 3/8" bolt into lower drilled hole, tighten 3/8" hex nut and lock washer, both sides. **Be sure and use loctite on all bolts before tightening. Tighten all bolts according to the Torque Chart in the General Instructions sheet.**

8. Reinstall metal bumper and tighten all bolts. Using the baseplate as a template drill the holes on the bottom side of the metal bumper with the 13/32" drill bit. Insert large 3/8" nut plate into end of metal bumper to align with drilled hole, fasten 3/8" hex bolt and lock washer, both sides. **Be sure to use loctite on all bolts before tightening. Tighten all bolts according to Torque Chart in the General Instruction sheet.**

9. Reinstall wiring harness on metal bumper, molded styrofoam and fascia. Be sure all electrical connections are properly secured.
10. The dimensional variations between otherwise identical cars can be considerable. While the location and size of the holes in the baseplate were designed to allow for easy installation, it may be necessary to file a hole slightly to allow a bolt to clear.
11. Install the tow bar and safety cables according to the instructions included in their packages.
12. Do **not** substitute other devices if the tow bar pin and clip are lost.
13. **DEALER OR INSTALLER: BE CERTAIN THE USER RECEIVES THE INSTRUCTION SHEET.**



Strong As An Ox™

## Tools Required

10MM Socket  
14MM Socket  
Vise Grips

9/16" Socket  
3/4" Socket  
Loctite Red

13/32" Drill Bit  
17/32" Drill Bit

## Parts List

Ref. No.	Qty.	Part No.	Description
1	1	61-5983	Weldment, Base Plate, BX3755
2	2	61-5556	Weldment, 3/8-16, Nut Plate, with Wire
3	6	61-5208	Weldment, 3/8-16, Nut Plate, with Wire
4	2	61-4029	1/2-13, Whiz Nut, with Wire
5	2	201-0011	1/2-13 x 1 1/4 Hex Bolt, Grd. 5, ZP
6	2	203-0012	1/2 Lock Washer, ZP
7	8	201-0368	3/8-16 x 1 1/4 Hex Bolt, Grd. 5, ZP
8	8	203-0010	3/8 Lock Washer, ZP
9	2	202-0003	3/8-16 Hex Nut
10	2	201-0553	1/4-20 x 1/2 Hx. Wshd, Type F Screw
11	2	201-0192	#10-32 x 1/2 Slot, Rd. Hd. Screw
12	2	203-0054	#10 Lock Washer
13	2	202-0047	#10-32 Hex Nut
14	2	101-5822	Adapter, 4 Way Connector
	2	226-0046	Baseplate Safety Cable, 36" CL III (Not Shown)
	2	229-0359	Quicklink, 3/8, ZP (Not Shown)

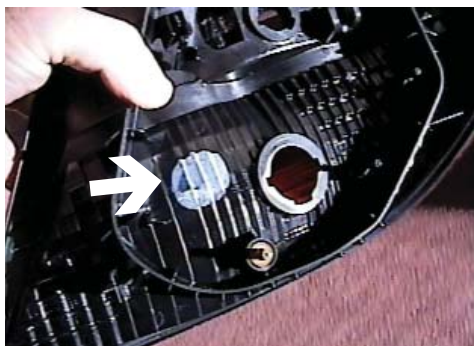

Location of drill hole for the BX8869.

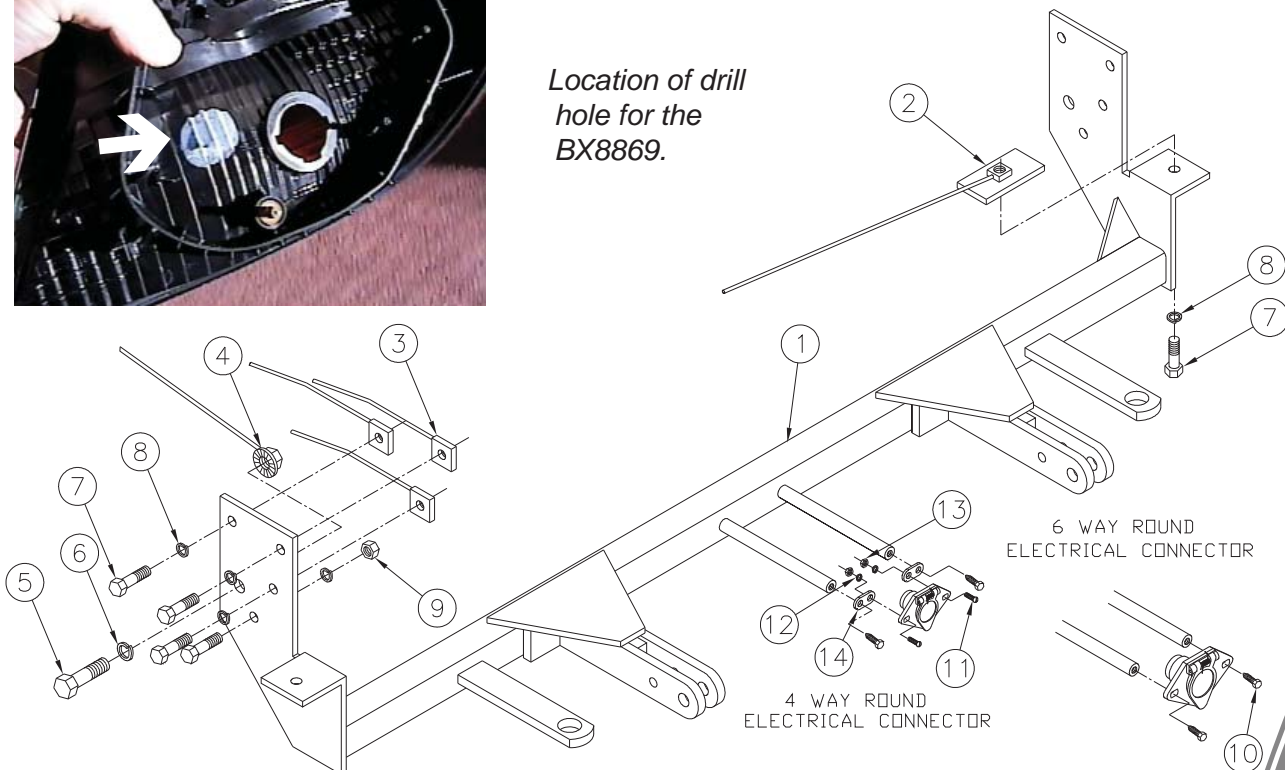

**IMPORTANT:** Use only genuine factory replacement parts on your Base Plate. Do not substitute homemade or nontypical parts. If a bolt is lost or in need of replacement, for your safety and the preservation of your Base Plate, be sure to use a replacement bolt of the same grade (Usually Grade 5, refer to parts list). Repair parts may be ordered through your nearest **Blue Ox** dealer or distributor.