



BX3760 Installation Instructions 2005 Toyota Scion

Serial No.

Strong As An Ox™

The front fascia and air bag sensors are removed for baseplate installation. Drilling is required. Trimming of front webbing on tie down bracket is required. The BX8869 is available for the vehicle. Attachment Tabs are 24 inches center to center and a height of 13 1/2 inches.



1. Remove push pin from top edge of fascia just inside of head light assembly (white arrow), both sides. Lift top portion of hood bumper pad up to release, pull lower body up out of fascia and set aside, both sides.



2. Remove push pin from top edge of fascia just forward of hood latch.



3. Just forward of front tire is one metric bolt to remove with the 10MM socket, both sides.



4. Forward of front tires inside wheel well on fascia's upper corner is one metric bolts to remove with the 10MM socket, both sides.



5. Remove the two metric bolts just forward of the front tire, on the bottom side of fascia, using the 10MM socket, both sides.

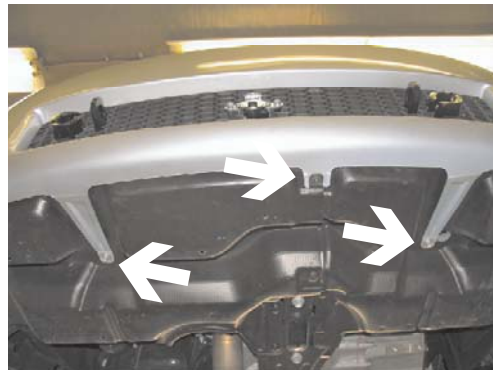

6. Remove three metric bolts from lower edge of fascia tabs with the 10MM socket. Pull fascia forward, set aside and remove styrofoam from metal bumper.



Strong As An Ox™

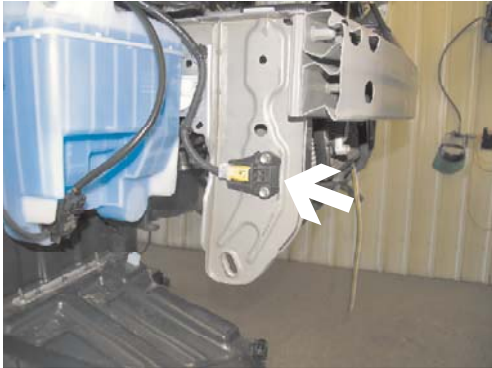

7. Using the 10MM socket, remove two metric bolts from air bag sensor, both sides and carefully tie up out of the way.



8. Measure 10 1/2" down from the bottom side of upper frame webbing and mark the front webbing on tie down bracket.

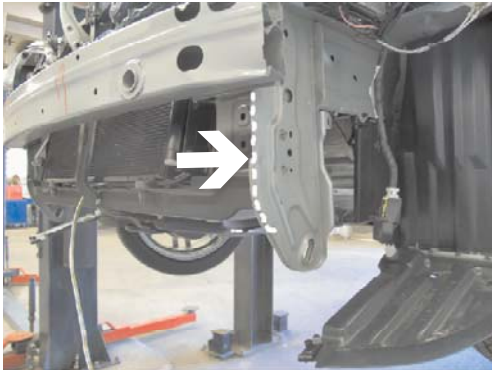

9. Using the reciprocating saw, cut and remove front webbing of tie down bracket, both sides. This will open area to allow baseplate to slide onto the outside of tie down bracket and frame.



10. Remove push pin from air dam and pull forward to release, both sides. Measure 2 1/4" and 4 3/8" down from the top of air dam, both sides.

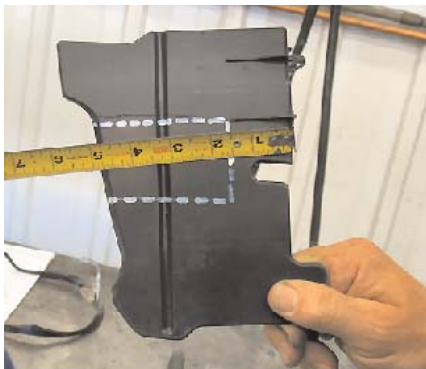

11. Measure and mark from the back edge of air dam forward 1 1/2" on both sides and cut out area with the utility knife, both sides.



12. Slide baseplate onto tie down bracket and up to align with existing holes for air bag sensors, both sides. Using the existing metric bolts for sensors, tighten metric bolts with the 10MM socket both sides. Be sure baseplate is level with vehicle. **NOTE: Baseplate is painted white to increase visibility in photo.**



Strong As An Ox™



13. Using the baseplate as a template, drill the holes into the frame and webbing with the 13/32" drill bit, both sides. **Do not drill the two back holes for the sensors.**



15. Insert spacer plate between tie down bracket and baseplate to align with the two holes on the back edge of baseplate end, both sides.

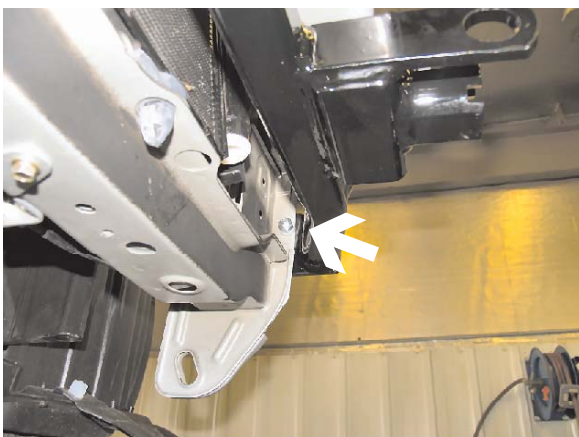

17. Insert 3/8" hex bolts into front hole in baseplate and tie down webbing, tighten the lock washer and hex nut on the back side of webbing, both sides. **Be sure to use loctite red on all bolts before tightening. Tighten all bolts according to Torque Chart in General Instruction Sheet.**



14. Insert the 3/8" nut plate into opening on top edge of frame just behind bumper bracket and align with top drilled hole. Tighten 3/8" hex bolt and lock washer, both sides. **Be sure to use loctite red on all bolts before tightening. Tighten all bolts according to Torque Chart in General Instruction Sheet.**



16. Insert 3/8" hex bolts into the two holes in baseplate, spacer plate and tie down webbing, tighten the lock washer and hex nut on the back side of webbing, both sides. **Be sure to use loctite red on all bolts before tightening. Tighten all bolts according to Torque Chart in General Instruction Sheet.**



Strong As An Ox™

- 18.** Remove the two existing metric bolts from air bag sensor used earlier in step 12. Reinstall air bag sensor using the 6MM hex bolts and lock washers with the 10MM socket, both sides.



- 19.** Hold fascia to its original position, mark and trim lower grill around receivers (for the removable tabs) and convenience links (for the safety cables) with the utility knife or hack saw blade. The electrical rods should come through the grill openings. (Electrical rods can be adjusted with a short piece of pipe if needed.)
- 20.** Reinstall fascia.
- 21.** The dimensional variations between otherwise identical cars can be considerable. While the location and size of the holes in the baseplate were designed to allow for easy installation, it may be necessary to file a hole slightly to allow a bolt to clear.
- 22.** Install the tow bar and safety cables according to the instructions included in their packages.
- 23.** Do **not** substitute other devices if the tow bar pin and clip are lost.
- 24. DEALER OR INSTALLER: BE CERTAIN THE USER RECEIVES THE INSTRUCTION SHEET.**



Strong As An Ox™

Tools Required

10MM Socket
Vise Grips
Phillips Screw Driver

9/16" Socket
Loctite Red

Utility Knife or Hack Saw blade
13/32" Drill Bit

Parts List

Ref. No.	Qty.	Part No.	Description
1	1	61-6052	Weldment, Base Plate, BX3760
2	2	61-5208	3/8" Nut Plate, with Wire
3	2	102-6560	Spacer Plate, 3/16 x 1 x 5 Inch
4	2	102-6559	Spacer Plate, 3/16 x 1 x 1 1/2 Inch
5	8	201-0368	3/8-16 x 1 1/4 Bolt, Grd. 5, ZP
6	8	203-0010	3/8 Lock Washer, ZP
7	6	202-0003	3/8-16 Hex Nut, ZP
8	4	201-0655	6MM-1.0 x 30MM Hex Bolt, Grd. 8.8, ZP
9	4	203-0009	5/16" Lock Washer, ZP
10	2	201-0553	1/4-20 x 1/2 Hx. Wshd, Type F Screw
11	2	201-0192	#10-32 x 1/2 Slot, Rd. Hd. Screw
12	2	203-0054	#10 Lock Washer
13	2	202-0047	#10-32 Hex Nut
14	2	101-5822	Adapter, 4 Way Connector
15	2	62-3468	Attachment, Assembly, SF/ SB (R)
	2	226-0046	Baseplate Safety Cable, 36" CL III (Not Shown)
	2	229-0359	Quickling, 3/8, ZP (Not Shown)
	2	290-0437	Receiver, Cap Plug (Blk) (Not Shown)

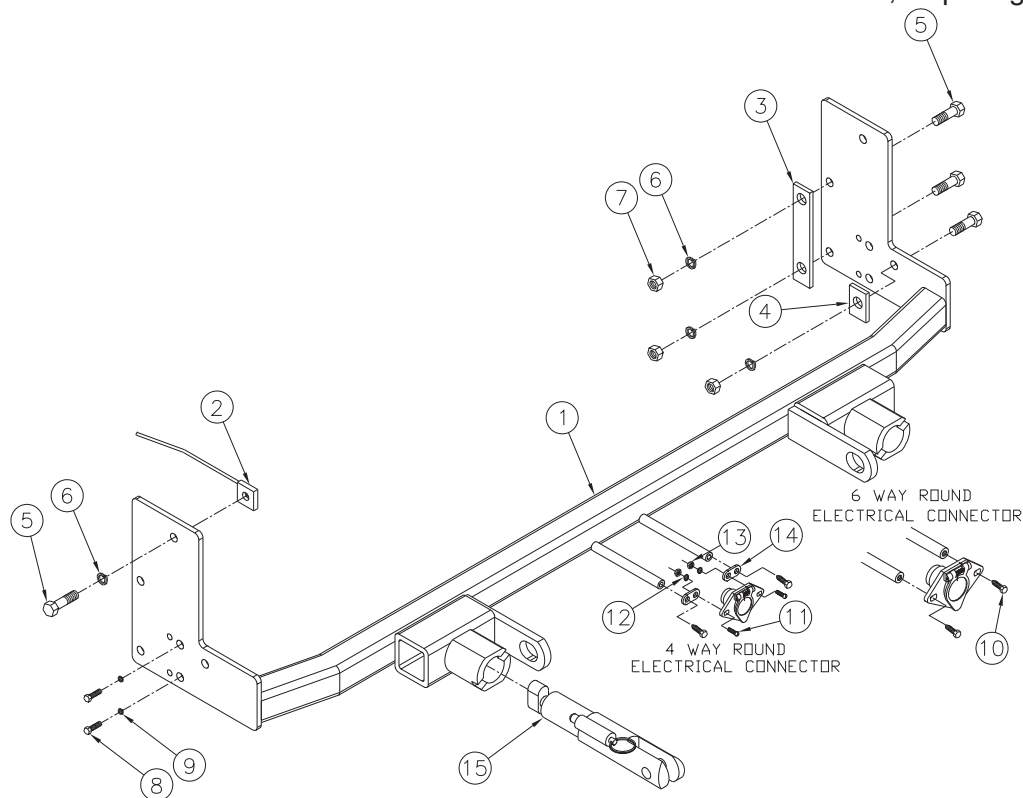

IMPORTANT: Use only genuine factory replacement parts on your Base Plate. Do not substitute homemade or nontypical parts. If a bolt is lost or in need of replacement, for your safety and the preservation of your Base Plate, be sure to use a replacement bolt of the same grade (Usually Grade 5, refer to parts list). Repair parts may be ordered through your nearest **Blue Ox** dealer or distributor.