

# BLUE OX<sup>®</sup>

## Baseplates

BX3774

### 2007-08 Toyota Solara SLE Installation Instructions

Serial Number

Please read BOTH these Installation Instructions and the General Towing Instructions before attempting to install or operate this equipment.

1. Blue Ox<sup>®</sup> towing products and accessories are intended to be installed by Blue Ox<sup>®</sup> Dealers who are familiar with our products and have the equipment and knowledge to do "fit work." When necessary, Blue Ox<sup>®</sup> Dealers can be found at [www.blueox.us](http://www.blueox.us) or by contacting our 24/7 Customer Care Department at (888) 425-5382.

Attachment Tab Height: 13.5"  
Attachment Tab Width: 18"

2. Many Blue Ox<sup>®</sup> Baseplates are designed to use existing holes and hardware to mount the baseplate to the towed vehicle. Even though bolts are there, do not assume they are adequate for baseplate mounting. Always use hardware supplied in the hardware kit or existing hardware specified in the Baseplate Towing Installation Instructions.

#### Bolt Torque Specifications

Torque in Foot-Pounds per Metric Bolts

Bolt Size	Grade 8.8	Grade 10.9
6MM	6	8
8MM	16	22
10MM	31	40
12MM	54	70
14MM	89	117

Confirm the towability and pre-towing procedures for your vehicle with the owner's manual or contact the vehicle's manufacturer for specific towing procedures. You can also contact REMCO for additional information at 1(800)228-2481.

#### Bolt Torque Specifications

Torque in Foot-Pounds per Inch Bolts

Bolt Size	Grade 5	Grade 8
1/4"	10	14
5/16"	19	29
3/8"	33	47
7/16"	54	78
1/2"	78	119
5/8"	154	230



## WARNING

Failure to read and follow these instructions could result in separation of the towed vehicle from the tow bar, causing property damage, loss of towed vehicle, personal injury or death.

# BX3774

## 2007-08 Toyota Solara SLE

### Installation Instructions

## Parts List

Ref. No.	Qty.	Part #	Description
1	1	61-6398	Weldment, Base Plate, BX3774
2	2	61-4029	Weldment, 1/2" Nut Wire
3	6	61-5208	Weldment, Nut Plate, 1/4 x 1 x 1, 3/8"
4	2	61-5556	Weldment, 3/8" Nut Plate, w 1/2" Wire
5	2	201-0011	1/2-13 x 1 1/4" Hex Bolt, Grd. 5, ZP
6	2	203-0012	1/2" Lock Washer, ZP
7	8	201-0368	3/8-16 x 1 1/4" Hex Head Bolt, Grd. 5, ZP
8	8	203-0010	3/8" Lock Washer, ZP
9	2	202-0003	3/8-16 Hex Nut, ZP
10	2	201-0553	1/4-20 x 1/2" Hex Washed Type F, ZP
11	2	201-0192	#10-32 x 1/2" Slot Round Head Screw
12	2	203-0054	#10 Lock Washer
13	2	202-0047	#10-32 Hex Nut
14	2	101-5822	Adapter, 4 Way Connector
15	2	62-3468	Attachment, Assembly, SF/SB, 1 Hole
	2	290-0437	Cap Plug, Black (not shown)
	2	229-0359	Quicklink, 3/8", ZP (not shown)
	2	226-0046	Baseplate Safety Cable, 36" Class III (not shown)

## Tools Required

Loctite® RED	9/16" Socket
10MM Socket	13/32" Drill Bit
Reciprocating Saw	Tape Measure
Utility Knife	Phillips Screwdriver
Flat Screwdriver	

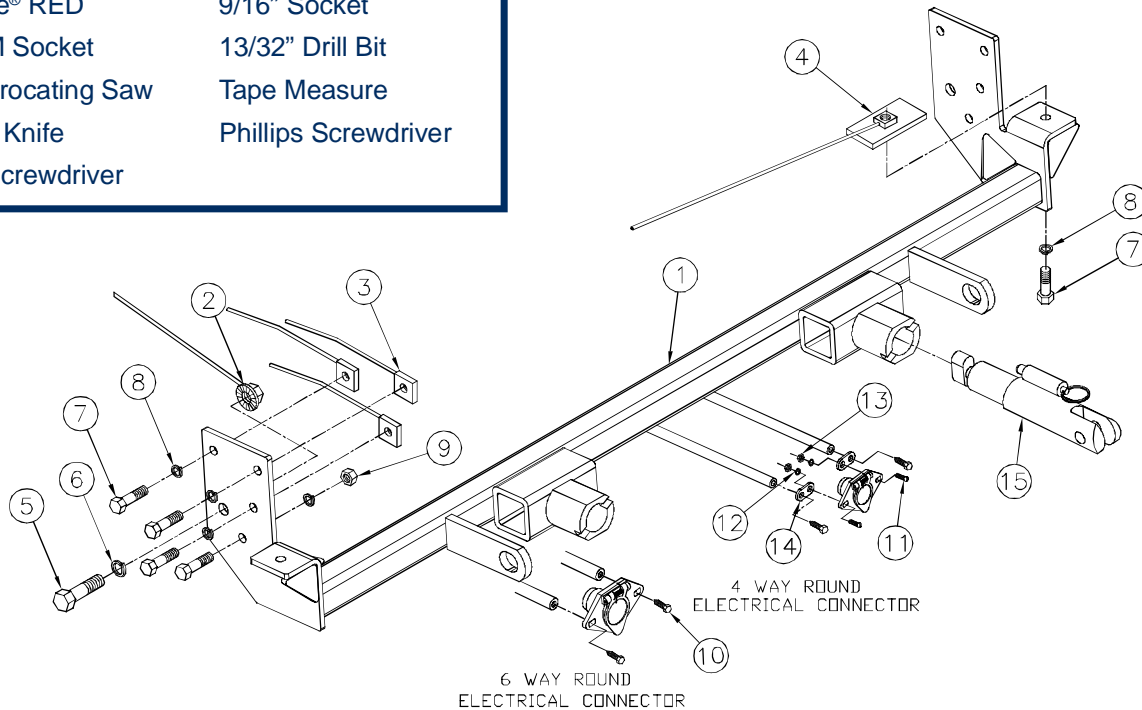

### Important:

Use only genuine factory replacement parts on your baseplate. Do **NOT** substitute homemade or non-typical parts. If a bolt is lost or in need of replacement, for your safety and the preservation of your baseplate, be sure to use a replacement bolt of the same grade (In most cases it will be Grade 5, please reference the parts list above). Replacement parts may be ordered through your nearest Blue Ox® Dealer or Distributor.

# 2007-08 Toyota Solara SLE

## Installation Instructions

### Vehicle Weight:

The weight of this vehicle is near the Class III, 5,000 lb. rating limitations. Some models, depending on options, may well exceed this 5,000 lb. rating. Be sure to confirm the weight of your individual vehicle before towing. As of 1999, the Aventa® II is now 10,000 lbs. and either the Aventa® II or the Aventa® LX tow bar must be used for these applications.

**Tow Bar Adapters are NOT to be used with vehicles weighing over 5,000 lbs.**

**Installation Notes:** The fascia metal bumper and air baffle are removed and reinstalled during installation of the baseplate. Drilling is required. Trimming of the fascia is required.

The dimensional variations between otherwise identical vehicles can be considerable. While the baseplate was designed for easy installation, it may be necessary to tailor the baseplate slightly to compensate for auto manufacturer's tolerances. These minor adjustments may include filing a hole slightly, bending electrical rods and/ or bending end plates.

The BX8869 Bulb and Socket Wiring Kit is recommended for this vehicle.

### Installation Instructions:

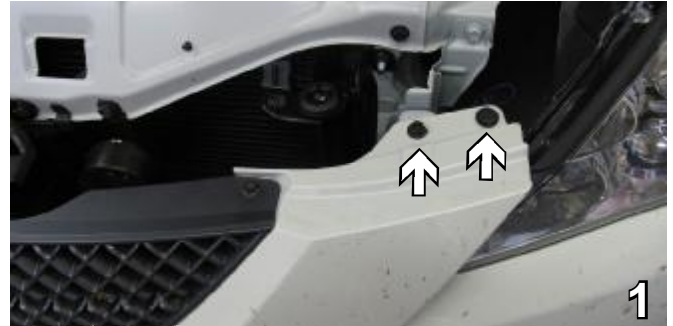

1. Using a Phillips flat screwdriver, remove one plastic push pin and one metric from both sides. There is also one push pin from the center by the hood latch to remove. Set push pins and bolts aside to be reinstalled later.



2. Using a Phillips flat screw driver turn the push pin horizontally then remove.

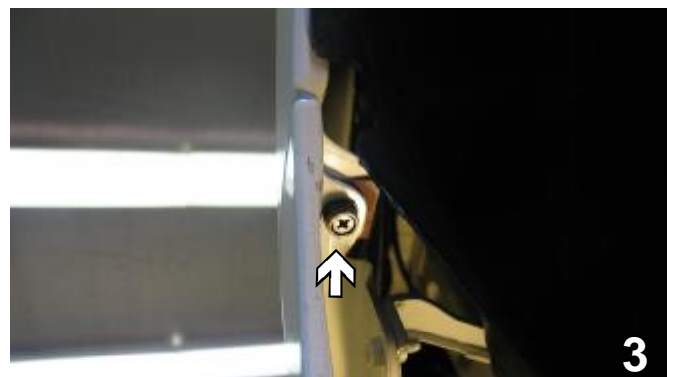

3. Using a 10MM socket, remove one metric bolt inside front wheel well on fascia's upper corner. Do this on both sides of vehicle. Set bolts aside to be reinstalled later.

# BX3774

## 2007-08 Toyota Solara SLE

### Installation Instructions



4. Using 10MM socket, remove seven metric bolts underneath the fascia.

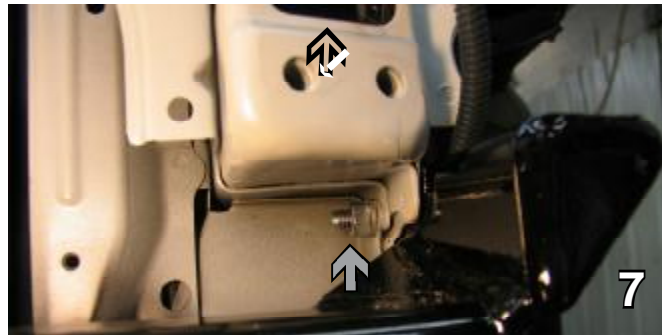

7. Install nut plates through the top, and install one from the bottom (gray arrow). Reinstall metal bumper. Using the base plate as a template, drill a hole into the bottom of the metal bumper with the 13/32" drill bit, on both sides. Insert the 3/8-16 nut plate with the 12 inch wire into the opening on the front of bumper to align with drilled hole, tighten the 3/8-16 hex bolt and lock washer, on both sides.



5. Pull the styrofoam off, unclip the four clips across the top of the metal bumper. Remove the bolts with a 14MM socket from both sides. Set aside for later reinstallation.

8. Reinstall molded styrofoam on the front of metal bumper and fascia.

9. The dimensional variations between otherwise identical cars can be considerable. While the base plate was designed for easy installation, it may be necessary to tailor the baseplate slightly to compensate for auto manufacturers' tolerances. These minor adjustments may include filing a hole slightly, bending electrical rods, adding shims and/ or bending endplates.

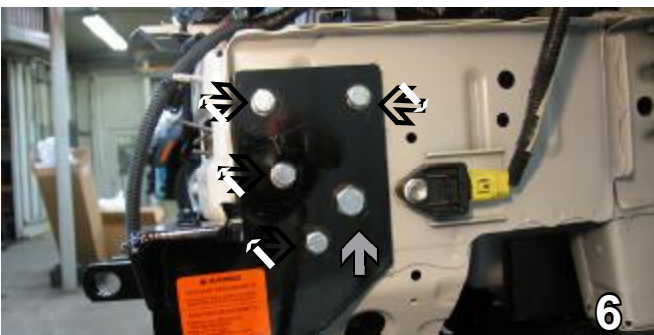

6. Using the baseplate as a template, drill the needed holes with a 3/8" drill bit. The larger bolt is the existing hole (gray arrow). Do this to both sides.

**Using a good quality paint, spray cut edges of frame to prevent rusting.**

**BE SURE TO USE LOCTITE® RED ON ALL BOLTS BEFORE TIGHTENING. TIGHTEN ALL BOLTS ACCORDING TO THE TORQUE CHART ON THE FRONT PAGE OF THESE INSTRUCTIONS OR ON PAGE 3 OF THE BASEPLATE TOWING GENERAL INSTRUCTIONS.**

**Be sure that ALL electrical connections are plugged in properly and functioning BEFORE installing the fascia.**

**DEALER or INSTALLER:**  
**Be certain the user receives the instruction sheets for their products.**

BX3774

# 2007-08 Toyota Solara

## Installation Instructions



## Customer Service Commitment

Blue Ox® is focused on providing exemplary customer service, as observed in our mission statement and guiding principles. In accordance with this objective, Blue Ox® is proud to provide services such as repairs and general maintenance of Blue Ox® products at over 150 RV Rallies. Look for our Destination America or Blue Ox® Racing service crews at the next rally or race that you attend. If you were not present, you will find an informative, personalized note explaining any services that may have been performed to your Blue Ox® products.

Blue Ox® also offers educational seminars at rallies and through our Park and Resort teams. In addition, Blue Ox® customers visiting our factory may take advantage of the well-equipped Blue Ox® RV park at no charge to you, our valued and appreciated customer.

