

**2009-10 Pontiac Vibe
2009-13 Toyota Matrix
Installation Instructions**

Serial Number

Please read BOTH these Installation Instructions and the General Towing Instructions before attempting to install or operate this equipment.

- Blue Ox® towing products and accessories are intended to be installed by Blue Ox® Dealers who are familiar with our products and have the equipment and knowledge to do “fit work.” When necessary, Blue Ox® Dealers can be found at www.blueox.com or by contacting our Customer Care Department at (402) 385-3051.
- Many Blue Ox® Baseplates are designed to use existing holes and hardware to mount the baseplate to the towed vehicle. Even though bolts are there, do not assume they are adequate for baseplate mounting. Always use hardware supplied in the hardware kit or existing hardware specified in the Baseplate Towing Installation Instructions.

Attachment Tab Height: 14”
Attachment Tab Width: 18 1/4”

Bolt Torque Specifications
Torque in Foot-Pounds for Metric Bolts

Bolt Size	Grade 8.8	Grade 10.9
6MM	6	8
8MM	16	22
10MM	31	40
12MM	54	70
14MM	89	117

Confirm the towability and pre-towing procedures for your vehicle with the owner’s manual or contact the vehicle’s manufacturer for specific towing procedures.

Bolt Torque Specifications
Torque in Foot-Pounds for Inch Bolts

Bolt Size	Grade 5	Grade 8
1/4”	10	14
5/16”	19	29
3/8”	33	47
7/16”	54	78
1/2”	78	119
5/8”	154	230



! WARNING

Failure to read and follow these instructions could result in separation of the towed vehicle from the tow bar, causing property damage, loss of towed vehicle, personal injury or death.

BX3779

2009-10 Pontiac Vibe

2009-13 Toyota Matrix

Installation Instructions

Parts List

Ref. No.	Qty.	Part #	Description
1	1	61-6538	WELDMENT BASEPLATE, BX3779
2	6	61-5208	WLDT, NUT PLT, 1/4 X 1 X 1, 3/8" WITH 14" WIRE
3	6	201-0368	3/8-16 X 1 1/4 HEX HEAD BOLT,GRD. 5
4	6	203-0010	3/8 LOCK WASHER, ZP
5	2	201-0553	1/4-20 X 1/2 HX.WSHD.TYPE F TCS, ZP
6	2	201-0192	10-32 X 1/2 SLOT, RD. HD. SCREW
7	2	203-0054	#10 LOCK WASHER
8	2	202-0047	#10-32 HEX NUT
9	2	101-5822	ADAPTER, 4 WAY CONNECTOR
10	2	62-3469	ATT TAB ASSY, REM, SF/LB, 1 HOLE
	2	226-0046	BASEPLATE SAFETY CABLE, 36" CL III (Not Shown)
	2	229-0359	QUICKLINK, 3/8, ZP (Not Shown)
	2	290-0437	RECEIVER, CAP PLUG (BLK) (Not Shown)

Tools Required

10MM Socket
 14MM Socket
 9/16" Socket
 1 1/4" Hole Saw
 13/32" Drill Bit
 Flat Screw Driver
 Phillips Screw Driver
 Loctite Red

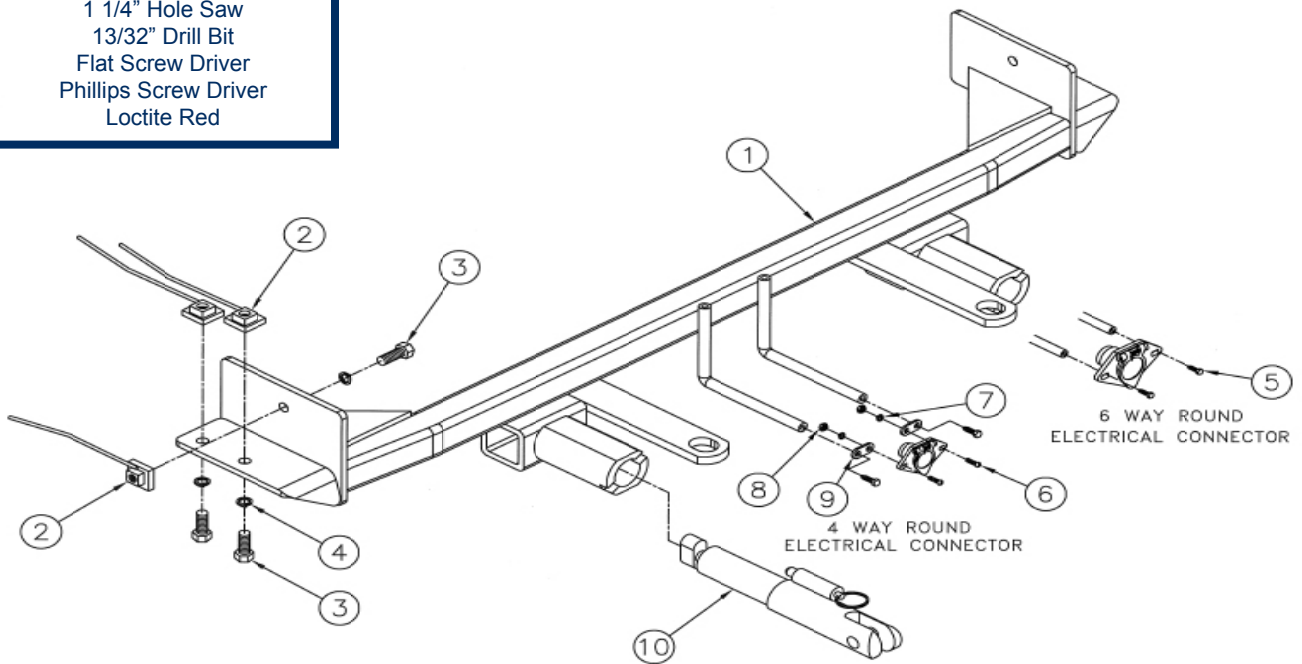

Important:

Use only genuine factory replacement parts on your baseplate. Do **NOT** substitute homemade or non-typical parts. If a bolt is lost or in need of replacement, for your safety and the preservation of your baseplate, be sure to use a replacement bolt of the same grade (In most cases it will be Grade 5, please reference the parts list above). Replacement parts may be ordered through your nearest Blue Ox® Dealer or Distributor. Failing to follow and/or altering these installation instructions in either installation or required equipment will void the manufacturer's warranty. Towing behind a non-motorized vehicle will void the warranty.

BX3779

2009-10 Pontiac Vibe

2009-13 Toyota Matrix

Installation Instructions

Vehicle Weight: Motorhome mount tow bars are recommended for use with this baseplate. Due to the design of the removable tabs, the RangeFinderII, Adventurer, Acclaim and Ambassador tow bars can not be used. Adapters, except the BX8833 and BX88151, can not be used with this baseplate.

Installation Notes: The fascia and aluminum bumper are removed and reinstalled during installation of the baseplate. Drilling is required. Trimming of the fascia is required.

The dimensional variations between otherwise identical vehicles can be considerable. While the baseplate was designed for easy installation, it may be necessary to tailor the baseplate slightly to compensate for auto manufacturer's tolerances. These minor adjustments may include filing a hole slightly, bending electrical rods or bending end plates.

The BX8869 Bulb and Socket Wiring Kit is recommended for this vehicle.



Installation Instructions:



1. Remove push pins (white arrow) from the top corner edge of the fascia. Using the Phillips screw driver, remove the Phillips screw (gray arrow), do this to both sides and set aside for later reinstallation.

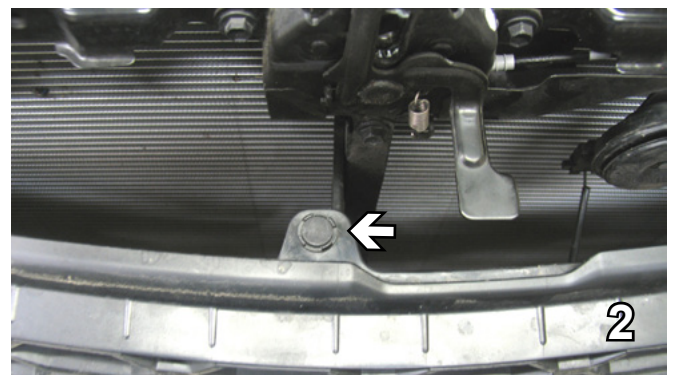

2. Remove push pin from top edge of fascia just below hood latch and set aside for reinstallation later.

Handling of some cosmetic parts when installing this product may require the use of protective covers, rags, specialty tools, etc. to prevent damage.

BX3779

2009-10 Pontiac Vibe

2009-13 Toyota Matrix

Installation Instructions



3. Just forward the front tire on the upper corner of the fascia and inside the wheel well, turn the screw 90° to remove it (white arrow). Using a Phillips screw driver, remove the upper screw (gray arrow). Do this on both sides and set aside for reinstallation later reinstallation.



4. Just forward of the front tire underneath the bumper, using a 10MM socket, remove the three metric bolts. Do this on both sides and set aside bolts for later reinstallation.

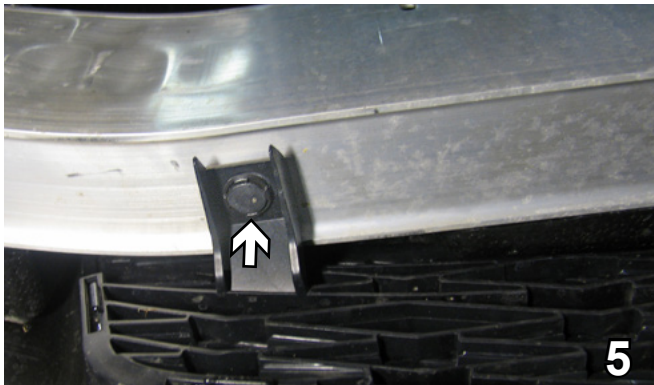

5. Behind the fascia on the bottom of the bumper, are two push pins to remove from the fascia's tabs. Remove with a flat screw driver. Pull the fascia forward on both sides and set aside carefully for later reinstallation.
7. Using a 14MM socket, remove the two bolts on each side of the bumper and take the bumper off. Set aside for later reinstallation.

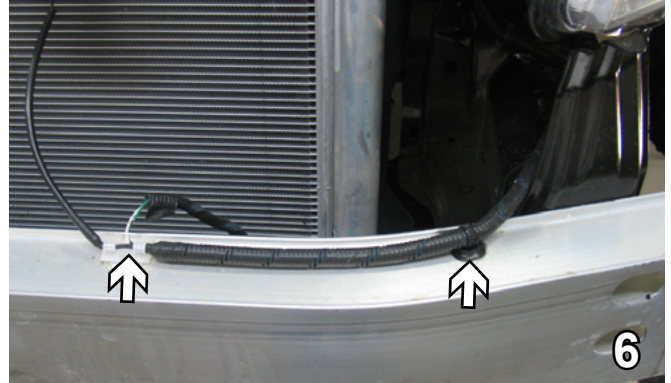

6. On the driver's side only, using a flat screw driver release the tabs from the top of the bumper and tie the wire loom up in the open area during baseplate installation.

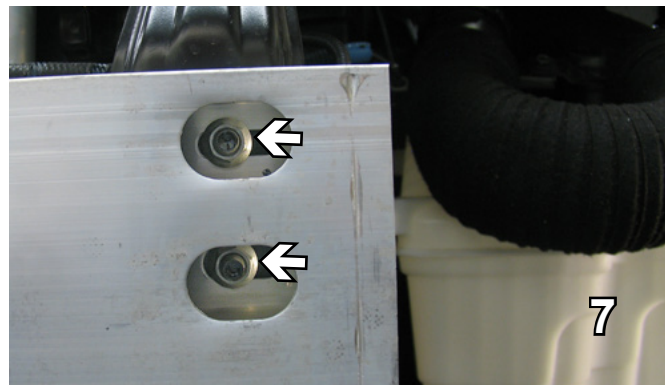

BX3779

2009-10 Pontiac Vibe

2009-13 Toyota Matrix

Installation Instructions

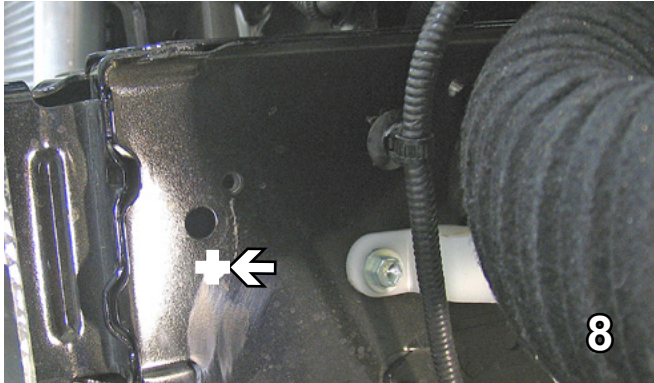

8. Drill a hole in the frame rail under but connected with the existing hole using the 1 1/4" hole saw on both sides. This hole will allow the installer to insert the nut plates inside of the frame rail.

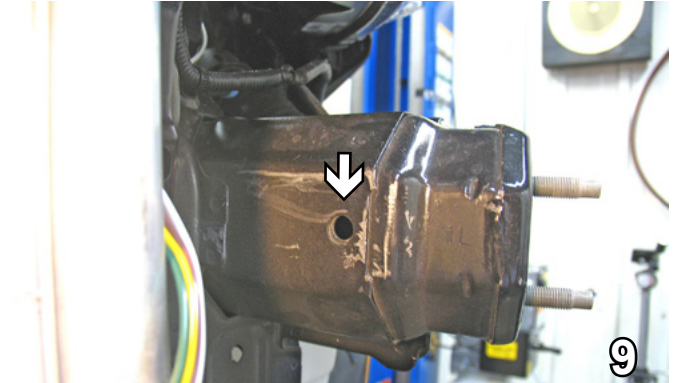

9. Slide the baseplate up between the frame rails and align with the existing hole on each side.

When using power drills be aware of the dangers of torque and drill bit length.

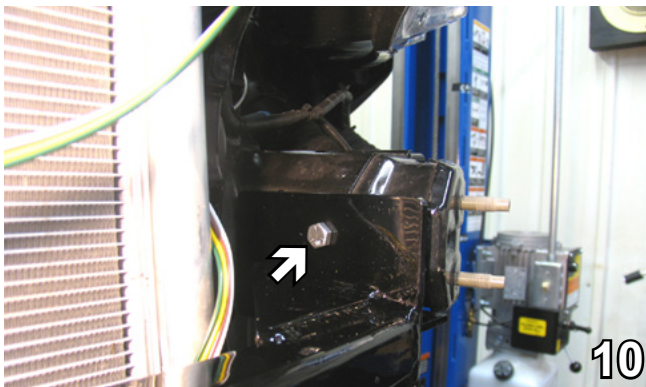

10. Insert 3/8-16 x 1 1/4" hex bolts with 3/8" lock washers attached to 3/8-16 nut plates with 14" wire inserted into the frame rail on both sides to hold the baseplate in place.

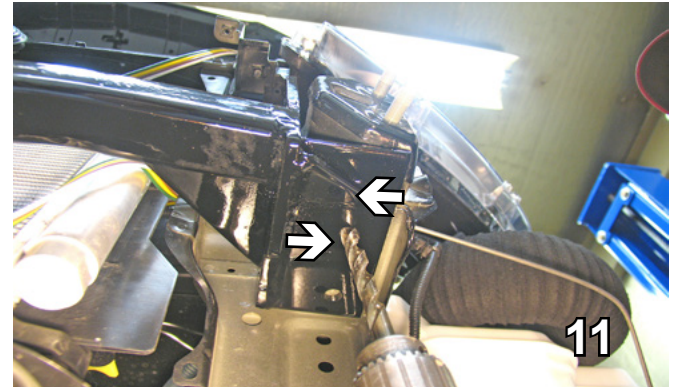

11. Using the baseplate as a template, drill both holes in the under side of the frame rail with a 13/32" drill bit. Do this on both sides.

BE SURE TO USE LOCTITE® RED ON ALL BOLTS BEFORE TIGHTENING. TIGHTEN ALL BOLTS ACCORDING TO THE TORQUE CHART ON THE FRONT PAGE OF THESE INSTRUCTIONS OR ON PAGE 3 OF THE BASEPLATE TOWING GENERAL INSTRUCTIONS.

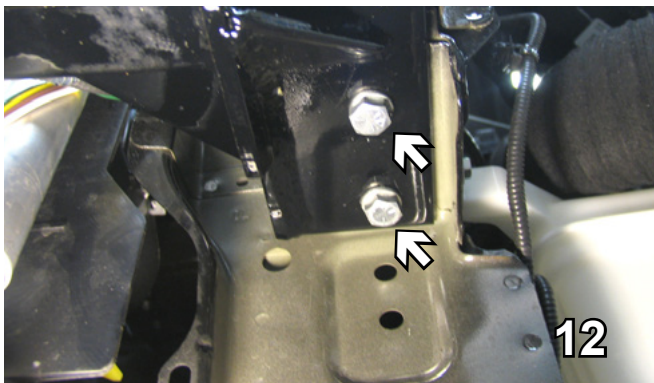

12. Insert 3/8-16 x 1 1/4" hex bolts and 3/8" lock washers with 3/8-16 nut plates with 14" wire inserted into the frame rail. Use loctite on all the bolts and tighten. Do this on both sides and the bolts inserted previously.

BX3779

2009-10 Pontiac Vibe

2009-13 Toyota Matrix

Installation Instructions

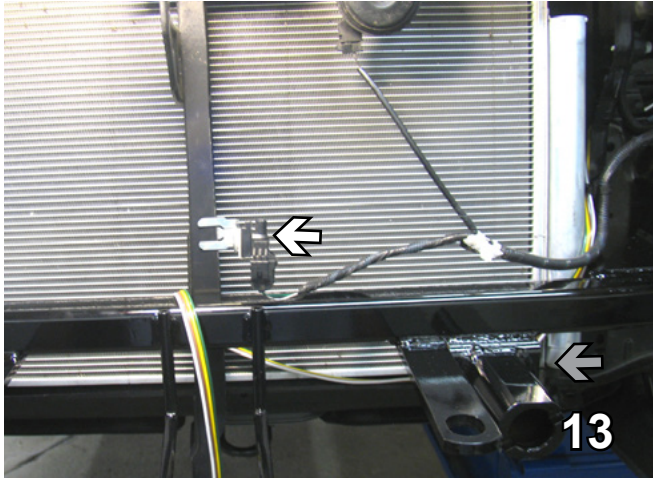

13. Move the bracket up onto the baseplate and reattach.



14. Reinstall the bumper. Be sure to reattach the wire loom to the top of the bumper.

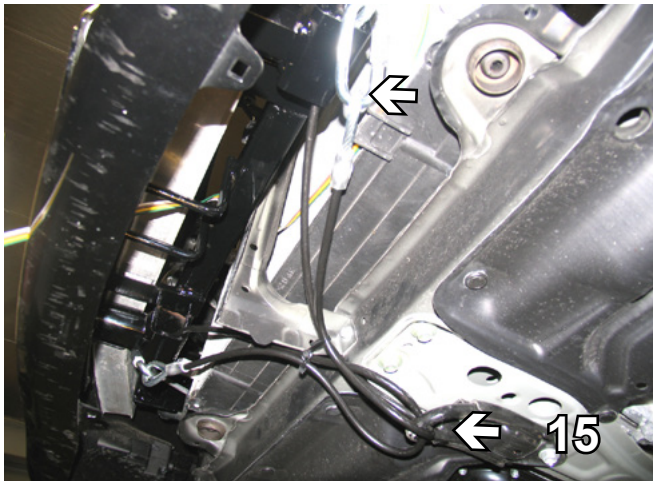

15. Attach baseplate safety cables as in above photos or as close to as possible. If you are unable to place safety cables in this location, position the cables around a solid piece of the frame.



16. Hold the fascia as close to its original position as possible, mark and trim the grill with a utility knife to allow the baseplate receivers to come through (white arrows). Reinstall the fascia. The two license plate screws on the top may have to be raised up about 1/2" (gray arrows).

Be sure that **ALL** electrical connections are plugged in properly and functioning **BEFORE** installing the fascia.

DEALER or INSTALLER:
Be certain the user receives the instruction sheets for their products.

Install the tow bar and safety cables according to the instructions provided in their packages. When demonstrating this to the customer, be sure to include all the contents and packages.

Do **NOT** substitute other devices if the tow bar pins and clips are misplaced.

BX3779

2009-10 Pontiac Vibe

2009-13 Toyota Matrix

Installation Instructions



Toyota Matrix Without Removable Tabs



Toyota Matrix With Removable Tabs



Pontiac Vibe Without Removable Tabs

If the baseplate is in an accident, it must be replaced. DO NOT use it again! An accident can cause unseen damage and using it again could result in more damage or serious injury. DO NOT use the baseplate if it is damaged or missing parts.

CUSTOMER SERVICE COMMITMENT

Blue Ox is committed to providing you with exceptional customer care throughout your lifetime with our products. Our team is here to assist you with any questions you may have regarding the performance of your product. Simply call (402) 385-3051 and you can speak with our customer care team.

Additionally, please visit our website to see which rallies our Destination America team will be attending. For a nominal fee, our service technician will service your towing system to ensure it's in proper working condition. Also, as a commitment to our customers, should you visit our factory you can stay at our full service Blue Ox campground at no charge along with enjoying a factory tour.

Again, thank you for being our customer and for the confidence you have shown in the performance of our products. It is because of customers like you we enjoy the success we have today.



Shown With Removable Tabs



© 2011 Blue Ox
One Mill Road, Industrial Park
Pender, Nebraska 68047
Phone: (402) 385-3051 • Fax: (402) 385-3360
www.blueox.com
07/27/11