



# BX88102 Reese Bracket Adapter Kit Installation Instructions

Adapts Blue Ox tow bars to Reese brackets

**Tools Required**  
3/4" Socket  
3/4" Wrench

1. Using a 3/4" socket and wrench, remove the existing 1/2"-13 bolt and 1/2"-13 jam nut from the tow bar leg. Remove the existing lug and washers from the tow bar leg. Do this on both tow bar legs.
2. Install the adapter lug onto the tow bar leg with the new washers, existing bolt and new 1/2"-13 jam nut. Tighten the bolt until the lug is tight against the washers, but can still freely move side to side. Do this on both tow bar legs.

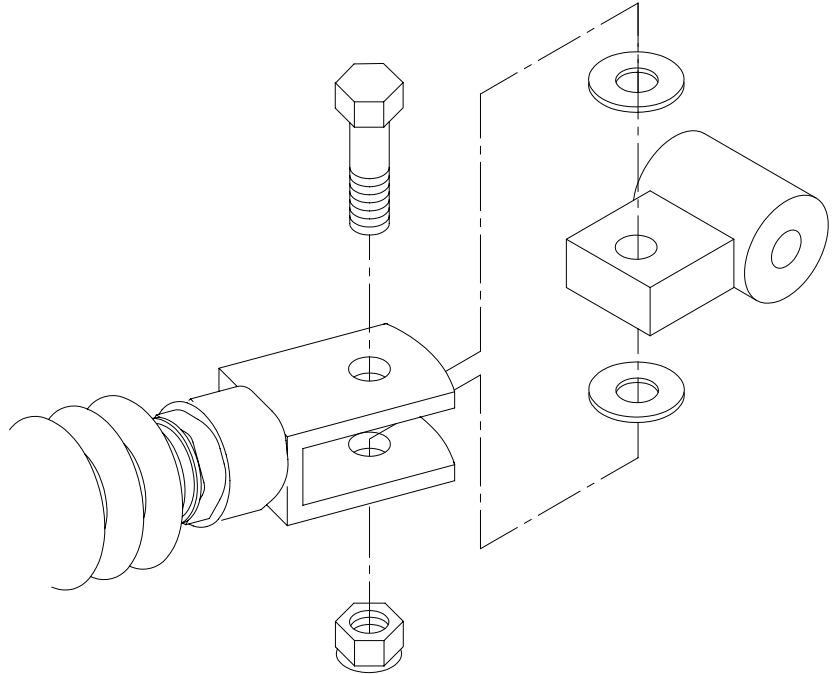

Item No.	Part No.	Description	Qty.
1.....	61-5196.....	Reese Adapter Lug.....	2
2.....	202-0143.....	1/2"-13 Essna Jam Nut.....	2
3.....	290-0381.....	Plastic Washer.....	4

## CUSTOMER SERVICE COMMITMENT

Blue Ox® is committed to providing you with exceptional customer care throughout your lifetime with our products. Our team is here to assist you with any questions you may have regarding the performance of your product. Simply call (402) 385-3051 and you can speak with our customer care team.

Additionally, please visit our website to see which rallies our Destination America team will be attending. For a nominal fee, our service technician will service your towing system to ensure it's in proper working condition. Also, as a commitment to our customers, should you visit our factory, you can stay at our full service Blue Ox® campground at no charge along with enjoying a factory tour.

Again, thank you for being our customer and for the confidence you have shown in the performance of our products. It is because of customers like you we enjoy the success we have today.

© 2013 Blue Ox  
One Mill Road, Industrial Park  
Pender, Nebraska 68047  
Phone: (402) 385-3051  
Fax: (402) 385-3360  
www.blueox.com