

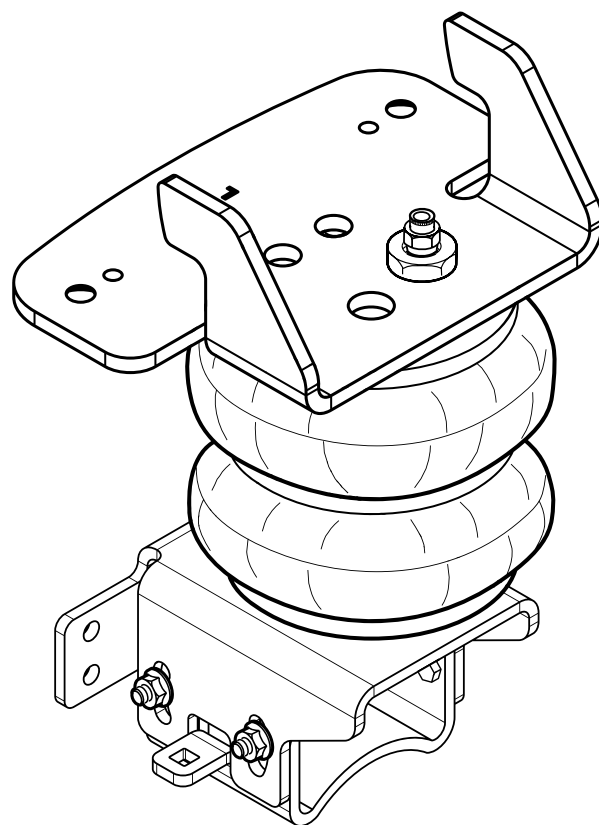

riderite.com

INSTALLATION INSTRUCTIONS



Firestone

Firestone Industrial Products

! IMPORTANT

THIS KIT ONLY FITS DUAL-REAR-WHEEL PICKUP TRUCKS. IT WILL NOT FIT SINGLE REAR-WHEEL TRUCKS.

FITS: • 2017 and up Ford F350 4WD with Dual Rear Wheels • 2017 and up Ford F450 4WD Pickup (not Cab and Chassis)

PLEASE DON'T HURT YOURSELF, YOUR KIT OR YOUR VEHICLE. TAKE A MINUTE TO READ THIS IMPORTANT INFORMATION.

DO NOT INSTALL IF THE TRUCK HAS BEEN LIFTED AND THE STOCK JOUNCE BUMPER SPACERS ARE NOT ON THE VEHICLE. *This kit is to be used on a **pickup truck only**, and **DOES NOT INCREASE YOUR VEHICLE'S MAXIMUM LOAD.***

SAFE INSTALLATION

Please take all safety precautions during installation. A hydraulic jack can fail, and if that happens, you can be seriously hurt, or worse, if you are relying on it to hold up the vehicle. If you use a hydraulic jack, secure jack stands in the appropriate locations and chock any tires still touching the ground.

Wear safety glasses or goggles. Your eyes may be lower than some parts and pieces, and you don't want to lose an eye.

Remove the possibility of any electrical issues by disconnecting the negative battery cable.

KIT CLEARANCE

There must be a minimum of 1/2" clearance around all installed components when the air springs are inflated and under a load. The air springs must flex and expand during operation, so the clearance keeps the kit from rubbing against parts of the vehicle.

VEHICLE GVWR

NEVER exceed the maximum load recommended by the vehicle manufacturer (GVWR). The GVWR can be found in your vehicle's owner's manual or on the data plate on the driver's side door. Consult your local dealership for additional GVWR specifications.

INFLATING THE AIR SPRINGS

When inflating air springs, add air pressure in small quantities, checking air pressure frequently. The air springs have much less air volume than a tire, so they inflate much more quickly.

PRESSURE TO LOAD

The air springs will support approximately 50 lbs. of load for each PSI of inflation pressure (per pair). For example, 50 PSI of inflation pressure will support a load of 2500 lbs. per pair of air springs.

APPROPRIATE AIR PRESSURE

For best ride, use only enough air pressure in the air springs to level the vehicle when viewed from the side (front to rear). This will vary, depending on the load, location of the load, condition of the existing suspension, and personal preference.

OPTIONAL T-FITTING

This kit includes inflation valves and air line tube for each air spring, allowing you to compensate for unbalanced loads. If you prefer a single inflation valve system to provide equal pressure to both air springs, your dealer can supply the optional "T" fitting (Part # 3025 or WRI-760-3461 retail pack).



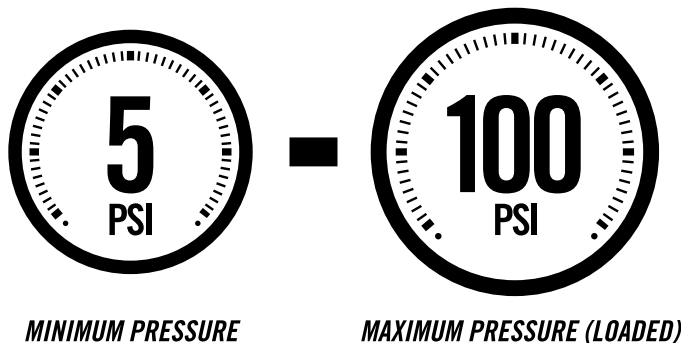

ONCE INSTALLED SUCCESSFULLY, FOLLOW THESE PRESSURE REQUIREMENTS FOR THE AIR SPRINGS:



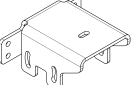
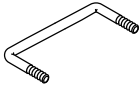
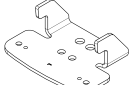

PARTS

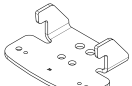
Compare the parts below to your kit. Assure you have all pieces, and organize them for an easier installation.













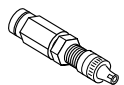

MAIN KIT CONTENTS

PT # 6397	 x2 AIR SPRING	PT # 5878	 x2 LOWER AIR SPRING BRACKET	PT # 3077	 x2 BAIL CLAMP
PT # 5872	 x1 UPPER LEFT BRACKET	PT # 5876	 x2 AXLE STRAP BRACKET	PT # 1004	 x1 HEAT SHIELD
PT # 5873	 x1 UPPER RIGHT BRACKET	PT # 5882	 x2 AXLE SADDLE BRACKET	PT # 9415	 x1 AIR LINE TUBE (22 FEET)

A24-760-7560 INFLATION VALVE BRACKET KIT

PT # 9483	 x1 NO-DRILL INFLATION VALVE BRACKET	PT # 9488	 x2 LARGE NYLON TIE
-----------	---	-----------	---

A21-760-2504 HARDWARE PACK

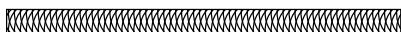
PT # 3370	 x4 3/8" - 16 x 3/4" FLAT HEAD SCREW	PT # 3067	 x12 3/8" - 16 FLANGE LOCK NUT	PT # 3032	 x2 INFLATION VALVE AND VALVE CAP ASSEMBLY
PT # 3033	 x4 5/16" FLAT WASHER	PT # 3493	 x12 3/8" FLAT WASHER	PT # 3055	 x2 AIR FITTING
PT # 3069	 x2 3/8" - 16 x 3/4" FLANGE BOLT	PT # 3332	 x2 5/8" - 18 NYLON JAM NUT	PT # 3482	 x4 3/8" - 16 x 3.5" CARRIAGE BOLT
PT # 3505	 x2 10 - 24 x 2" THREADED ROD	PT # 3504	 x4 3/8" - 16 FRAME NUT	PT # 9036	 x6 RED NYLON TIE
PT # 3338	 x8 3/8" - 16 x 1" HEX HEAD BOLT	PT # 3488	 x4 3/8" - 16 NYLOCK NUT	PT # 0899	 x2 THERMAL SLEEVE

CONTENTS AND OVERVIEW

PAGE **4** REMOVE JOUNCE BUMPER & INSTALL FRAME NUTS

PAGE **5** INSTALL UPPER BRACKET

PAGE **6** FASTEN AIR SPRING TO UPPER BRACKET

PAGE **7** INSTALL LOWER BRACKET ASSEMBLY

PAGE **8** SECURE LOWER BRACKET ASSEMBLY

PAGE **9** HEAT SHIELD & PASSENGER SIDE

PAGE **10** AIR LINE TUBE & INFLATION VALVE INSTALLATION

PAGE **11** INSTALL & ROUTE AIR LINE TUBE

PAGE **12** CHECKING THE SYSTEM

PAGE **13** FIXING AN AIR LEAK

PAGE **14** FINISHING THE INSTALLATION

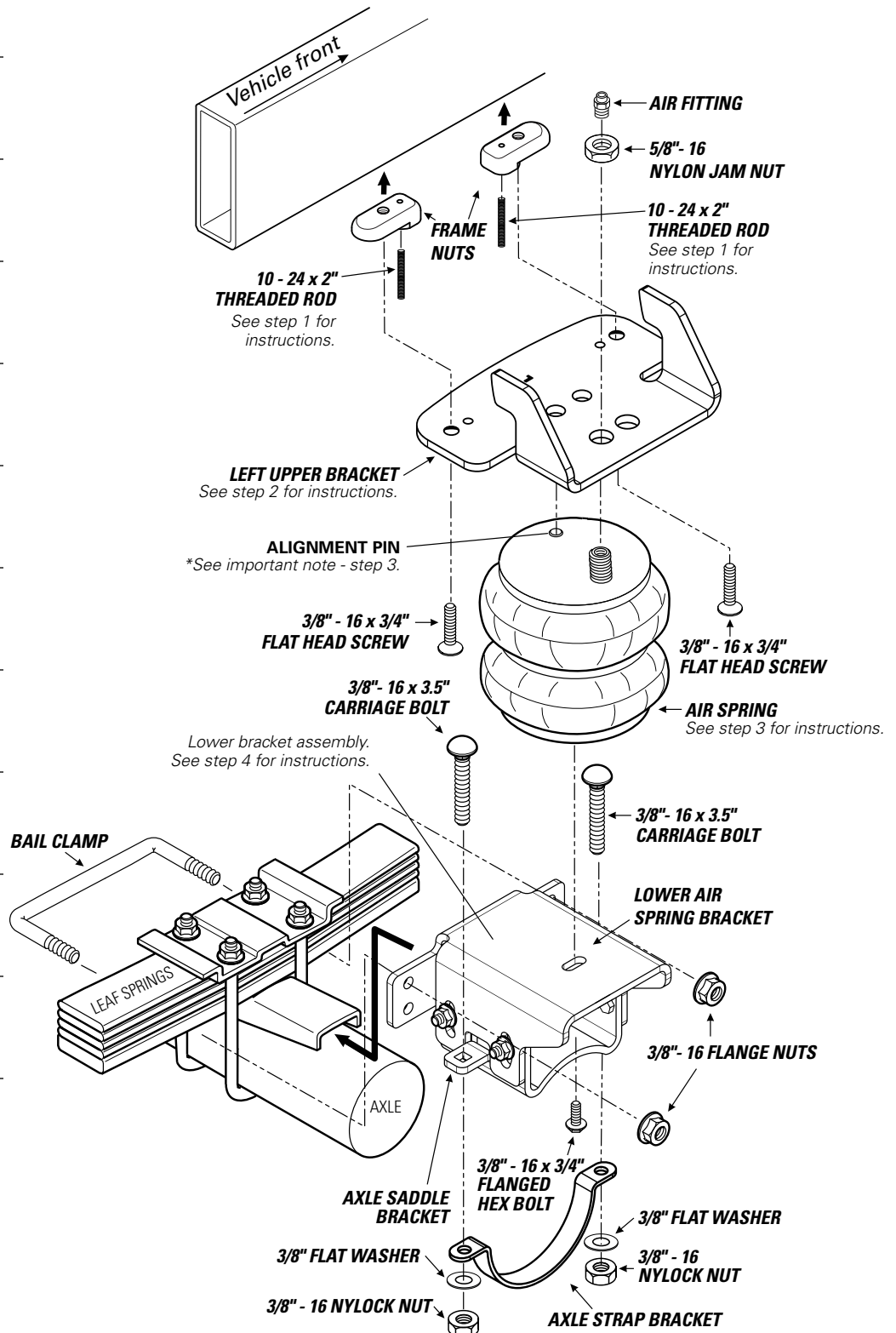

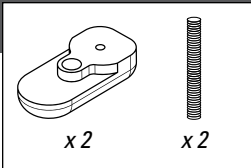

START THE INSTALLATION ON THE LEFT SIDE OF THE VEHICLE WHEN FACING FORWARD.

1 Remove the jounce bumper and the two studs holding it on. The two studs can be pried out with a flat head screw driver.

2 Thread the 10 - 24 x 2" threaded rods onto the frame nuts. These act as a grip to assist in installation.

3 Insert the frame nuts into the hole in the frame where you removed the jounce bumper studs, seating the frame nuts so they are flush with the vehicle frame.

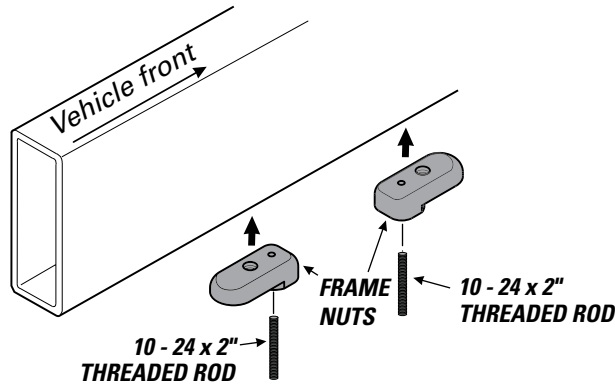

VIEW FROM BELOW

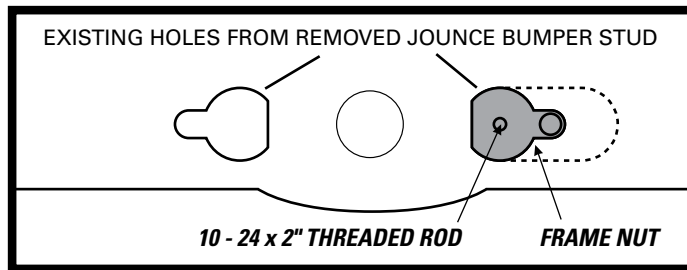

VIEW FROM SIDE

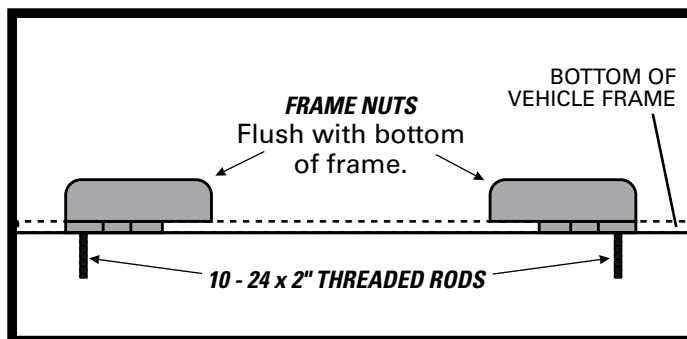

2

INSTALL UPPER BRACKET

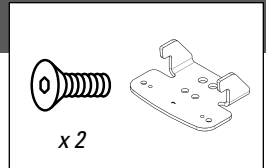

1 Using the threaded rods as guides, slide the upper bracket into place, secure against the bottom of the vehicle frame.

2 Fasten upper bracket to the frame using the flat head screws, as shown.

3 Remove the threaded rods and save them for installation on the other side of the vehicle.

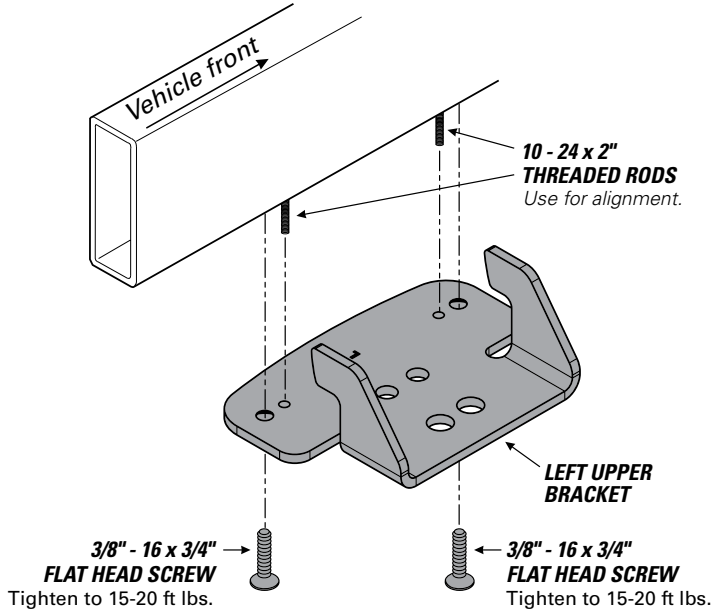

REMOVE THREADED RODS AFTER SECURING THE UPPER BRACKET. FAILURE TO DO SO COULD CAUSE THEM TO PUNCTURE THE AIR SPRING, RESULTING IN AN AIR SPRING FAILURE THAT IS **NOT WARRANTABLE.**

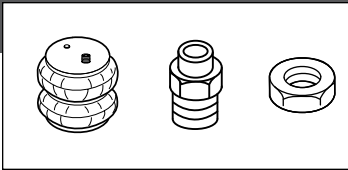

INSTALLING THE RIGHT SIDE? REMEMBER TO INSTALL THE HEAT SHIELD IN STEP 7 FIRST!

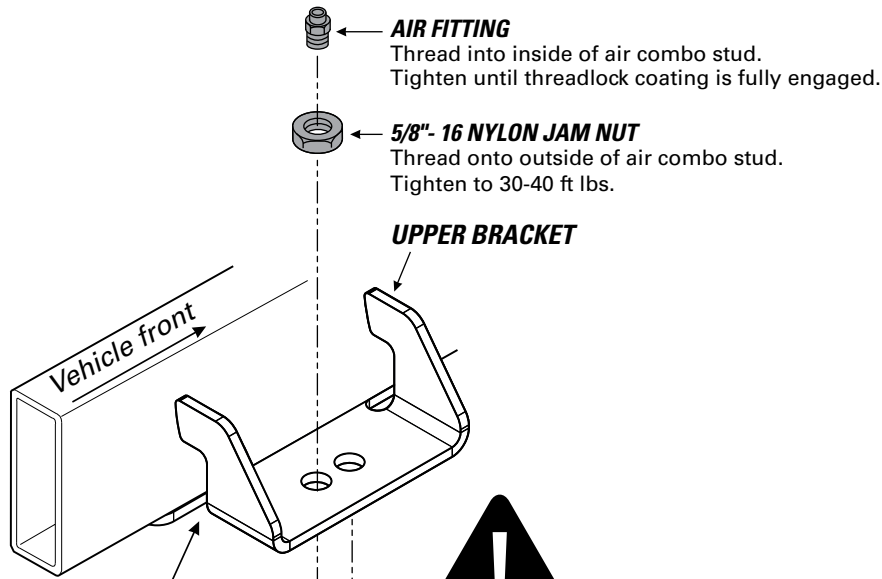

ALIGNMENT PIN ON AIR SPRINGS MUST BE INSTALLED TO FULLY SEAT INTO THE FRONT ALIGNMENT HOLE IN THE UPPER BRACKET. FAILURE TO DO SO WILL CAUSE IT TO BE PUSHED INTO THE BEAD PLATE, CREATING AN AIR LEAK, AND RESULTING IN AN AIR SPRING FAILURE THAT IS **NOT WARRANTABLE. THE ALIGNMENT PIN CANNOT HOLD 2,500 LBS! IT IS USED FOR ALIGNMENT ONLY!**

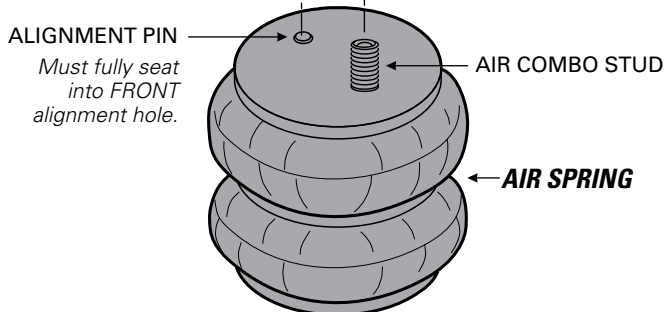
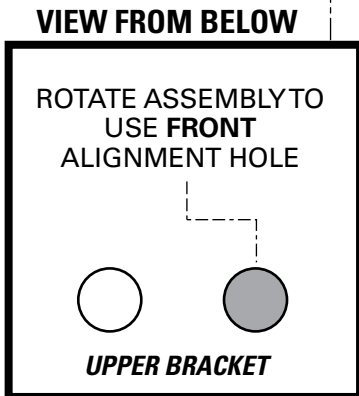

4

INSTALL LOWER BRACKET ASSEMBLY

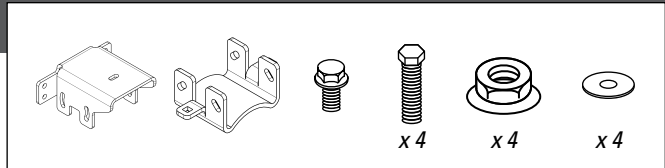

1 Follow steps below to dry fit assembly. Make alignment marks as shown.

2 Place bottom of axle saddle bracket on the axle of the vehicle.

3 Place the upper bracket above the axle saddle bracket as shown. Assure both are tight against the leaf spring stack.

4 Match the alignment marks and secure the air spring to the upper bracket, as shown.

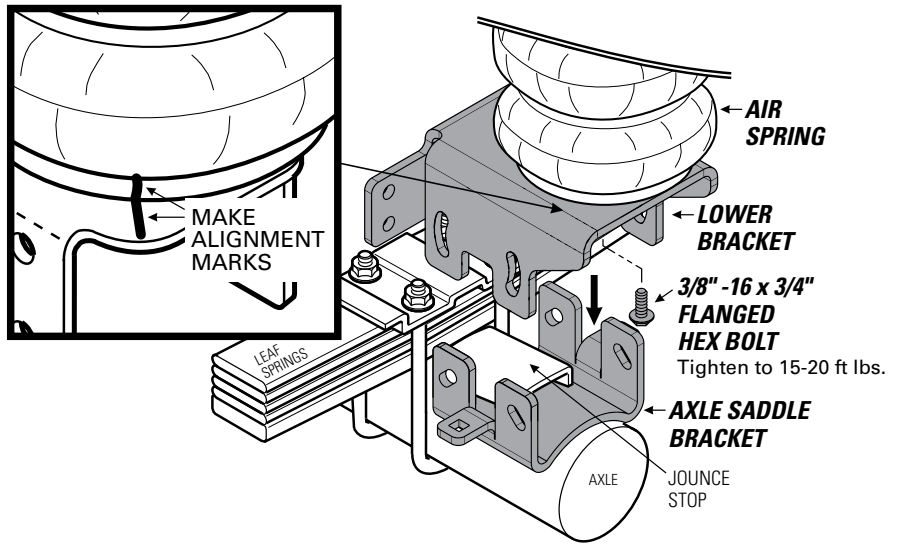

5 Position the lower bracket **as low as possible**, while still clearing the jounce stop on the vehicle. See figure below for design height.

6 Making sure the lower bracket is parallel to the ground, insert the bolts from the inside of the lower bracket assembly.

7 Use supplied fasteners to secure the lower bracket to the axle saddle bracket for form the lower bracket assembly.

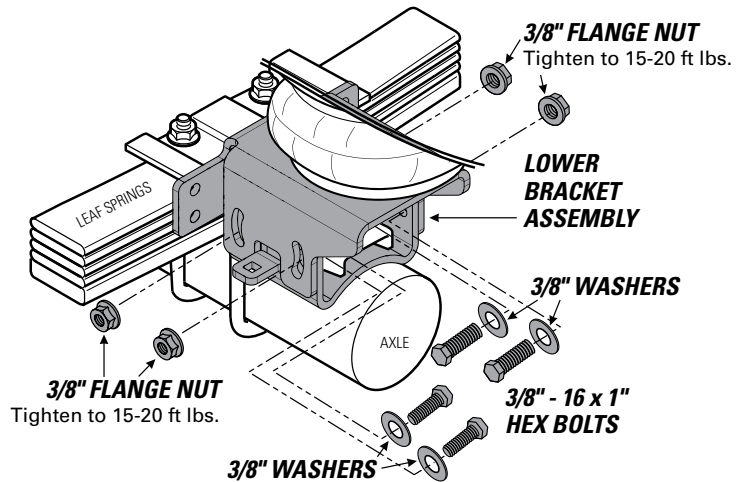

5 1/2" - 6 1/2"

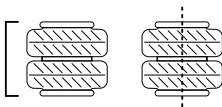

AIR SPRING DESIGN HEIGHT

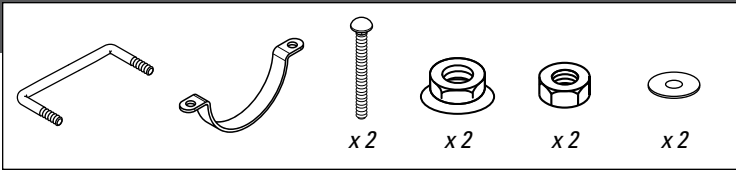

!

USE YOUR HAND TO CHECK FOR THE PROPER CLEARANCE AROUND THE AIR SPRING. IF YOUR HAND DOES NOT FIT BETWEEN THE AIR SPRING AND OTHER COMPONENTS, IT WILL RUB!

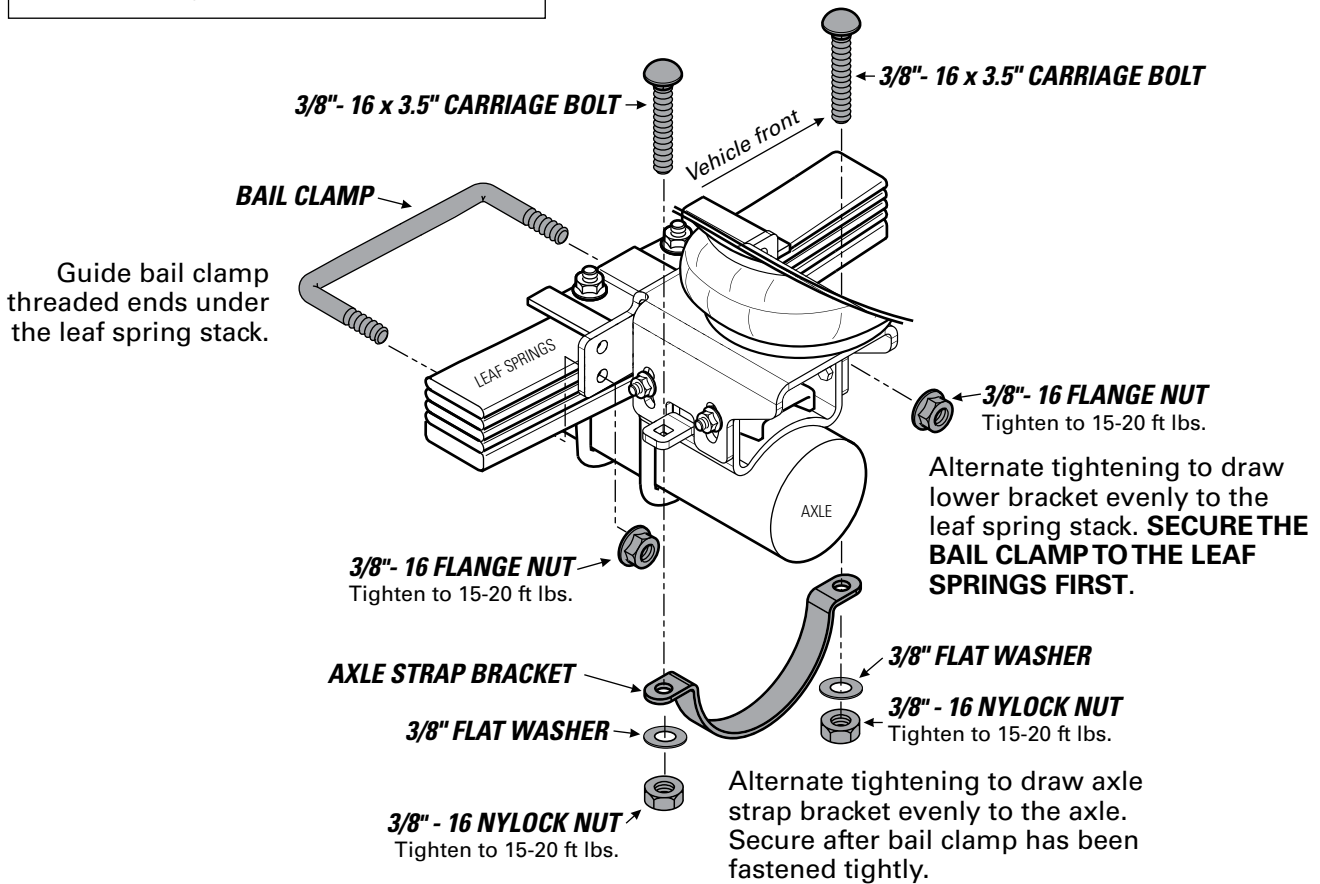
AWESOME! You're done with the left side. The right side is the same, with the addition of the heat shield. See step 7, then complete the steps for the right side installation.

6

INSTALL RIGHT SIDE WITH HEAT SHIELD



RIGHT SIDE INSTALLATION MUST INCLUDE HEAT SHIELD!

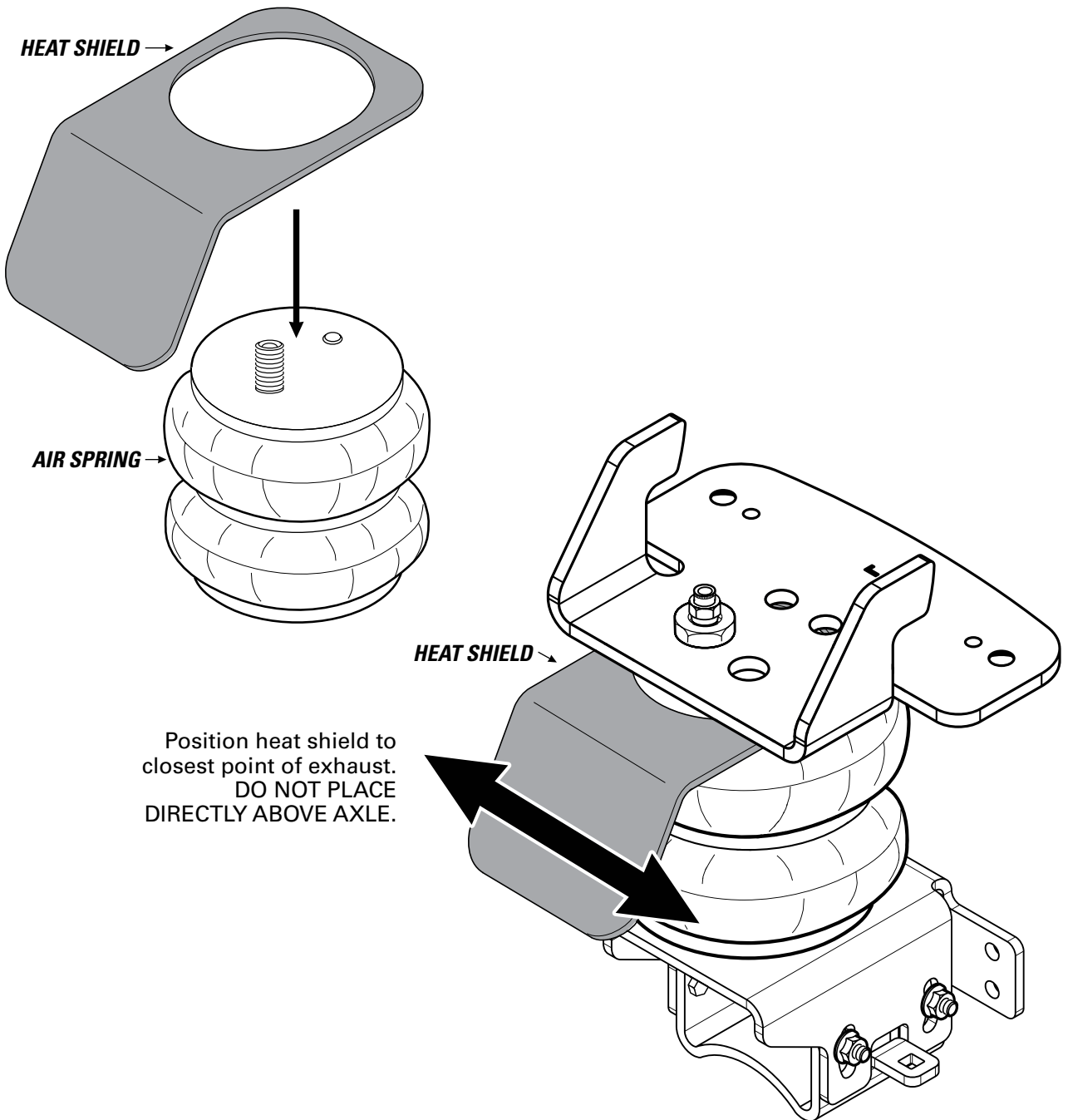

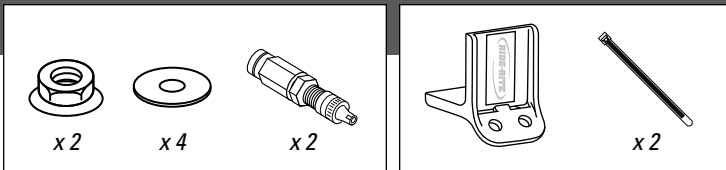

IF USING THE OPTIONAL NO-DRILL INFLATION VALVE BRACKET, CHOOSE OPTION 1. IF DRILLING, CHOOSE OPTION 2. **INFLATION VALVES MUST BE ACCESSIBLE BY AN AIR CHUCK.**

1 Secure the air inflation valve bracket to a protected, secure location. **PROCEED TO STEP 3.**

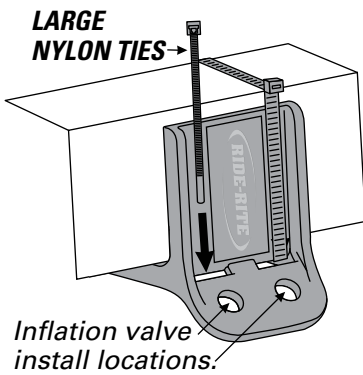

2 Select a protected location to install the inflation valves, such as the bumper or the body of the vehicle.

Drill two 5/16" holes for inflation valve install locations.

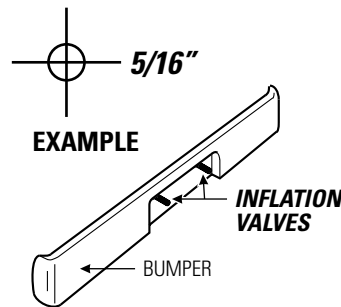

3 Install inflation valve assembly as shown.

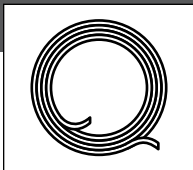
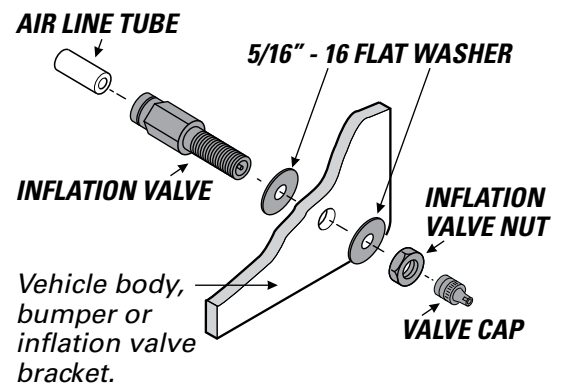

1 Match air line tube ends.

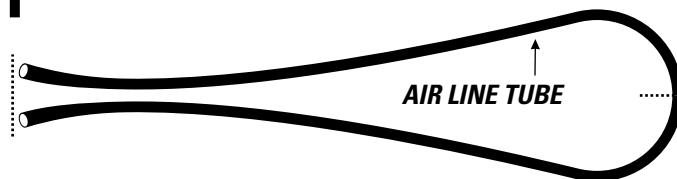

2 Find center of air line tube, make a square cut with tube cutter or sharp utility knife.

DO

Make sure the cut is as square as possible. Use a tube cutter or sharp utility knife.

DON'T

Fold or kink the air line tube. Cut the air line tube at an angle. Use pliers, scissors, snips, Saws, or side cutters.

PROPER AND IMPROPER CUTS IN THE AIR LINE TUBE

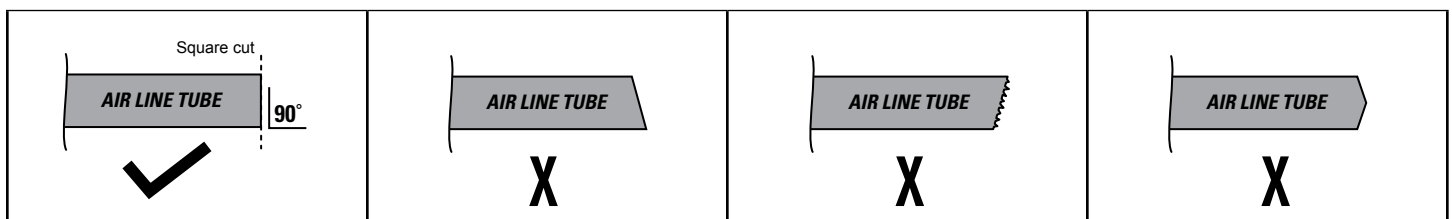

9

INSTALLING AIR LINE TUBE INTO AIR FITTINGS AND INFLATION VALVE

1 Insert end of air line tube into air fitting.

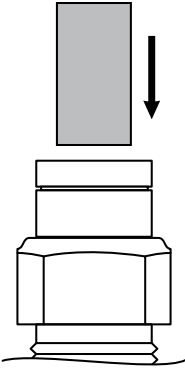

2 Push air line tube into air fitting as far as possible.

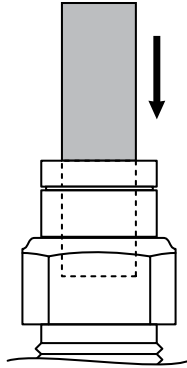

3 Gently pull on the air line tube to check for a secure fit.

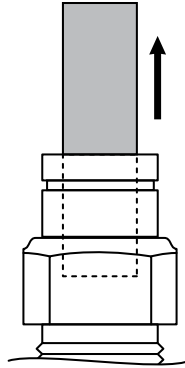

4 To remove, push down collar and gently pull air line tube away.

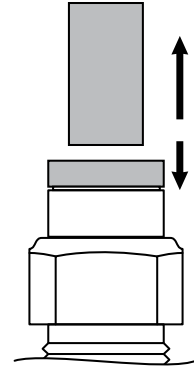

Removal Tip: Use a 1/4", 5/16", or 6mm open-ended wrench to push the collar down.

10

ROUTE AND SECURE AIR LINE TUBES

Air line tube routes will vary, depending on your truck, and requires you to choose the best path from the air springs to the inflation valves. Use the instructions below to help you choose.

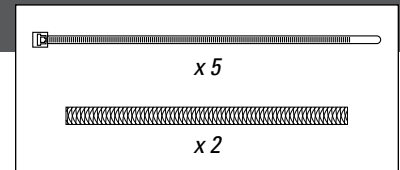

DO

Select routes protected from heat, Debris, and sharp edges.
Use thermal shields near heat sources.
Use Nylon ties to secure the air line tube.

DON'T

Bend or sharply curve air line tubes.
Leave air line tube exposed to sharp edges.
Use unnecessary lengths of air line tube.
Route air line tube near moving parts.
Let air line tube hang unsecured from vehicle.
Scar air line tube while routing.

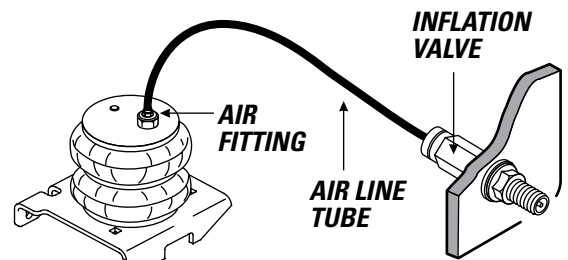
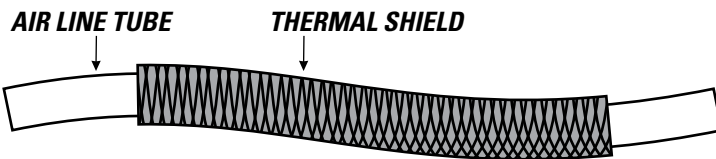

USE SUPPLIED THERMAL SHIELDS WHEN AIR LINE TUBE RUNS **WITHIN 6 INCHES** OF HEAT SOURCES.



- 1** Place an air chuck onto the inflation valve and fill the system to **70 PSI**.

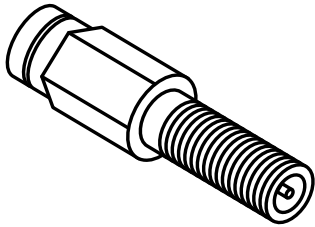

AIR SPRINGS INFLATE QUICKLY. CHECK AIR PRESSURE WHILE INFLATING.

- 2** Spray fittings with soap and water mixture or glass cleaner.



- 3** Observe bubbles.

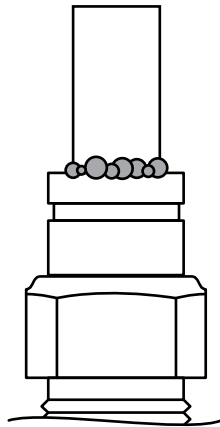

**SMALL SOAP BUBBLES
THAT DO NOT EXPAND**

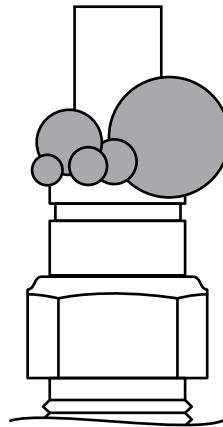

**SOAP BUBBLES
THAT EXPAND**



NO LEAKS?

Congratulations! Continue to step 13 to finish installation. Review the Operating Instructions.

LEAK?

Bummer. Continue to step 12 to fix the leak.

12

FIXING AN AIR LEAK

- 1 Press the air valve on end of inflation valve to release all air pressure.

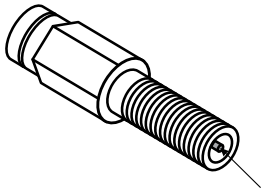

AIR VALVE



EXHAUST ALL AIR FROM THE SYSTEM PRIOR TO RELEASING AIR LINE TUBES FROM AIR FITTINGS.

LEAK AT AIR LINE TUBE AND AIR FITTING

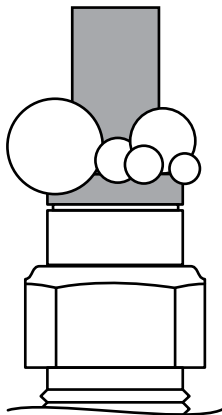

Release air line tube (see page 11). Review proper cuts and procedures in step 8. Repeat steps 9 and 11.

LEAK AT BASE OF AIR FITTING ON AIR SPRING

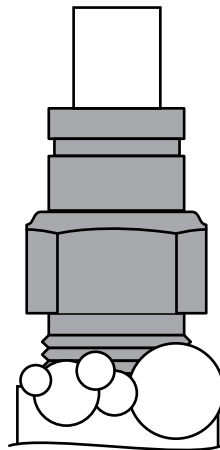

Tighten air fitting one turn or until leak stops.

LEAK OUT OF THE VALVE CORE ON INFLATION VALVE

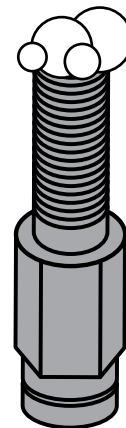

Tighten valve core with valve core wrench on inflation valve cap.

STILL HAVE A LEAK?

Refer to the Troubleshooting section of the Instruction Manual. If the leak persists, or if there is an issue with a leaking part, call 1-800-888-0650; Option 1; Option 1 for Technical Support.

SAFELY RETURN VEHICLE TO OPERATIVE STATE

If you removed any wheels during installation, install the wheels and torque the lug nuts to the manufacturer's specifications.

Safely remove any jack stands and wheel chocks used during installation.

Re-attach the negative battery cable.

DOUBLE-CHECK AIR SPRING CLEARANCE

Check the air springs once again for the proper 1/2" minimum clearance. Perform clearance check again when vehicle is under load.

VEHICLE GVWR

NEVER exceed the maximum load recommended by the vehicle manufacturer (GVWR). The GVWR can be found in your vehicle's owner's manual or on the data plate on the driver's side door. Consult your local dealership for additional GVWR specifications.

READ AND UNDERSTAND THE OPERATING INSTRUCTIONS

The Ride-Rite system can improve handling and comfort. Take the time to learn how to properly use and maintain your investment by reading the Operating Instructions.



USE YOUR HAND TO CHECK FOR THE PROPER CLEARANCE AROUND THE AIR SPRING. IF YOUR HAND DOES NOT FIT BETWEEN THE AIR SPRING AND OTHER COMPONENTS, IT WILL RUB!

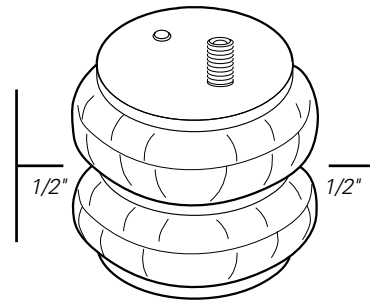

! IMPORTANT

A MINIMUM OF 5 PSI MUST BE MAINTAINED IN THE AIR SPRINGS AT ALL TIMES

Too much air pressure in the air springs will result in a firmer ride, while too little air pressure will allow the air springs to bottom out over rough conditions, and will not provide the improvement in handling that is possible.



MINIMUM PRESSURE



MAXIMUM PRESSURE (LOADED)



riderite.com

BEFORE YOU DRIVE, CONFIRM THE FOLLOWING:

- Do you have a minimum of 5PSI in your air springs?
- Are your air springs standing 5 1/2" - 6 1/2" tall?
- Are your air springs properly aligned, left-to-right and front-to-back?
- Are your nuts and bolts tight?
- Put your paper work back into the sleeve and keep it in your glove compartment for future reference.
- You've been bagged...and now your suspension is Airide™ equipped! Show it off with the supplied decal!

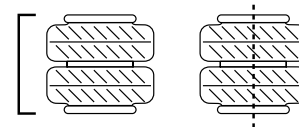

NEED INSTALLATION HELP? 1-800-888-0650

Select Option 1 for Ride-Rite; Select Option 1 for Technical Support.

Or, email us at rrtech@fsip.com. If emailing, please include photos to help us better diagnose and understand any problems you may be experiencing.

Firestone

Firestone Industrial Products

CONNECT WITH US



FirestoneIP



Firestone Ride-Rite