

**CLASS 2 TRAILER HITCH
R2-0158**

Chrysler Town and Country w/ Stow 'n Go

TOOLS REQUIRED:
DRILLS: NONE
WRENCHES: 18mm, 15mm

3,500 LB GROSS TRAILER WEIGHT, 300 LB TONGUE WEIGHT. WARNING: CONSULT VEHICLE OWNERS MANUAL FOR TOWING RECOMMENDATIONS AND LIMITATIONS. THIS PRODUCT IS DESIGNED FOR TRAILER TOWING ONLY AND SHOULD NOT BE USED FOR ANY OTHER PURPOSE.

WARNING: USE ONLY RIGID HITCH APPROVED AND MANUFACTURED DRAW BAR INSERT OR WARRANTY WILL BE VOID

NOTE: INSTALL PARTS LOOSELY UNTIL ALL ATTACHMENTS HAVE BEEN MADE TO VEHICLE

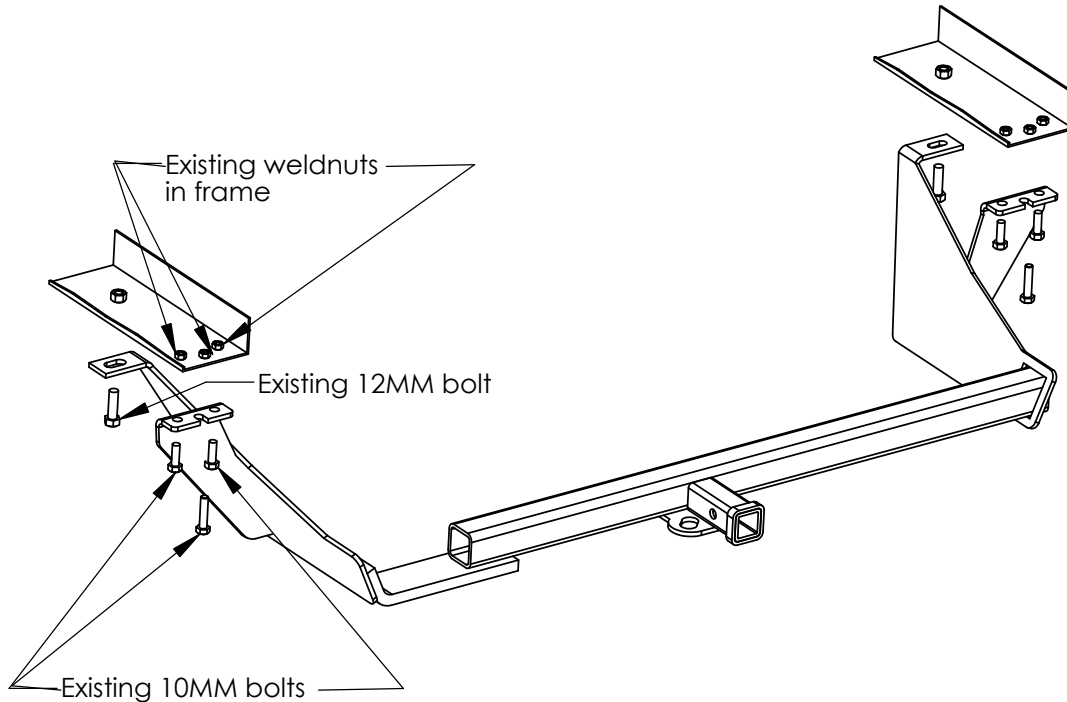

1. Remove (3) rearmost spring shackle mounting bolts, from each side, and retain for hitch installation. See Figure 1-1
2. Remove the 12MM bolt just forward of the spring shackle on each side, and retain for hitch installation.
3. Raise hitch into position, and attach with the metric bolts removed in steps one and two.
4. Tighten all fasteners to the appropriate torque specifications.

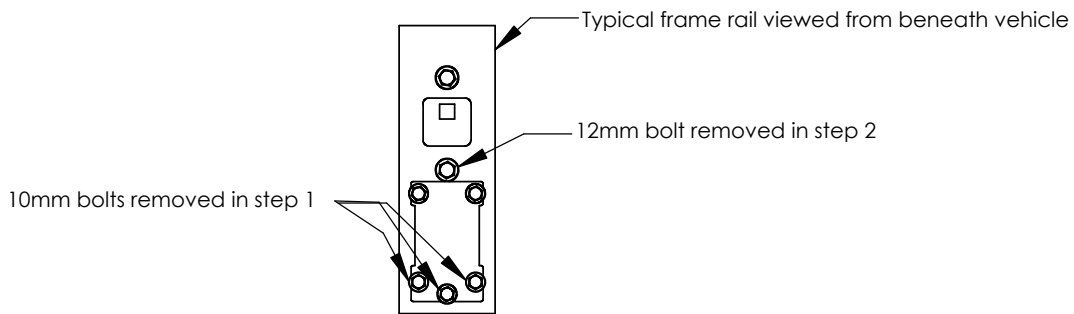

Rear of vehicle

Figure 1-1

TIGHTEN ALL FASTENERS TO THE TORQUE SPECIFICATIONS SHOWN BELOW

GIVE THIS INSTRUCTION SHEET TO VEHICLE OWNER

BOLT TIGHTENING TORQUE (LB-FT)			
BOLT SIZE	TORQUE	BOLT SIZE	TORQUE
3/8"	25 LB FT	8MM	20 LB FT
7/16"	50 LB FT	10MM	38 LB FT
1/2"	60 LB FT	12MM	68 LB FT
3/4"	120 LB FT		

THIS PRODUCT COMPLIES WITH SAFETY SPECIFICATIONS AND REQUIREMENTS FOR SAE AND VESC REGULATION V-5 FOR CONNECTING DEVICES AND TOWING SYSTEMS. DO NOT MODIFY THIS PRODUCT. INSTALL ONLY ON SPECIFIED VEHICLES IN GOOD CONDITION.

RIGID[®]
HITCH INCORPORATED
3301 WEST BURNSVILLE PARKWAY
BURNSVILLE, MN 55337

REV.
4/06