

CLASS 2 TRAILER HITCH
R2-0354
Toyota Camry/ Solara

TOOLS REQUIRED:
DRILLS: 1/2"
WRENCHES: 11/16, 14mm, 17mm

3,500 LB GROSS TRAILER WEIGHT, 300 LB TONGUE WEIGHT. WARNING: CONSULT VEHICLE OWNERS MANUAL FOR TOWING RECOMMENDATIONS AND LIMITATIONS. THIS PRODUCT IS DESIGNED FOR TRAILER TOWING ONLY AND SHOULD NOT BE USED FOR ANY OTHER PURPOSE.

WARNING: USE ONLY RIGID HITCH APPROVED AND MANUFACTURED DRAW BAR INSERT OR WARRANTY WILL BE VOID

NOTE: INSTALL PARTS LOOSELY UNTIL ALL ATTACHMENTS HAVE BEEN MADE TO VEHICLE

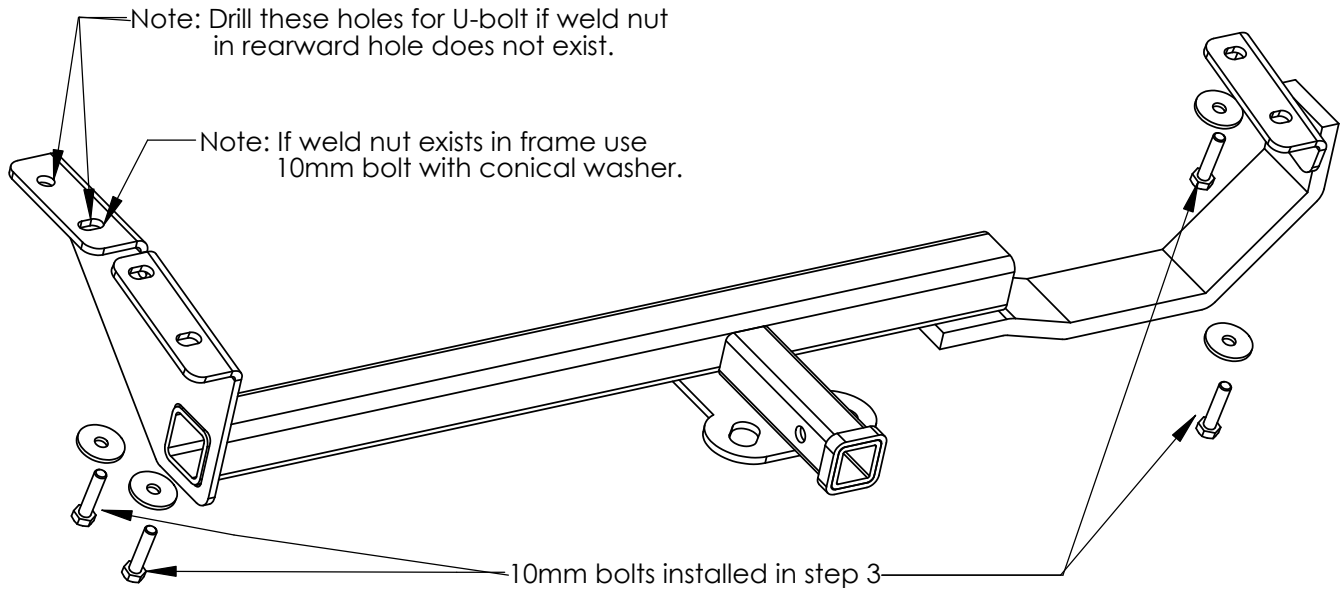

1. If present, remove the tie down brackets and bolts from each side of the vehicle frame. Return to owner. Note: On vehicles with muffler hanger bracket welded to the passenger side tie down bracket, the tie down bracket/muffler hanger will be re-attached with hitch in step 3.
2. On vehicles with muffler hanger bracket bolted to the bottom of the frame rail on passenger side, remove the bolts that attach bracket to frame.
3. Raise hitch into position and attach with (4) 10mm bolts and conical washers as shown above. Note: Muffler hanger bracket or tie down/muffler hanger bracket will be bolted to the bottom side of the hitch bracket up into the frame.
 - For (2) bolt exhaust hanger configuration, use the (2) 10mm bolts and conical washers provided.
 - For (4) bolt exhaust hanger configuration, use (2) 10mm bolts removed in step 1, and (2) 10mm bolts and conical washers provided with the hitch.
4. If existing weld nut is present in location shown above, **do not** use the U-bolt. Insert the 10mm bolt and conical washer provided.
5. For vehicles without existing weld nut, use the hitch as a template and drill the (2) 1/2" holes required for the U-bolt.
6. Thread the U-bolt up into one of the drilled holes and into the frame, then down through the other drilled hole. Attach with the conical washers and nuts provided. Note: It will be necessary to lower the hitch to thread the U-bolt into the frame rail.

Note: Due to different configurations, there will be excess hardware.

TIGHTEN ALL FASTENERS TO THE TORQUE SPECIFICATIONS SHOWN BELOW

HARDWARE PACKAGE:

(5) 10mm x 1.25 x 40mm hex bolts	(2) 3/8-16 hex nuts
(1) 3/8-16 U-bolt	(1) R2-0206 Drawbar Kit
(6) 3/8 conical washers	

GIVE THIS INSTRUCTION SHEET TO VEHICLE OWNER

BOLT TIGHTENING TORQUE (LB-FT)			
BOLT SIZE	TORQUE	BOLT SIZE	TORQUE
3/8"	25 LB FT	8MM	20 LB FT
7/16"	50 LB FT	10MM	38 LB FT
1/2"	60 LB FT	12MM	68 LB FT
3/4"	120 LB FT		

THIS PRODUCT COMPLIES WITH SAFETY SPECIFICATIONS AND REQUIREMENTS FOR SAE AND VESC REGULATION V-5 FOR CONNECTING DEVICES AND TOWING SYSTEMS. DO NOT MODIFY THIS PRODUCT. INSTALL ONLY ON SPECIFIED VEHICLES IN GOOD CONDITION.

RIGID[®]
HITCH INCORPORATED
3301 WEST BURNSVILLE PARKWAY
BURNSVILLE, MN 55337

REV.
5/06