

CLASS 2 TRAILER HITCH
R2-0384
 Toyota Camry/ Camry Hybrid

TOOLS REQUIRED:
 DRILLS: 1/2"
 WRENCHES: 14mm, 17mm, 3/4"

3,500 LB GROSS TRAILER WEIGHT, 300 LB TONGUE WEIGHT. WARNING: CONSULT VEHICLE OWNERS MANUAL FOR TOWING RECOMMENDATIONS AND LIMITATIONS. THIS PRODUCT IS DESIGNED FOR TRAILER TOWING ONLY AND SHOULD NOT BE USED FOR ANY OTHER PURPOSE.

WARNING: USE ONLY RIGID HITCH APPROVED AND MANUFACTURED DRAW BAR INSERT OR WARRANTY WILL BE VOID

NOTE: INSTALL PARTS LOOSELY UNTIL ALL ATTACHMENTS HAVE BEEN MADE TO VEHICLE

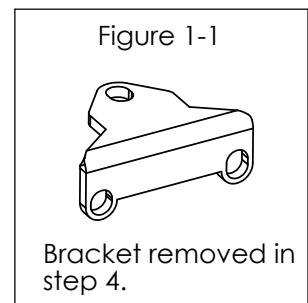
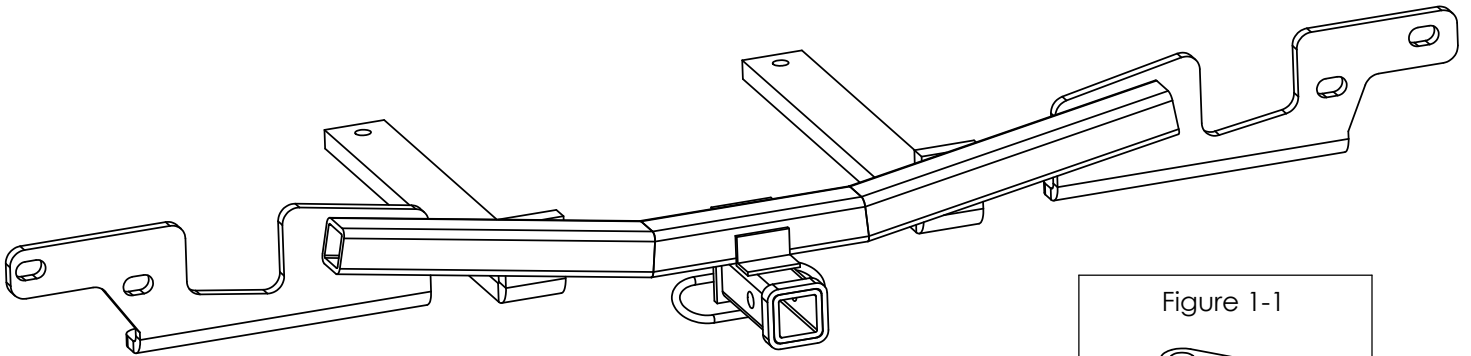

1. Remove the spare tire from the trunk of the vehicle.
2. Lower the exhaust by removing the rubber exhaust hangers.
3. Carefully remove the plastic rivets from the fascia tabs between the trunk pan and the rear fascia. These will be reinstalled later. If present, remove the plastic trunk pan cover, and return to vehicle owner.
Toyota Camry Hybrid: Remove the plastic fascia covering the side frame rail. Return fascia and screws to vehicle owner.
4. Remove the existing bracket shown in Figure 1-1 from the driver's side frame rail and the rear end panel and return to vehicle owner.
5. Raise the hitch into position and install the (4) 10mm hex bolts and conical washers into the existing weld nuts in the rear panel.
6. Using the hitch as a template drill the two 1/2" mounting holes in the trunk pan.
7. Scrape the foam rubber material away from the inside of the trunk pan around the holes drilled in step 6.
8. Install the 1/2" carriage bolts and block plates inside the trunk pan, down through the drilled holes and through the holes in the hitch. Attach with lock washers and hex nuts provided.
9. Reattach the rubber exhaust hangers and reinsert the fascia rivets removed in step 3.
10. Reinstall the spare tire in trunk pan.

TIGHTEN ALL FASTENERS TO THE TORQUE SPECIFICATIONS SHOWN BELOW

Hardware Package:	(4) 10mm x 40 x 1.25mm Hex Bolts	(2) 1/4 x 1-1/2 x 2" Sq. Hole Block Plates
	(4) 3/8" Conical Washers	(2) 1/2" Lock Washers
	(2) 1/2-13 x 1-3/4" Carriage Bolts	(2) 1/2" Hex Nuts
		(1) R2-0208-S Drawbar Kit

GIVE THIS INSTRUCTION SHEET TO VEHICLE OWNER

BOLT TIGHTENING TORQUE (LB-FT)			
BOLT SIZE	TORQUE	BOLT SIZE	TORQUE
3/8"	25 LB FT	8MM	20 LB FT
7/16"	50 LB FT	10MM	38 LB FT
1/2"	60 LB FT	12MM	68 LB FT
3/4"	120 LB FT		

THIS PRODUCT COMPLIES WITH SAFETY SPECIFICATIONS AND REQUIREMENTS FOR SAE AND VESC REGULATION V-5 FOR CONNECTING DEVICES AND TOWING SYSTEMS. DO NOT MODIFY THIS PRODUCT. INSTALL ONLY ON SPECIFIED VEHICLES IN GOOD CONDITION.

RIGID[®]
HITCH INCORPORATED
 3301 WEST BURNSVILLE PARKWAY
 BURNSVILLE, MN 55337

REV.
 4/07