

CLASS 2 TRAILER HITCH

R2-0514

Nissan Rogue

TOOLS REQUIRED:

DRILLS: NONE

WRENCHES: Ratchet, Torque Wrench, Socket Extension, 18mm, 19mm sockets

3,500 LB GROSS TRAILER WEIGHT, 300 LB TONGUE WEIGHT. WARNING: CONSULT VEHICLE OWNERS MANUAL FOR TOWING RECOMMENDATIONS AND LIMITATIONS. THIS PRODUCT IS DESIGNED FOR TRAILER TOWING ONLY AND SHOULD NOT BE USED FOR ANY OTHER PURPOSE.

WARNING: USE ONLY RIGID HITCH APPROVED AND MANUFACTURED DRAW BAR INSERT OR WARRANTY WILL BE VOID

NOTE: INSTALL PARTS LOOSELY UNTIL ALL ATTACHMENTS HAVE BEEN MADE TO VEHICLE

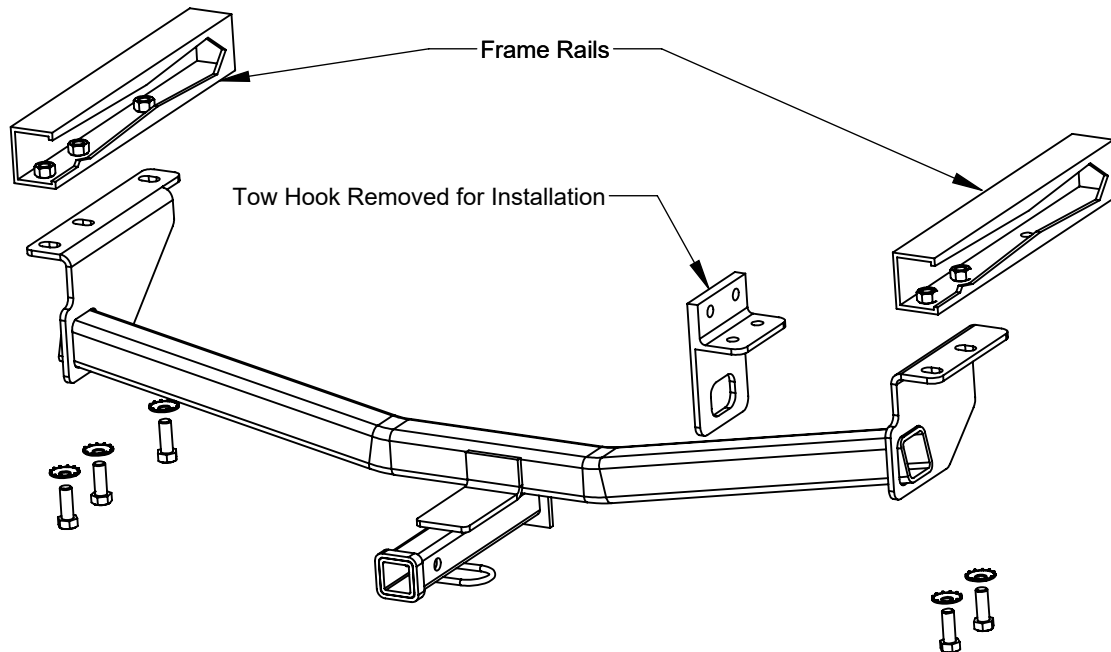

Note: Some models are equipped with appearance panels that cover the frame rails. Prior to installation remove the appearance panels. Return panels and plastic push pin fasteners to vehicle owner.

1. Remove the factory tow hook on the passenger side frame rail. Return tow hook and fasteners to vehicle owner.
2. Raise the hitch into position and secure with the 12mm hex bolts and conical washers provided. Note: the teeth on the conical washers go up against the hitch.
3. Tighten all fasteners to 75 LB-FT

Thank you for purchasing a Rigid Hitch

HARDWARE PACKAGE: (5) 12mm X 1.25 X 35mm hex bolts
(5) 1/2" conical washers
(1) R2-0108-S drawbar kit

GIVE THIS INSTRUCTION SHEET TO VEHICLE OWNER



THIS PRODUCT COMPLIES WITH SAFETY SPECIFICATIONS AND REQUIREMENTS FOR SAE J684 AND VESC REGULATION V-5 FOR CONNECTING DEVICES AND TOWING SYSTEMS. DO NOT MODIFY THIS PRODUCT. INSTALL ONLY ON SPECIFIED VEHICLES IN GOOD CONDITION.

RIGID[®]
HITCH INCORPORATED
3301 WEST BURNSVILLE PARKWAY
BURNSVILLE, MN 55337

REV.
11/18