

CLASS 2 TRAILER HITCH
R2-0850
 CHEVROLET IMPALA

TOOLS REQUIRED:
 DRILLS: 1/2"
 WRENCHES: 13mm, 9/16", 3/4"

3,500 LB GROSS TRAILER WEIGHT, 300 LB TONGUE WEIGHT. WARNING: CONSULT VEHICLE OWNERS MANUAL FOR TOWING RECOMMENDATIONS AND LIMITATIONS. THIS PRODUCT IS DESIGNED FOR TRAILER TOWING ONLY AND SHOULD NOT BE USED FOR ANY OTHER PURPOSE.

WARNING: USE ONLY RIGID HITCH APPROVED AND MANUFACTURED DRAW BAR INSERT OR WARRANTY WILL BE VOID

NOTE: INSTALL PARTS LOOSELY UNTIL ALL ATTACHMENTS HAVE BEEN MADE TO VEHICLE

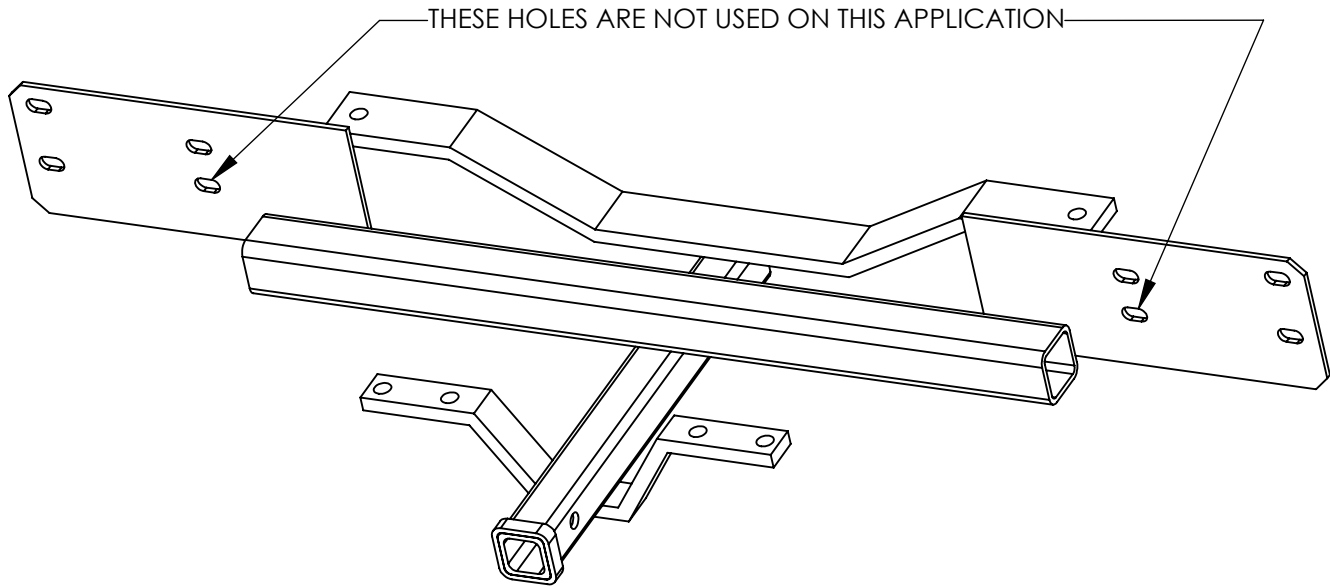

NOTE: IF DUAL EXHAUST IS PRESENT EXHAUST NEEDS TO BE LOWERED FROM HANGERS FOR INSTALLATION

1. REMOVE (6) 8MM BOLTS THAT ATTACH BUMPER TO FRAME
2. SLIDE EARS ON MAIN TUBE OF HITCH BETWEEN BUMPER AND FRAME
3. LOOSELY RE-INSTALL (6) 8MM BOLTS THROUGH THE FRAME, HITCH EARS, AND BUMPER
4. CENTER HITCH ON VEHICLE AND POSITION SO THAT REAR HANGER CONTACTS THE FLAT SURFACE OF THE BUMPER.
5. USING THE HITCH AS A TEMPLATE, DRILL THE FOUR HOLES IN BUMPER AND TWO HOLES IN FRAME CROSS MEMBER WITH 1/2" DRILL.
6. REMOVE THE (6) 8MM BOLTS THAT ATTACH BUMPER AGAIN AND REMOVE THE HITCH.
7. ASSEMBLE (2) 1/2" CARRIAGE BOLTS AND 1/2" SQ. HOLE BLOCK PLATES
8. USING FISHWIRE PROVIDED FISH CARRIAGE BOLT AND BLOCK PLATE ASSEMBLIES THROUGH ACCESS HOLES IN FRAME CROSS MEMBER INTO 1/2" DRILLED HOLES, AND INSERT (2) 3/8" SQ. U-BOLTS INTO HOLES DRILLED IN BUMPER.
9. USING CARE NOT TO PUSH BOLTS BACK UP INTO BUMPER AND FRAME, SLIDE EARS OF HITCH BETWEEN BUMPER AND FRAME, AND RAISE HITCH INTO POSITION.
10. LOOSELY INSTALL (4) 3/8" FLAT WASHERS, LOCK WASHERS AND NUTS ON TWO 3/8" U-BOLTS IN BUMPER, AND (2) 1/2" FLAT WASHERS, LOCK WASHERS AND NUTS ON CARRIAGE BOLTS IN FRAME.
11. RE-INSTALL (6) 8MM BOLTS THROUGH FRAME, HITCH EARS, AND BUMPER.
12. TIGHTEN ALL FASTENERS TO APPROPRIATE TORQUE SPECIFICATIONS AT THIS TIME

NOTE: RE-ATTACH HANGERS IF EXHAUST WAS LOWERED DURING INSTALLATION.

TIGHTEN ALL FASTENERS TO THE TORQUE SPECIFICATIONS SHOWN BELOW

HARDWARE PACKAGE:	(2) 3/8" SQ. U-BOLTS	(2) 1/2" LOCK WASHERS	(4) 3/8" HEX NUTS
	(2) 1/2-13 X 1-3/4" CARRIAGE BOLTS	(2) 1/2" HEX NUTS	(1) 1/2" FISH WIRE
	(2) 1/4 X 1 X 2 SQ. HOLE PLATES	(4) 3/8" FLAT WASHERS	(1) R2-0106-S DRAWBAR KIT
	(2) 1/2" FLAT WASHERS	(4) 3/8" LOCK WASHERS	

GIVE THIS INSTRUCTION SHEET TO VEHICLE OWNER

BOLT TIGHTENING TORQUE (LB-FT)			
BOLT SIZE	TORQUE	BOLT SIZE	TORQUE
3/8"	25 LB FT	8MM	20 LB FT
7/16"	50 LB FT	10MM	38 LB FT
1/2"	60 LB FT	12MM	68 LB FT
3/4"	120 LB FT		

THIS PRODUCT COMPLIES WITH SAFETY SPECIFICATIONS AND REQUIREMENTS FOR SAE AND VESC REGULATION V-5 FOR CONNECTING DEVICES AND TOWING SYSTEMS. DO NOT MODIFY THIS PRODUCT. INSTALL ONLY ON SPECIFIED VEHICLES IN GOOD CONDITION.

RIGID[®]
HITCH INCORPORATED
 3301 WEST BURNSVILLE PARKWAY
 BURNSVILLE, MN 55337