

CLASS 3 TRAILER HITCH

R3-0118

Chrysler Town and Country w/ Stow 'N Go
Dodge Grand Caravan w/ Stow 'N Go

TOOLS REQUIRED:

DRILLS: NONE

WRENCHES: 15mm, 18mm

HITCH RATING: 3,500 LBS WEIGHT CARRYING, 350 LBS TONGUE WEIGHT / 4,000 LBS WEIGHT DISTRIBUTING, 400 LBS TONGUE WEIGHT.
WARNING: CONSULT VEHICLE OWNERS MANUAL FOR TOWING RECOMMENDATIONS. DO NOT EXCEED VEHICLE'S RECOMMENDED TOWING CAPACITY. THIS PRODUCT IS DESIGNED FOR TRAILER TOWING ONLY AND SHOULD NOT BE USED FOR ANY OTHER PURPOSE.

NOTE: INSTALL PARTS LOOSELY UNTIL ALL ATTACHMENTS HAVE BEEN MADE TO VEHICLE

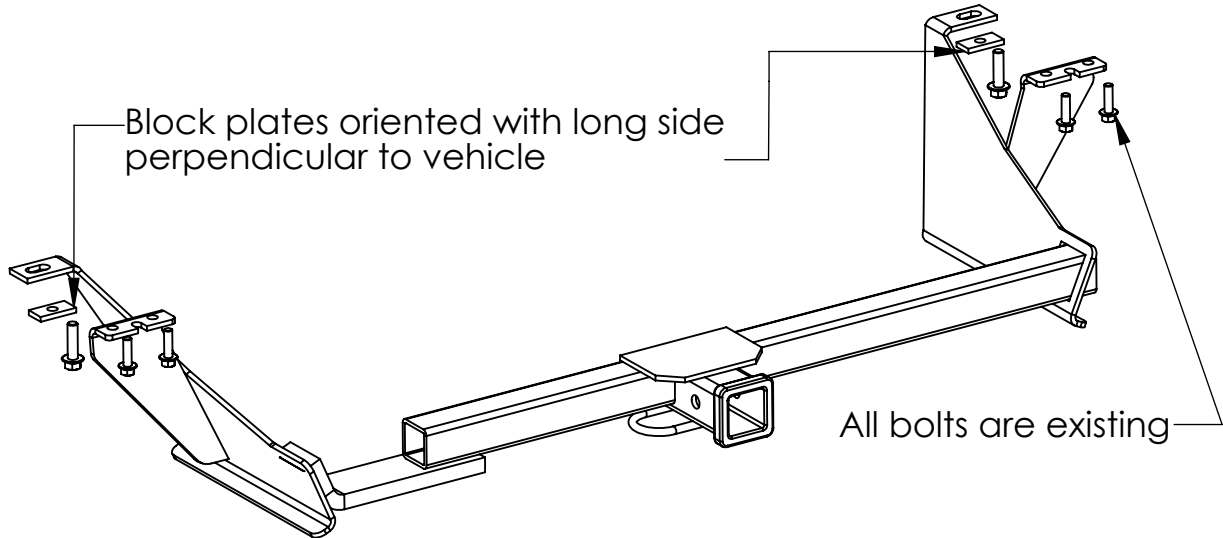

1. Remove (2) rearmost spring shackle mounting bolts from each side and retain for hitch installation. **Note: Remove only the two outer bolts see Figure 1-1.**
2. Remove the 12mm bolt just forward of the spring shackle on each side and retain for hitch installation
3. Raise hitch into position and attach with metric bolts removed in steps 1 and 2. **Note: Be sure to use block plates provided with the 12mm bolts removed in step 2 (see above illustration).**
4. Tighten all fasteners to the appropriate torque specifications.

Typical frame rail viewed from beneath vehicle

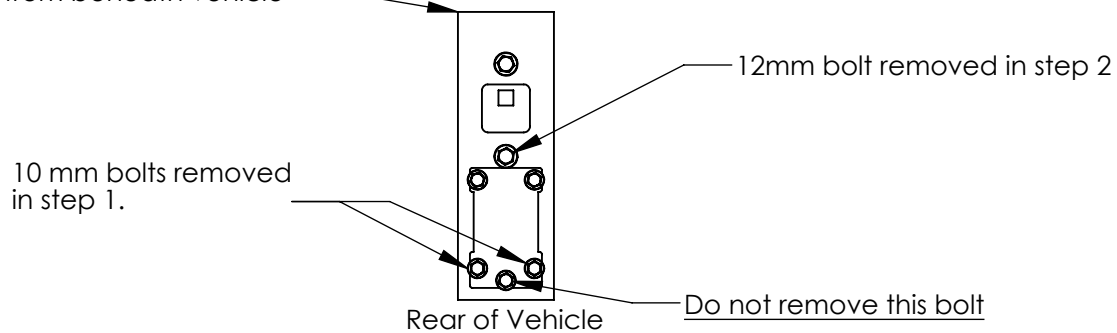

Figure 1-1

TIGHTEN ALL FASTENERS TO THE TORQUE SPECIFICATIONS SHOWN BELOW

Hardware Package: (2) 1/4 x 1-1/2 x 2 block plates 1/2" round hole

GIVE THIS INSTRUCTION SHEET TO VEHICLE OWNER

BOLT TIGHTENING TORQUE (LB-FT)			
BOLT SIZE	TORQUE	BOLT SIZE	TORQUE
3/8"	25 LB FT	8MM	20 LB FT
7/16"	50 LB FT	10MM	38 LB FT
1/2"	60 LB FT	12MM	68 LB FT
3/4"	120 LB FT		

THIS PRODUCT COMPLIES WITH SAFETY SPECIFICATIONS AND REQUIREMENTS FOR SAE AND VESC REGULATION V-5 FOR CONNECTING DEVICES AND TOWING SYSTEMS. DO NOT MODIFY THIS PRODUCT. INSTALL ONLY ON SPECIFIED VEHICLES IN GOOD CONDITION.

RIGID[®]
HITCH INCORPORATED
3301 WEST BURNSVILLE PARKWAY
BURNSVILLE, MN 55337

REV.
11/09