

CLASS 1 TRAILER HITCH

RT-382

Honda CR-V

TOOLS REQUIRED:

DRILLS: 3/8"

WRENCHES: 9/16, 11/16", 3/4"

2,000 LB GROSS TRAILER WEIGHT, 200 LB TONGUE WEIGHT. WARNING: CONSULT VEHICLE OWNERS MANUAL FOR TOWING RECOMMENDATIONS AND LIMITATIONS. THIS PRODUCT IS DESIGNED FOR TRAILER TOWING ONLY AND SHOULD NOT BE USED FOR ANY OTHER PURPOSE.

WARNING: USE ONLY RIGID HITCH APPROVED AND MANUFACTURED DRAW BAR INSERT OR WARRANTY WILL BE VOID

NOTE: INSTALL PARTS LOOSELY UNTIL ALL ATTACHMENTS HAVE BEEN MADE TO VEHICLE

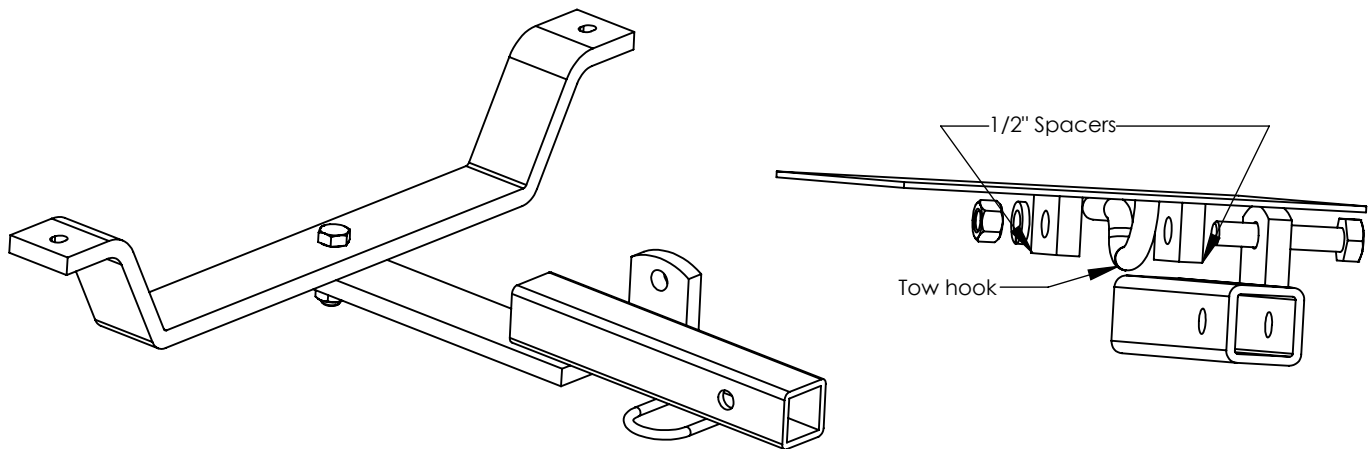

Figure 1-1

1. Remove spare tire from tire well of the trunk. If equipped, remove the plastic liner as well.
2. Remove all mounting bolts from the hitch, noting the proper location of each.
3. Loosely mount the tab welded to the hitch receiver tube to the passenger side of the tow hook located in the center of the vehicle on the bottom of the spare tire well. Place a 1/2" thick spacer provided between the hitch tab and the tow hook to center the hitch on the vehicle. Use the other 1/2" spacer as reinforcement on the opposite side of the tow hook (see Figure 1-1).
4. Loosely attach the front cross bar of the hitch to the main bar using the 1/2 x 1-3/4" hex bolt provided. The cross bar should be placed on top of the main bar with the bolt facing down (see the illustration above).

Note: Before drilling position hitch as far rearward as possible to ensure that front cross bar sits flat on trunk pan just rearward of reinforcement strap welded to bottom of spare tire well.

5. Center the hitch on the spare tire well and use it as a template to drill the two 3/8" mounting holes required.
6. Insert the 3/8 x 1-1/2" bolts with large fender washers down through the holes drilled in the tire well and attach the hitch cross bar using the conical washers and nuts provided.
7. Tighten all fasteners and replace liner and spare tire removed in step 1.

TIGHTEN ALL FASTENERS TO THE TORQUE SPECIFICATIONS SHOWN BELOW

Hardware Package:	(1) 1/2 x 1-3/4" Hex bolt	(2) 1/2 x 1-1/4 x 2" Spacer blocks	(2) 3/8" Heavy hex nuts
	(1) 1/2 x 2-3/4" Hex bolt	(2) 3/8 x 1-1/2" Hex bolts	(1) UB-6001 Draw bar kit
	(2) 1/2" Lock washers	(2) 3/8" Fender washers	
	(2) 1/2"-13 Hex nuts	(2) 3/8" Conical washers	

GIVE THIS INSTRUCTION SHEET TO VEHICLE OWNER

BOLT TIGHTENING TORQUE (LB-FT)			
BOLT SIZE	TORQUE	BOLT SIZE	TORQUE
3/8"	25 LB FT	8MM	20 LB FT
7/16"	50 LB FT	10MM	38 LB FT
1/2"	60 LB FT	12MM	68 LB FT
3/4"	120 LB FT		

THIS PRODUCT COMPLIES WITH SAFETY SPECIFICATIONS AND REQUIREMENTS FOR SAE AND VESC REGULATION V-5 FOR CONNECTING DEVICES AND TOWING SYSTEMS. DO NOT MODIFY THIS PRODUCT. INSTALL ONLY ON SPECIFIED VEHICLES IN GOOD CONDITION.

RIGID[®]
HITCH INCORPORATED
 3301 WEST BURNSVILLE PARKWAY
 BURNSVILLE, MN 55337

REV.
1/07